



AC 100/4 (L)
100t capacity class
All terrain crane
Datasheet
metric

MENU GŁÓWNE

AC 100/4 (L)

Tier 4 / Euromot 4



WORKS FOR YOU.™

Page · Seite · Page · Pagina · Página · Página · Страница:

Dimensions · Abmessungen · Encombremet · Dimensioni · Dimensiones · Dimensões · Размеры	5
Specifications · Technische Daten · Caractéristiques · Dati tecnici · Datos técnicos · Especificações · Технические характеристики	6
Equipment · Einrichtungen · Équipement · Equipaggiamento · Equipamiento · Equipamento · Оборудование	7
Counterweight · Contrepoids · Gegengewicht · Contrappeso · Contrapeso · Contrapeso · Противовес	8

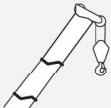

HA (HA50, HA60)

Main boom · Hauptausleger · Flèche principale · Braccio base · Pluma principal · Lança principal · Главная стрела	9
--	---



HAV (HA50, HA60)

Folding swing-away jib · Klappspitze · Fléchette pliante · Punta retrattile · Plumín de articulación · Jib articulada desdoblável · Складная убирающаяся дополнительная стрела	18
--	----



HAV-VA (HA50, HA60)

Variable extension with swing-away jib · Variable Verlängerung mit Klappspitze · Rallonge variable à fléchette pliante · Prolungamento variabile con punta retrattile · Extensión variable con plumín articulado · Extensão variável com braço extensor articulado · Удлинитель переменной длины с откидной дополнительной стрелой	32
---	----

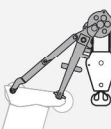

MS (HA50, HA60)

Runner · Montagespitze · Potence · Runner · Runner · Ponta de montagem (Runner) · Шкив	44
---	----

Technical description · Technische Beschreibung · Descriptif technique · Descrizione tecnica · Descripción técnica · Descrição técnica · Техническое описание	52
--	----

Zeichenerklärung · Légende · Leggenda · Leyenda · Legenda · Условные Обозначения

	Counterweight · Contrepoids · Gegengewicht · Contrappeso · Contrapeso · Contrapeso · Противовес
	Lifting capacities on outriggers · Tragfähigkeiten, abgestützt · Capacités de levage sur stabilisateurs · Portate su stabilizzatori · Capacidad de elevación sobre apoyos · Capacidades de içamento sobre estabilizadores · Грузоподъемность с выдвинутыми опорами · 360°
	Radius · Portée · Ausladung · Raggio di lavoro · Radio de trabajo · Raio de operação · Рабочий радиус
	Main boom · Flèche principale · Hauptausleger · Braccio principale · Pluma principal · Lança principal · Главная стрела
	Swing-away jib · Klappspitze · Fléchette pliante · Punta retráctil · Plumín de articulación · Jib articulada desdobrável · Складная убирающаяся дополнительная стрела
	Runner · Montagespitze · Potence · Runner · Runner · Ponta de montagem (Runner) · Шкив
	Adapter · Adapter · Adaptateur · Adattatore · Aadaptador · Adaptador · Переходник
	Max. axle loads · Max. Achslasten · Poids d'essieu max. · Pesi sugli assi max. · Carga por eje máx. · Carga máxima por eixo · Максимальная нагрузка на ось
	Mechanism · Antrieb · Mécanisme · Funzioni · Mecanismos · Mecanismo · Механизм
	Tires · Bereifung · Pneumatiques · Pneumatici · Neumáticos · Pneus · Шины
	Hook block · Unterflasche · Crochet-moufle · Bozzello · Gancho · Moitão · Крюкблок
	Hoist · Hubwerk · Treuil de levage · Agano · Cabrestante · Guincho · подъем
	Dolly · Nachläufer · Remorque · Vagoni · Tráiler · Plataforma · Грузовая тележка
	Travel speed · Fahrgeschwindigkeit · Vitesse sur route · Velocità su strada · Velocidad en carretera · Velocidade em estrada · Скорость движения
	Gradeability – road · Steigfähigkeit – Straße · Capacité sur rampes – route · Pendenza superabile – su strada · Pendenza franqueable – carretera · Capacidade de rampa – rodovia · Способность преодолевать подъемы – дорога
	Gradeability – off road · Steigfähigkeit – Gelände · Capacité sur rampes – tous terrains · Pendenza superabile – fuoristrada · Pendenza franqueable – campo a través · Capacidade de rampa – fora da estrada · Способность преодолевать подъемы – бездорожье
	Slewing · Drehwerk · Orientation · Rotazione · Unidad de giro · Giro · Поворот
	Boom telescoping · Teleskopieren · Télescopage · Funzione telescopica · Despliegue telescópico · Telescópica · Выдвижение/втягивание стрелы
	Boom elevation · Ausleger-Winkelstellung · Relevage de flèche · Angolazione braccio · Elevación de pluma · Elevação da lança · Угол подъема стрелы

	Working speeds · Arbeitsgeschwindigkeiten · Vitesses opérationnelles · Velocità di lavoro · Velocidades de trabajo · Velocidades de trabalho · Рабочие скорости
	Max. line pull · Max. Seilzug · Traction par câble max. · Tiro max · Tensión máx. de cable · Tração máx. por cabo · Максимальная грузоподъемность троса
	Rope diameter · Seildurchmesser · Diamètre du câble · Diametro della fune · Diámetro cable · Diámetro do cabo · Диаметр троса
	Rope length · Seillänge · Longueur de câble · Lunghezza fune · Longitud cable · Compr. cabo · Длина троса
	Hook block (capacity-sheaves-rope diameter) · Unterflasche (Tragfähigkeit-Rollen-Seildurchmesser) · Crochet-moufle (capacité de charge-poulies-diamètre du câble) · Bozzello (portata-pulegge-diametro fune) · Gancho (capacidad de carga-poleas-diametro de cable) · Moitão (capacidade-poliás-diâmetro dos cabos) · Крюкблок (грузоподъемность-шкивы-диаметр троса)
	Number of lines · Einscherung · Nombre de brins · No max avvolgim. · Reenvios máx. · Número de cabos · Кратность троса
	Possible load of hook block · Mögliche Traglast Unterflasche · Charge possible de crochet-moufle · Portata possibile di bozzello · Carga permitida de gancho · Carga possível do moitão · Допустимая нагрузка на крюкблок
	Weight of hook block · Gewicht Unterflasche · Poids de crochet-moufle · Peso di bozzello · Peso de gancho · Peso do moitão · Вес крюкблока
	Distance head sheave axle – hook ground · Abstand Kopfrollenachse – Hakengrund · Distance entre l'axe de la poulie de tête et le fond du crochet · Distanza asse puleggia da testa – zona di ancoraggio del gancio · Distancia eje de la polea de cabeza – fondo del gancho · Distância entre o eixo da polia da cabeça e o fundo do gancho · Расстояние от оси шкива вершины до низа крюка
	Number of sheaves in boom head · Anzahl der Rollen im Auslegerkopf · Nombre de poulies au niveau de la tête de flèche · Numero di pulegge nella testa del braccio · Total de poleas en el cabezal de flecha · Número de poliás na cabeça da lança · Количество шкивов вершины стрелы
	Supporting force · Stützkraft · Force de calage · Carico degli stabilizzatori · Fuerza de apoyo · Força de sustentação · Опорное усилие
	Length of stroke (support cylinders) · Stützhub · Longueur d'appui · Lunghezza corsa (cilindri di stabilizzazione) · Longitud de carrera (cilindros de soporte) · Distância de curso (cilindros de apoio) · Длина хода (цилиндры опор)
	Additional parts for hydraulic system · Zusätzliche Teile für Hydrauliksystem · Composants additionnels pour système hydraulique · Componenti aggiuntivi per impianto idraulico · Peças adicionais para el sistema hidráulico · Дополнительные элементы гидравлической системы

- ▶ Highest lifting capacities of any four-axle crane – both with maximum counterweight configuration as well as when remaining inside the 12-tonne axle load limit
 - ▶ Only four-axle crane in the category above 70 tonnes with a vehicle width of only 2.55 m when using 16.00R25-size tyres
 - ▶ 4.5 t counterweight within 12 t axle load, 20.2 t within 16,5 t axle load roadable
 - ▶ High and economic road and crane performance due to powerful and modern drive train technology
 - ▶ Variable main boom extension system
- ▶ Stärkste Tragfähigkeiten auf 4 Achsen, sowohl bei max. Gegengewicht als auch innerhalb 12 t Achslast
 - ▶ Einziger 4-Achser oberhalb 70 t-Klasse mit einer Fahrzeugbreite von nur 2,55 m mit Bereifung 16.00R25
 - ▶ 4,5 t Gegengewicht innerhalb 12 t Achslast, 20,2 t innerhalb 16,5 t Achslast verfahrbar
 - ▶ Hohe und wirtschaftliche Fahrleistungen und Kranbetrieb durch modernste und leistungsstarke Antriebstechnologie
 - ▶ Variables System zur Hauptauslegerverlängerung
- ▶ Capacités exceptionnelles sur 4 essieux, aussi bien en configuration de contrepoids max. que dans le respect de la charge d'essieu de 12 t
 - ▶ Seule grue 4 essieux dans la catégorie des plus de 70 t, avec une largeur de châssis de seulement 2,55 m, avec des pneumatiques 16.00R25
 - ▶ Déplacement avec contrepoids de 4,5 t avec un poids sur essieu jusqu'à 12 t et de 20,2 t avec un poids sur essieu jusqu'à 16,5 t
 - ▶ Performances élevées et économiques et fonctionnement de la grue via une technologie d'entraînement ultra moderne et ultra puissante
 - ▶ Système variable d'extension de flèche principale
- ▶ Portate più elevate ottenibili con un 4 assi, sia con la massima configurazione di contrappesi che entro il carico massimo di 12 t per asse
 - ▶ La sola gru a 4 assi nella categoria oltre le 70 t con una larghezza del veicolo di soli 2,55 m e pneumatici 16.00R25
 - ▶ 4,5 t contrappeso entro 12 t di carico assiale, 20,2 t entro 16,5 t di carico assiale
 - ▶ Prestazioni convenienti e di alto livello; gru operante grazie alla tecnologia di trasmissione più moderna e ad alto rendimento
 - ▶ Prolunga del braccio base regolabile
- ▶ La grúa de 4 ejes con capacidades de carga más elevadas, tanto para contrapeso máx. así como para carga sobre eje 12 t
 - ▶ La única grúa de 4 ejes por encima de la clase 70 t con una anchura de vehículo de 2,55 m y neumáticos 16.00R25
 - ▶ Contrapeso transportable de 4,5 t sin superar carga sobre eje 12 t, y 20,2 t sin superar carga sobre eje 16,5 t
 - ▶ Elevados rendimientos de conducción y manejo de grúa con bajo consumo, gracias a su transmisión con tecnología de vanguardia y alta potencia
 - ▶ Sistema de extensión variable de pluma principal
- ▶ As mais altas capacidades de elevação de qualquer grua de quatro eixos – tanto na configuração de máximo contrapeso quanto permanecendo no limite de carga de 12 toneladas por eixo
 - ▶ Única grua sobre quatro eixos da categoria acima de 70 toneladas com largura do veículo de apenas 2,55 m usando pneus 16.00R25
 - ▶ Contrapeso de 4,5 t para carga trafegável por eixo até 12 t, 20,2 t para carga por eixo até 16,5 t
 - ▶ Economia e alto desempenho do veículo e da grua graças à poderosa e avançada tecnologia do trem de força
 - ▶ Sistema de extensão variável da lança principal
- ▶ Самая большая грузоподъемность из всех 4-осных кранов, как с максимальным комплектом противовесов, так и в пределах лимита 12-тонной нагрузки на мост
 - ▶ Единственный кран грузоподъемностью выше 70 т, имеющий длину двигателя всего 2,55 м при использовании шин размера 16.00R25
 - ▶ Противовес 4,5 т при нагрузке на мост в пределах 12 т, 20,2 т при нагрузке на мост в пределах 16,5 т при передвижении по дороге
 - ▶ Высокая мощность и экономичность при переездах и при работе крана благодаря мощной и современной трансмиссии
 - ▶ Система удлинителя основной стрелы переменной длины

DIMENSIONS

AC 100/4(L)

Abmessungen · Encombrement · Dimensioni · Dimensiones ·
Dimensões · Размеры

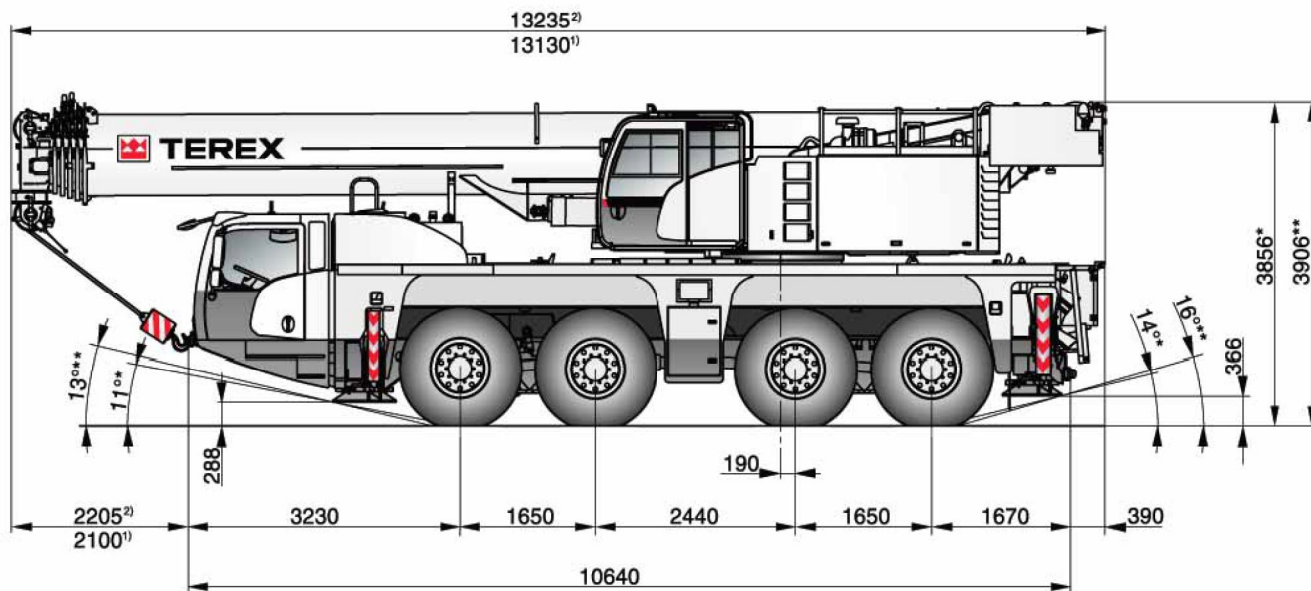

1) 50,0 m 2) 59,4 m



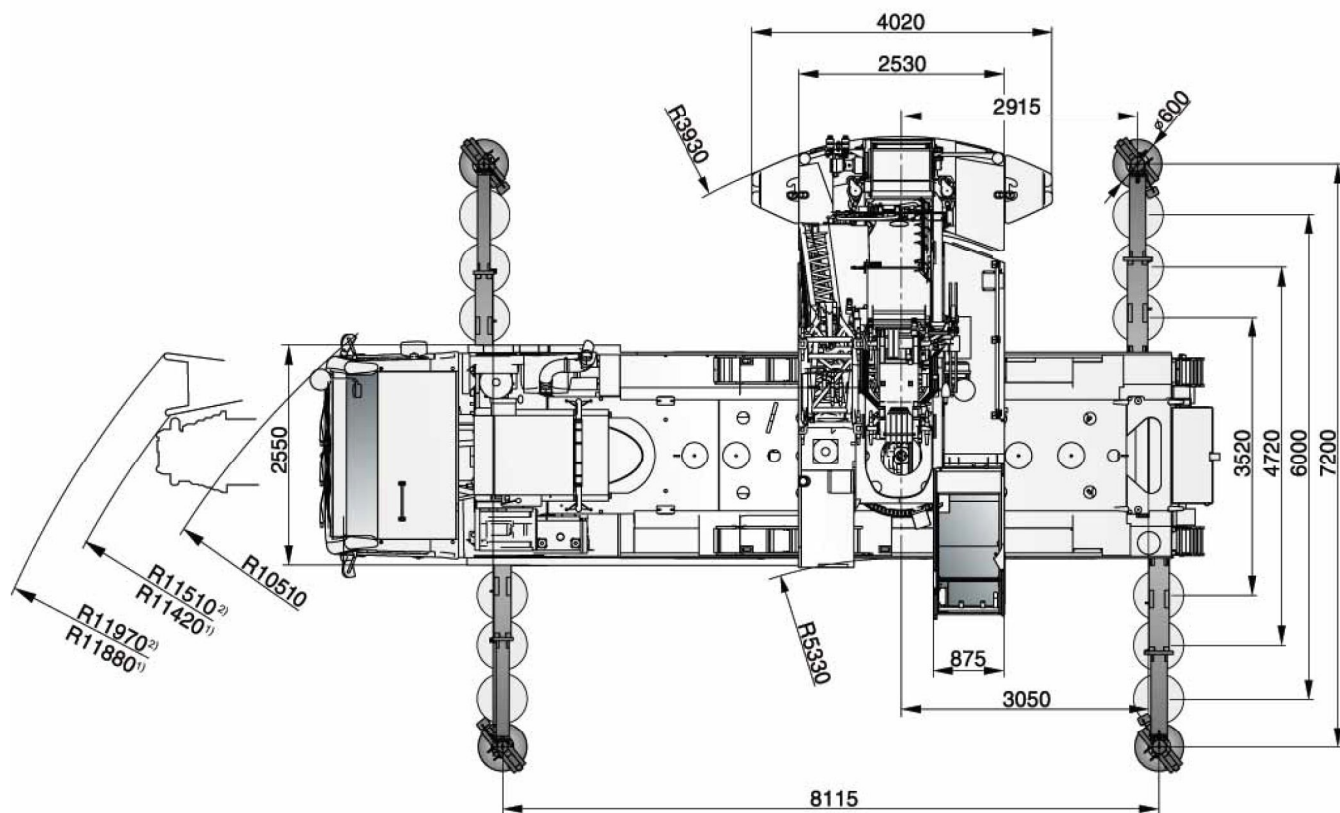



* Wheels · Räder · Roues · Ruote · Ruedas · Rodas · Колеса 14"
** Wheels · Räder · Roues · Ruote · Ruedas · Rodas · Колеса 16"

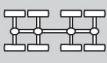

SPECIFICATIONS

AC 100/4(L)



Technische Daten · Caractéristiques · Dati tecnici ·
Datos técnicos · Especificações · Технические характеристики

		Total						HA50	HA60	
< 10,0 t	on request · auf Anfrage · sur demande · su richiesta · bajo demanda · a pedido · по заявке									
12,0 t	48,0 t	8 x 6 x 8	385/95R25	20-1-18	6,1 t	–	X	–	–	X
12,0 t	48,0 t	8 x 6 x 8	445/95R25	–	4,5 t	10,0 m	X	–	–	–
12,0 t	48,0 t	8 x 8 x 8	445/95R25	50-3-18	4,5 t	–	X	–	–	–
14,5 t	54,0 t	8 x 8 x 8	445/95R25	50-3-18	9,0 t	19,0 m	X	–	–	–
16,5 t	65,0 t	8 x 8 x 8	445/95R25	50-3-18	20,2 t	19,0 m	X	–	–	–
12,0 t	48,0 t	8 x 8 x 8	385/95R25	20-1-18	4,5 t	–	–	X	–	–
12,0 t	48,0 t	8 x 8 x 8	445/95R25	8-0-18	4,5 t	–	–	X	–	–
14,5 t	55,0 t	8 x 8 x 8	445/95R25	50-3-18	9,0 t	19,0 m	–	X	–	–
16,5 t	66,0 t	8 x 8 x 8	445/95R25	20-1-18	20,2 t	19,0 m	–	X	–	–









Further configurations on request · Weitere Verfahrzustände auf Anfrage · Autres configurations sur demande · Altre configurazioni su richiesta · Otras configuraciones a petición · Outras configurações a pedido · Другие варианты комплектации предоставляются по запросу







-  1 Highway > 45 km/h · Landstraße > 45 km/h · Route > 45 km/h · Strade extraurbane > 45 km/h · Carretera > 45 km/h · Rodovia > 45 km/h · Дорога > 45 км/ч
-  2 City < 45 km/h · Stadt < 45 km/h · Ville < 45 km/h · Città < 45 km/h · Ciudad < 45 km/h · Urbano < 45 km/h · Город < 45 км/ч
-  3* Minimum turning radius < 5 km/h · Minimaler Kurvenradius < 5 km/h · Rayon de courbure minimum < 5 km/h · Raggio minimo di sterzata < 5 km/h · Radio mínimo de giro < 5 km/h · Raio mínimo de giro < 5 km/h · Минимальный радиус поворота < 5 км/ч
-  4* Off-wall · Wand-weg · Hors mur · Marcia laterale · Desempotrado · Longe da parede · от стены
-  5* Crab steer mode · Hundegang · Marche en crabe · Marcia a granchio · Marcha cangrejo · Modo de translação lateral · Режим поворота на всех колесах «крабовый ход»
-  6* All wheel steering · Allradlenkung · Transmission intégrale · Sterzata integrale · Dirección en todas las ruedas · Todas as rodas exteriorantes · Рулевое управление со всеми управляемыми колесами







* must be activated · muss angewählt werden · activation nécessaire · deve essere attivato · debe activarse · precisa ser ativado · должно быть активировано

			
43 t	61 t	max. 85 km/h ¹⁾	
560 mm	630 mm		

¹⁾ Depending on tire type, size and country specific legislation · Abhängig von Reifentyp, Reifengröße sowie länderspezifischer Gesetzgebung · En fonction du type et de la taille de pneus ainsi que de la législation locale · In base al tipo e alla dimensione dei pneumatici, nonché alle normative locali applicabili · Según tipo de neumático, tamaño y legislación del país · Dependendo do tipo e tamanho do pneu e da legislação específica do país · Зависит от типа шин, размера и требований законодательства страны

					
1	115 m ³ /min	67 kN	18 mm	265 m	
2	115 m ³ /min	67 kN	18 mm	265 m	
	1,4 min ⁻¹				
	ca. 490 s (11.9-50.0m)				
	ca. 590 s (12.0-59.4m)				
	60 s (0°-82°)				

					
1	6,8	8-0-18	5	170	1,00 m
2	13,4	20-1-18	5	300	1,80 m
3	20,0	20-1-18	5	300	1,80 m
4	26,6	50-3-18	5	550	1,80 m
5	33,1	50-3-18	5	550	1,80 m
6	39,5	50-3-18	5	550	1,80 m
7	45,9	50-3-18	5	550	1,80 m
8	52,1	80-5-18	5	650	2,00 m
9	58,4	80-5-18	5	650	2,00 m
10	64,5	80-5-18	5	650	2,00 m
11	70,6	80-5-18	5+S1	650	2,00 m
12	76,7	100-7-18	5+S1	750	2,00 m
13	80,0	100-7-18	5+S1	750	2,00 m

				
		385/95 R 25 14.00 R 25	445/95 R 25 16.00 R 25	525/80 R 25 20.50 R 25
		45 %	40 %	40 %
		> 70 %	> 60 %	> 60 %

EQUIPMENT

AC 100/4(L)

Einrichtungen · Équippement · Equipaggiamento · Equipamiento · Equipamento · Оборудование

HAV / HAV-VA

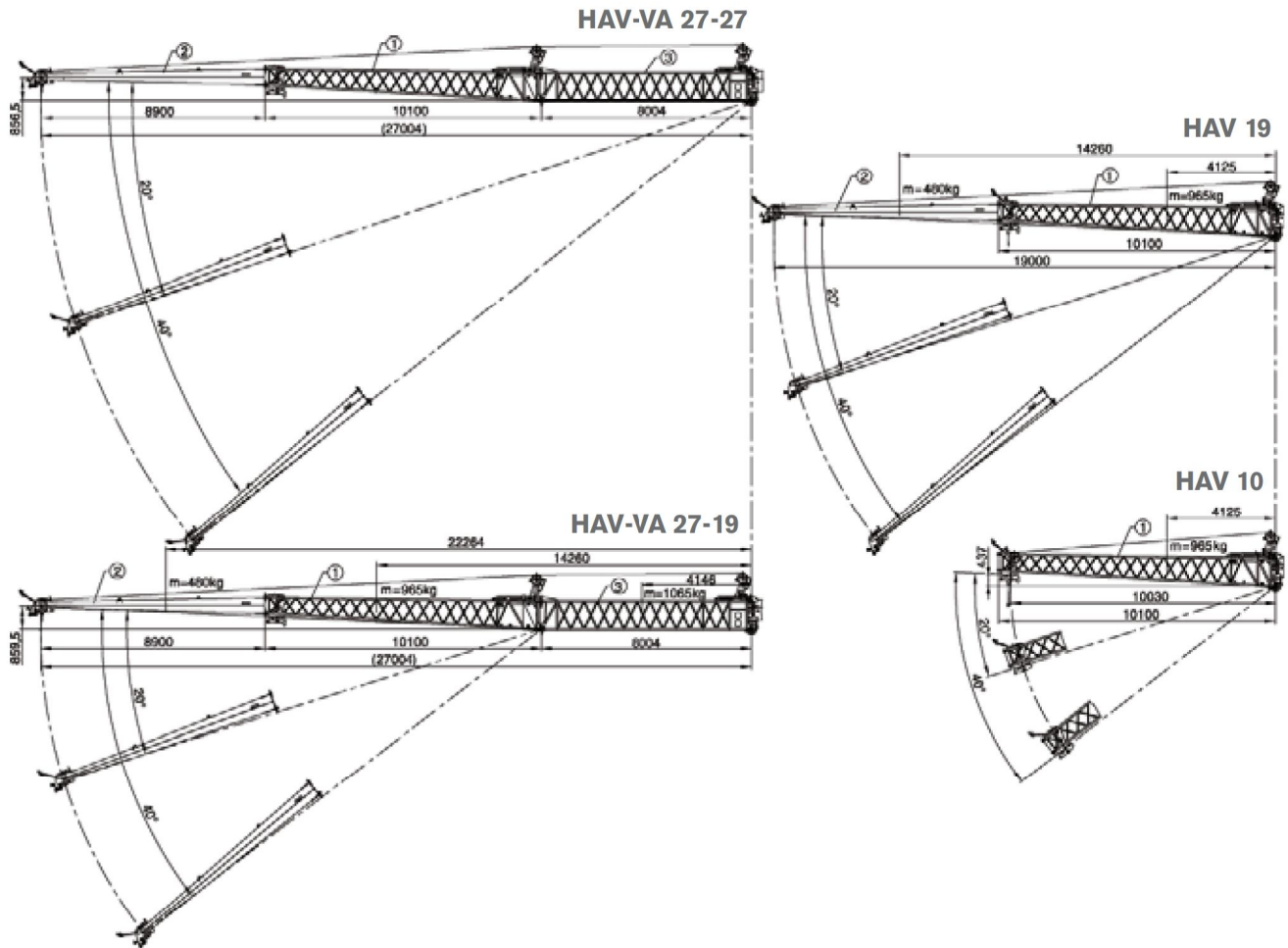

MS

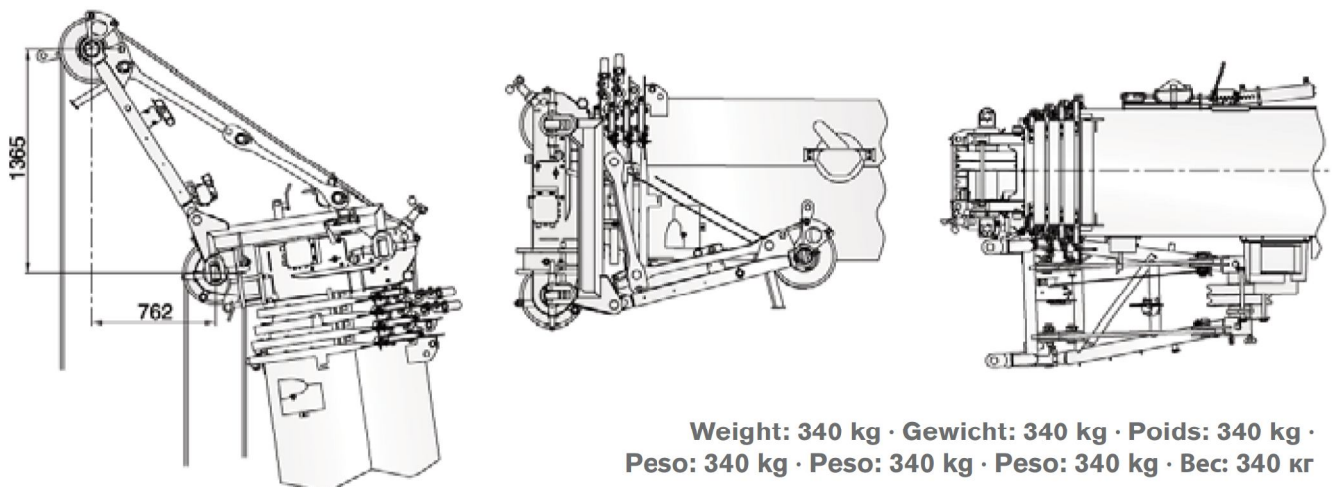

Weight: 340 kg · Gewicht: 340 kg · Poids: 340 kg ·
Peso: 340 kg · Peso: 340 kg · Peso: 340 kg · Bec: 340 кг

COUNTERWEIGHT

AC 100/4(L)

Contrepoids · Gegengewicht · Contrappeso · Contrapeso ·
Contrapeso · Противовес

Parts · Teile · Pièces · Pezzi · Piezas · Peças · Детали

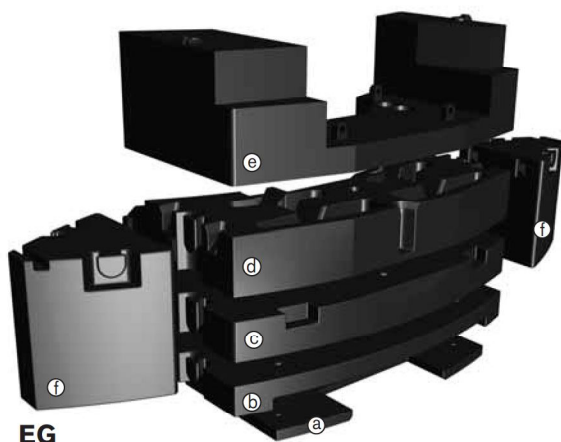

EG

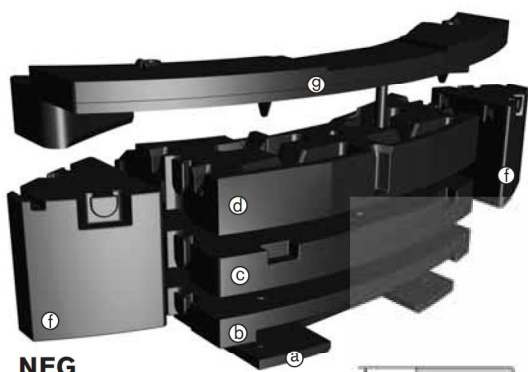

NEG

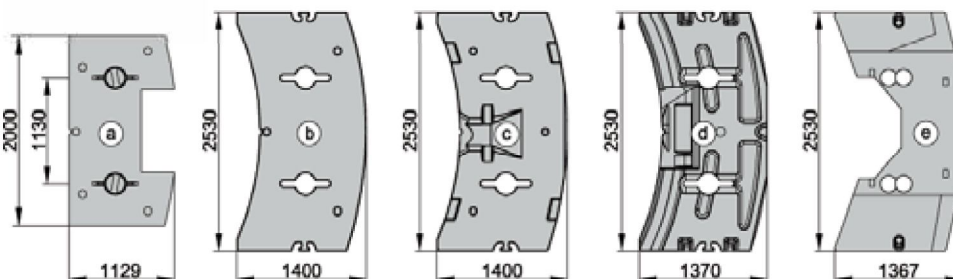
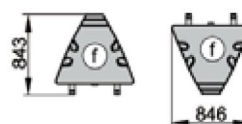
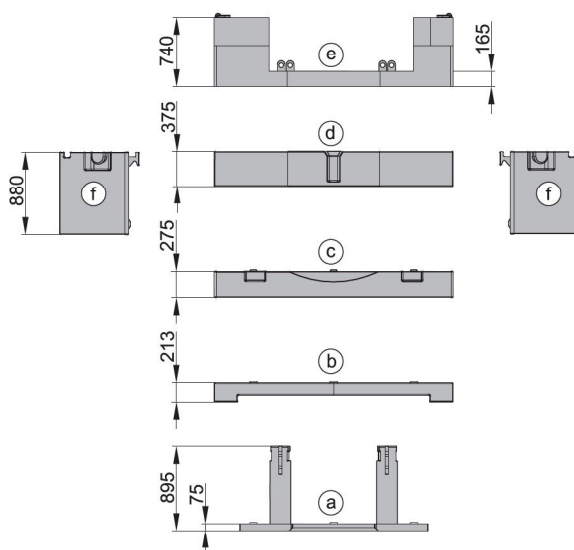



Configurations ·

Konfigurationen · Configurations · Configurazioni · Configuraciones · Configurações · Варианты конфигурации

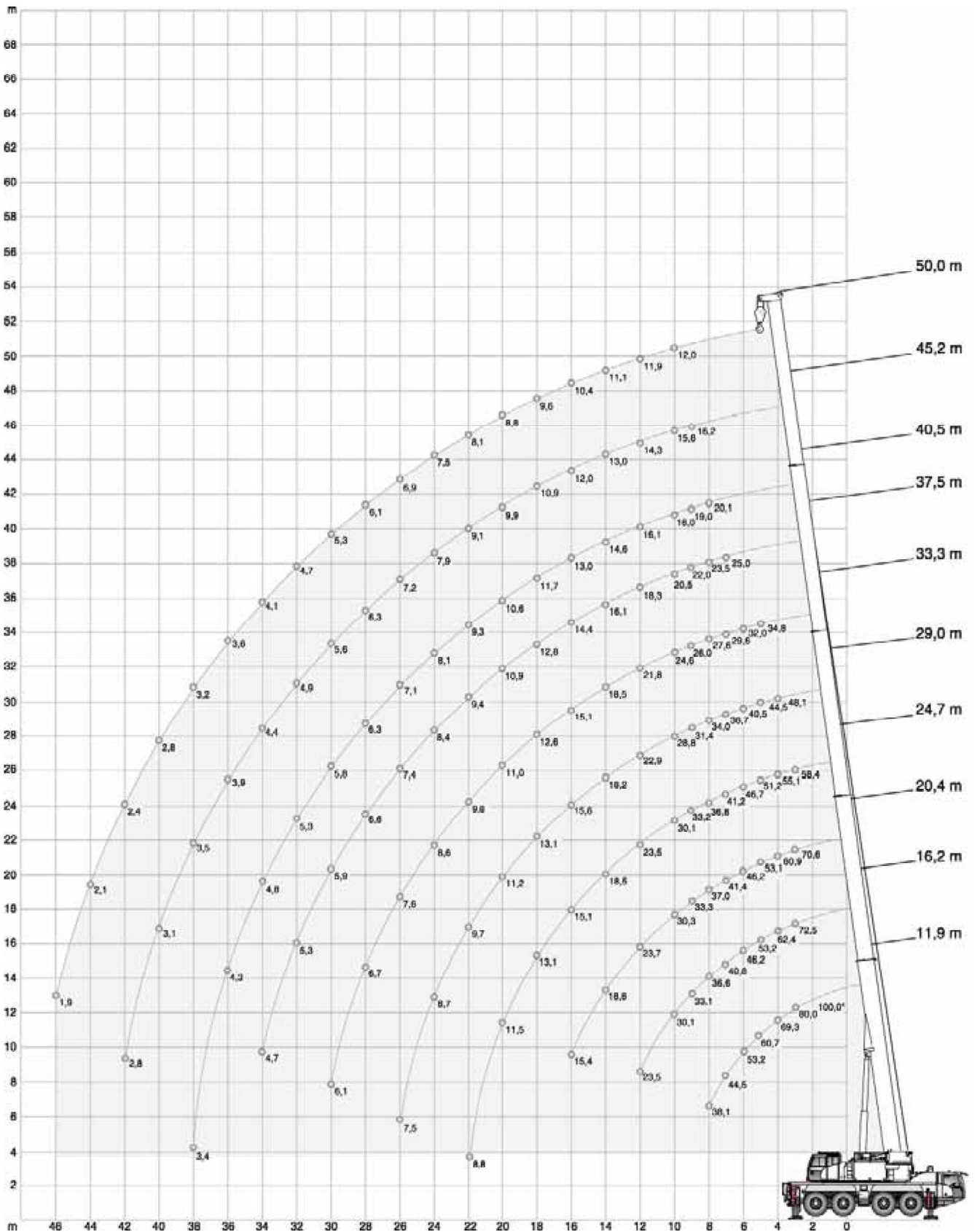
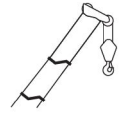

		Ⓐ 1,6 t	Ⓑ 2,9 t	Ⓒ 5,2 t	Ⓓ 6,0 t	Ⓔ 4,5 t	Ⓣ 2,5 t	Ⓣ 2,5 t	Ⓢ 4,7 t
EG	4,5 t					X			
	6,1 t	X				X			
	9,0 t	X	X			X			
	14,2 t	X	X	X		X			
	20,2 t	X	X	X	X	X			
	25,2 t	X	X	X	X	X	X	X	
NEG	0 t								
	1,6 t	X							
	4,5 t	X	X						
	9,7 t	X	X	X					
	15,7 t	X	X	X	X				
	20,7 t	X	X	X	X		X	X	
25,4 t	X	X	X	X	X	X	X	X	

















* Capacity class · Tragfähigkeitsklasse · Classe de capacité · Classe di portata · Clase de capacidad · Classe de capacidade · Класс грузоподъемности











25,2 t		8,10 m x 7,20 m											360°		ISO
															
(0°)		11,9m	11,9m	16,2m	20,4m	24,7m	29,0m	33,3m	37,5m	40,5m	45,2m	50,0m			
m	t	t	t	t	t	t	t	t	t	t	t	t	t	m	
	100,0*	-	-	-	-	-	-	-	-	-	-	-	-		
3	80,0	74,0	72,5	70,6	58,4	-	-	-	-	-	-	-	-	3	
4	69,3	61,9	62,4	60,9	55,1	48,1	-	-	-	-	-	-	-	4	
5	60,7	52,7	53,2	53,1	51,2	44,5	34,8	-	-	-	-	-	-	5	
6	53,2	45,7	46,2	46,2	46,7	40,5	32,0	-	-	-	-	-	-	6	
7	44,5	40,2	40,8	41,4	41,2	36,7	29,6	25,0	-	-	-	-	-	7	
8	38,1	35,8	36,6	37,0	36,8	34,0	27,6	23,5	20,1	-	-	-	-	8	
9	25,6	23,8	33,1	33,3	33,2	31,4	26,0	22,0	19,0	16,2	-	-	-	9	
10	-	-	30,1	30,3	30,1	28,8	24,6	20,5	18,0	15,6	12,0	-	-	10	
12	-	-	23,5	23,7	23,5	22,9	21,8	18,3	16,1	14,3	11,9	-	-	12	
14	-	-	-	18,8	18,5	18,2	18,5	16,1	14,6	13,0	11,1	-	-	14	
16	-	-	-	15,4	15,1	15,6	15,1	14,4	13,0	12,0	10,4	-	-	16	
18	-	-	-	9,1	13,1	13,1	12,6	12,8	11,7	10,9	9,6	-	-	18	
20	-	-	-	-	11,5	11,2	11,0	10,9	10,6	9,9	8,8	-	-	20	
22	-	-	-	-	8,8	9,7	9,8	9,4	9,3	9,1	8,1	-	-	22	
24	-	-	-	-	-	8,7	8,6	8,4	8,1	7,9	7,5	-	-	24	
26	-	-	-	-	-	7,5	7,6	7,4	7,1	7,2	6,9	-	-	26	
28	-	-	-	-	-	5,9	6,7	6,6	6,3	6,3	6,1	-	-	28	
30	-	-	-	-	-	-	6,1	5,9	5,8	5,6	5,3	-	-	30	
32	-	-	-	-	-	-	5,5	5,3	5,3	4,9	4,7	-	-	32	
34	-	-	-	-	-	-	-	4,7	4,8	4,4	4,1	-	-	34	
36	-	-	-	-	-	-	-	-	4,3	3,9	3,6	-	-	36	
38	-	-	-	-	-	-	-	-	3,4	3,5	3,2	-	-	38	
40	-	-	-	-	-	-	-	-	-	3,1	2,8	-	-	40	
42	-	-	-	-	-	-	-	-	-	2,8	2,4	-	-	42	
44	-	-	-	-	-	-	-	-	-	-	2,1	-	-	44	
46	-	-	-	-	-	-	-	-	-	-	1,9	-	-	46	









* Capacity class
 Tragfähigkeitsklasse
 Classe de capacité
 Classe di portata
 Clase de capacidad
 Classe de capacidade
 Класс грузоподъемности

20,2 t		8,10 m x 7,20 m										360°		ISO	
															
	11,9m	16,2m	20,4m	24,7m	29,0m	33,3m	37,5m	40,5m	45,2m	50,0m					
m	t	t	t	t	t	t	t	t	t	t	t	m	m		
3	73,7	72,5	70,6	58,4	-	-	-	-	-	-	-	3	3		
4	61,2	61,7	60,9	55,1	48,1	-	-	-	-	-	-	4	4		
5	52,1	52,6	52,6	51,2	44,5	34,8	-	-	-	-	-	5	5		
6	45,2	45,7	46,0	46,2	40,5	32,0	-	-	-	-	-	6	6		
7	39,8	40,3	40,9	40,7	36,7	29,6	25,0	-	-	-	-	7	7		
8	35,4	36,4	36,6	36,4	34,0	27,6	23,5	20,1	-	-	-	8	8		
9	23,8	32,4	32,7	32,5	31,0	26,0	22,0	19,0	16,2	-	-	9	9		
10	-	27,7	28,0	27,8	27,2	24,6	20,5	18,0	15,6	12,0	-	10	10		
12	-	20,8	21,0	20,8	20,4	20,8	18,3	16,1	14,3	11,9	-	12	12		
14	-	-	16,6	16,4	16,9	16,3	15,8	14,6	13,0	11,1	-	14	14		
16	-	-	13,9	14,0	13,8	13,5	13,4	12,7	12,0	10,4	-	16	16		
18	-	-	9,1	11,7	11,5	11,6	11,2	11,1	10,9	9,6	-	18	18		
20	-	-	-	10,0	10,1	9,9	9,8	9,4	9,2	8,8	-	20	20		
22	-	-	-	8,8	8,7	8,5	8,4	8,1	8,1	7,9	-	22	22		
24	-	-	-	-	7,6	7,5	7,3	7,2	7,0	6,8	-	24	24		
26	-	-	-	-	6,8	6,6	6,4	6,5	6,1	5,9	-	26	26		
28	-	-	-	-	5,9	5,9	5,6	5,7	5,3	5,1	-	28	28		
30	-	-	-	-	-	5,2	5,0	5,0	4,6	4,4	-	30	30		
32	-	-	-	-	-	4,7	4,4	4,4	4,1	3,8	-	32	32		
34	-	-	-	-	-	-	3,9	3,9	3,6	3,3	-	34	34		
36	-	-	-	-	-	-	-	3,5	3,1	2,8	-	36	36		
38	-	-	-	-	-	-	-	2,7	2,7	2,4	-	38	38		
40	-	-	-	-	-	-	-	-	2,4	2,1	-	40	40		
42	-	-	-	-	-	-	-	-	2,1	1,8	-	42	42		
44	-	-	-	-	-	-	-	-	-	1,5	-	44	44		
46	-	-	-	-	-	-	-	-	-	1,3	-	46	46		

14,2 t		8,10 m x 7,20 m										360°		ISO	
															
	11,9m	16,2m	20,4m	24,7m	29,0m	33,3m	37,5m	40,5m	45,2m	50,0m					
m	t	t	t	t	t	t	t	t	t	t	t	m	m		
3	72,8	72,5	70,6	58,4	-	-	-	-	-	-	-	3	3		
4	60,5	61,0	60,9	55,1	48,1	-	-	-	-	-	-	4	4		
5	51,5	52,0	51,9	51,2	44,5	34,8	-	-	-	-	-	5	5		
6	44,6	45,2	45,8	45,6	40,5	32,0	-	-	-	-	-	6	6		
7	39,2	39,8	40,4	39,8	36,5	29,6	25,0	-	-	-	-	7	7		
8	33,0	34,6	34,9	33,4	30,8	27,6	23,5	20,1	-	-	-	8	8		
9	23,8	28,3	28,6	28,3	26,5	25,9	22,0	19,0	16,2	-	-	9	9		
10	-	23,7	24,0	23,7	23,1	22,8	20,5	18,0	15,6	12,0	-	10	10		
12	-	17,6	17,9	18,2	18,2	17,6	17,6	16,1	14,3	11,9	-	12	12		
14	-	-	14,5	14,5	14,3	14,4	14,0	13,8	13,0	11,1	-	14	14		
16	-	-	11,8	11,8	11,9	11,7	11,6	11,2	10,9	10,4	-	16	16		
18	-	-	8,8	10,0	9,9	9,8	9,6	9,6	9,3	9,1	-	18	18		
20	-	-	-	8,5	8,4	8,3	8,1	8,2	7,8	7,6	-	20	20		
22	-	-	-	7,3	7,3	7,1	6,9	7,0	6,6	6,4	-	22	22		
24	-	-	-	-	6,4	6,2	5,9	6,0	5,7	5,4	-	24	24		
26	-	-	-	-	5,6	5,4	5,1	5,2	4,8	4,5	-	26	26		
28	-	-	-	-	4,9	4,7	4,4	4,5	4,1	3,8	-	28	28		
30	-	-	-	-	-	4,1	3,8	3,9	3,5	3,2	-	30	30		
32	-	-	-	-	-	3,6	3,3	3,4	3,0	2,7	-	32	32		
34	-	-	-	-	-	-	2,9	2,9	2,5	2,3	-	34	34		
36	-	-	-	-	-	-	-	2,5	2,1	1,9	-	36	36		
38	-	-	-	-	-	-	-	1,8	1,8	1,5	-	38	38		
40	-	-	-	-	-	-	-	-	1,5	1,2	-	40	40		
42	-	-	-	-	-	-	-	-	1,3	0,9	-	42	42		
44	-	-	-	-	-	-	-	-	-	0,7	-	44	44		



9,0 t		8,10 m x 7,20 m										360°	ISO
													
m	t	t	t	t	t	t	t	t	t	t	t	m	
3	72,0	72,5	70,6	58,4	-	-	-	-	-	-	-	3	
4	59,8	60,3	60,2	55,1	48,1	-	-	-	-	-	-	4	
5	50,9	51,4	51,3	51,2	44,5	34,8	-	-	-	-	-	5	
6	44,1	44,6	45,2	42,1	38,2	32,0	-	-	-	-	-	6	
7	36,2	37,9	36,9	34,3	31,3	29,6	25,0	-	-	-	-	7	
8	28,0	29,7	30,1	28,7	26,9	25,7	23,5	20,1	-	-	-	8	
9	22,6	24,1	24,5	24,2	24,0	22,2	20,8	19,0	16,2	-	-	9	
10	-	20,1	20,4	21,1	20,8	19,6	18,8	17,2	15,6	12,0	-	10	
12	-	14,9	15,6	15,7	15,8	15,6	15,3	14,2	13,4	11,9	-	12	
14	-	-	12,2	12,4	12,4	12,2	12,0	11,8	11,3	10,6	-	14	
16	-	-	9,9	10,1	10,0	9,9	9,7	9,8	9,3	8,6	-	16	
18	-	-	8,2	8,3	8,3	8,1	7,9	8,0	7,6	7,1	-	18	
20	-	-	-	6,9	7,0	6,8	6,5	6,6	6,2	5,8	-	20	
22	-	-	-	5,9	5,9	5,7	5,5	5,6	5,2	4,8	-	22	
24	-	-	-	-	5,1	4,9	4,6	4,7	4,3	4,0	-	24	
26	-	-	-	-	4,4	4,1	3,9	3,9	3,5	3,3	-	26	
28	-	-	-	-	3,8	3,5	3,2	3,3	2,9	2,7	-	28	
30	-	-	-	-	-	3,0	2,7	2,8	2,4	2,1	-	30	
32	-	-	-	-	-	2,6	2,3	2,4	2,0	1,7	-	32	
34	-	-	-	-	-	-	1,9	2,0	1,6	1,3	-	34	
36	-	-	-	-	-	-	-	1,7	1,3	1,0	-	36	
38	-	-	-	-	-	-	-	0,9	1,0	-	-	38	
40	-	-	-	-	-	-	-	-	0,7	-	-	40	

6,1 t		8,10 m x 7,20 m										360°	ISO
													
m	t	t	t	t	t	t	t	t	t	t	t	m	
3	71,6	72,1	70,6	58,4	-	-	-	-	-	-	-	3	
4	59,4	59,9	59,8	55,1	48,1	-	-	-	-	-	-	4	
5	50,6	51,1	51,0	49,4	44,0	34,8	-	-	-	-	-	5	
6	42,5	43,4	41,8	38,4	34,7	32,0	-	-	-	-	-	6	
7	32,8	34,8	33,6	31,2	29,1	27,5	25,0	-	-	-	-	7	
8	25,3	27,0	27,4	26,1	25,4	23,3	21,9	20,1	-	-	-	8	
9	20,4	21,9	22,2	22,5	21,8	20,5	19,4	17,7	16,2	-	-	9	
10	-	18,2	19,1	19,2	18,9	18,4	17,3	16,2	15,2	12,0	-	10	
12	-	13,4	14,1	14,2	14,3	14,1	13,7	13,2	12,3	11,5	-	12	
14	-	-	10,9	11,2	11,3	11,0	10,8	10,8	9,9	9,1	-	14	
16	-	-	8,8	8,9	9,0	8,8	8,5	8,6	8,0	7,4	-	16	
18	-	-	7,2	7,3	7,3	7,1	6,9	7,0	6,6	6,0	-	18	
20	-	-	-	6,0	6,1	5,9	5,7	5,7	5,3	4,8	-	20	
22	-	-	-	5,1	5,1	4,9	4,6	4,7	4,3	3,9	-	22	
24	-	-	-	-	4,3	4,1	3,8	3,9	3,5	3,2	-	24	
26	-	-	-	-	3,7	3,4	3,2	3,2	2,8	2,6	-	26	
28	-	-	-	-	3,1	2,9	2,6	2,7	2,3	2,0	-	28	
30	-	-	-	-	-	2,4	2,1	2,2	1,8	1,6	-	30	
32	-	-	-	-	-	2,0	1,8	1,8	1,4	1,2	-	32	
34	-	-	-	-	-	-	1,4	1,5	1,1	0,8	-	34	
36	-	-	-	-	-	-	-	1,2	0,8	-	-	36	

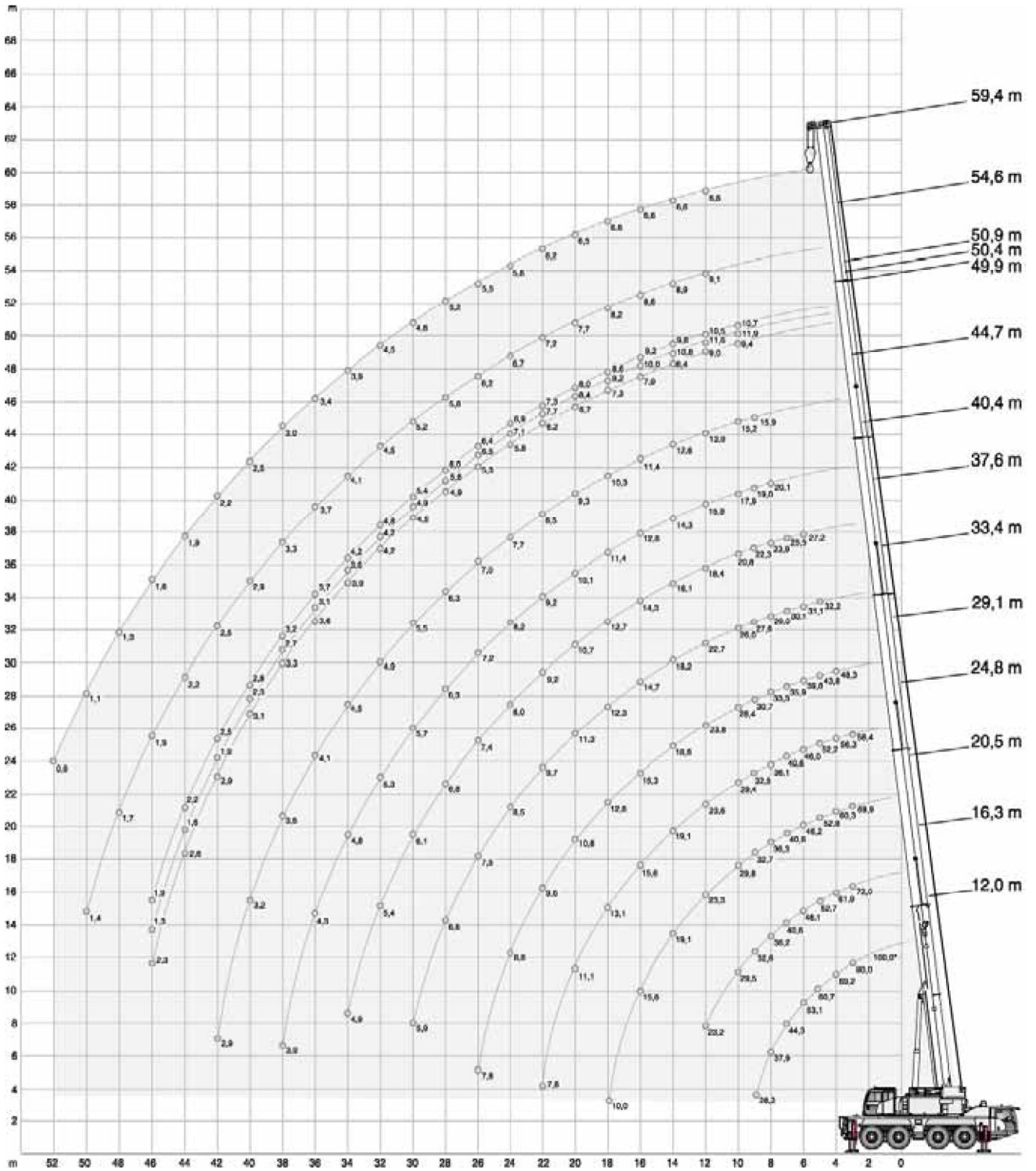
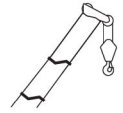

4,5 t		8,10 m x 7,20 m										360°		ISO	
															
		11,9m	16,2m	20,4m	24,7m	29,0m	33,3m	37,5m	40,5m	45,2m	50,0m				
m	t	t	t	t	t	t	t	t	t	t	t	m	t		
3	71,3	71,8	70,6	58,4	-	-	-	-	-	-	-	3	71,3		
4	59,2	59,7	59,6	55,1	48,1	-	-	-	-	-	-	4	59,2		
5	50,4	50,9	50,3	46,8	41,7	34,8	-	-	-	-	-	5	50,4		
6	41,4	42,6	39,7	36,4	32,8	31,4	-	-	-	-	-	6	41,4		
7	30,9	32,8	31,9	29,5	28,5	26,0	23,7	-	-	-	-	7	30,9		
8	23,8	25,4	25,8	25,2	24,0	22,2	21,1	19,2	-	-	-	8	23,8		
9	19,1	20,5	21,5	21,6	20,6	19,8	18,6	17,3	16,2	-	-	9	19,1		
10	-	17,1	17,9	18,1	18,1	17,3	16,3	15,0	14,6	12,0	-	10	-		
12	-	12,5	13,2	13,5	13,5	13,3	12,6	12,4	11,3	10,5	-	12	-		
14	-	-	10,2	10,4	10,4	10,2	9,9	9,9	9,0	8,3	-	14	-		
16	-	-	8,1	8,2	8,3	8,1	7,8	7,9	7,3	6,7	-	16	-		
18	-	-	6,6	6,7	6,7	6,5	6,3	6,4	5,9	5,3	-	18	-		
20	-	-	-	5,5	5,6	5,4	5,1	5,2	4,8	4,2	-	20	-		
22	-	-	-	4,6	4,7	4,4	4,2	4,2	3,8	3,4	-	22	-		
24	-	-	-	-	3,9	3,7	3,4	3,5	3,1	2,7	-	24	-		
26	-	-	-	-	3,3	3,0	2,8	2,8	2,4	2,1	-	26	-		
28	-	-	-	-	2,8	2,5	2,2	2,3	1,9	1,6	-	28	-		
30	-	-	-	-	-	2,1	1,8	1,9	1,5	1,2	-	30	-		
32	-	-	-	-	-	1,7	1,4	1,5	1,1	0,8	-	32	-		
34	-	-	-	-	-	-	1,1	1,2	0,8	-	-	34	-		
36	-	-	-	-	-	-	-	0,9	-	-	-	36	-		





* Capacity class · Tragfähigkeitsklasse · Classe de capacité · Classe di portata · Clase de capacidad · Classe de capacidade · Класс грузоподъемности



25,2 t		8,10 m x 7,20 m														360°		ISO	
  (0°)		12,0m	12,0m	16,3m	20,5m	24,8m	29,1m	33,4m	37,6m	40,4m	44,7m	49,9m	50,4m	50,9m	54,6m	59,4m			
m	t	t	t	t	t	t	t	t	t	t	t	t	t	t	t	t	m	m	
3	100,0*	80,0	73,6	72,0	69,9	58,4	-	-	-	-	-	-	-	-	-	-	3	3	
4		69,2	61,6	61,9	60,3	56,3	48,3	-	-	-	-	-	-	-	-	-	4	4	
5		60,7	52,3	52,7	52,6	52,2	43,8	32,2	-	-	-	-	-	-	-	-	5	5	
6		53,1	45,3	46,1	46,2	46,0	39,8	31,1	27,2	-	-	-	-	-	-	-	6	6	
7		44,3	39,8	40,6	40,8	40,6	35,9	30,1	25,5	-	-	-	-	-	-	-	7	7	
8		37,9	35,4	36,2	36,3	36,1	33,3	29,0	23,9	20,1	-	-	-	-	-	-	8	8	
9		28,2	26,0	32,6	32,7	32,5	30,7	27,6	22,3	19,0	15,9	-	-	-	-	-	9	9	
10		-	-	29,5	29,6	29,4	28,4	26,0	20,8	17,9	15,2	9,4	11,9	10,7	-	-	10	10	
12		-	-	23,2	23,3	23,6	23,8	22,7	18,4	15,9	13,9	9,0	11,6	10,5	9,1	6,6	12	12	
14		-	-	-	19,1	19,1	18,8	18,2	16,1	14,3	12,6	8,4	10,8	9,8	8,9	6,6	14	14	
16		-	-	-	15,6	15,6	15,3	14,7	14,3	12,8	11,4	7,9	10,0	9,2	8,6	6,6	16	16	
18		-	-	-	10,0	13,1	12,8	12,3	12,7	11,4	10,3	7,3	9,2	8,6	8,2	6,6	18	18	
20		-	-	-	-	11,1	10,8	11,3	10,7	10,1	9,3	6,7	8,4	8,0	7,7	6,5	20	20	
22		-	-	-	-	7,8	9,6	9,7	9,2	9,2	8,5	6,2	7,7	7,3	7,2	6,2	22	22	
24		-	-	-	-	-	8,8	8,5	8,0	8,2	7,7	5,8	7,1	6,9	6,7	5,8	24	24	
26		-	-	-	-	-	7,8	7,5	7,4	7,2	7,0	5,3	6,5	6,4	6,2	5,5	26	26	
28		-	-	-	-	-	-	6,6	6,8	6,3	6,3	4,9	5,6	6,0	5,8	5,2	28	28	
30		-	-	-	-	-	-	5,9	6,1	5,7	5,5	4,5	4,9	5,4	5,2	4,8	30	30	
32		-	-	-	-	-	-	3,8	5,4	5,3	4,9	4,2	4,2	4,8	4,5	4,5	32	32	
34		-	-	-	-	-	-	-	4,9	4,8	4,5	3,9	3,6	4,2	4,1	3,9	34	34	
36		-	-	-	-	-	-	-	-	4,3	4,1	3,6	3,1	3,7	3,7	3,4	36	36	
38		-	-	-	-	-	-	-	-	3,9	3,6	3,3	2,7	3,2	3,3	3,0	38	38	
40		-	-	-	-	-	-	-	-	-	3,2	3,1	2,3	2,8	2,9	2,6	40	40	
42		-	-	-	-	-	-	-	-	-	2,9	2,9	1,9	2,5	2,5	2,2	42	42	
44		-	-	-	-	-	-	-	-	-	-	2,6	1,6	2,2	2,2	1,9	44	44	
46		-	-	-	-	-	-	-	-	-	-	2,3	1,3	1,9	1,9	1,6	46	46	
48		-	-	-	-	-	-	-	-	-	-	-	-	-	-	1,7	48	48	
50		-	-	-	-	-	-	-	-	-	-	-	-	-	-	1,4	50	50	
52		-	-	-	-	-	-	-	-	-	-	-	-	-	-	0,9	52	52	



* Capacity class · Tragfähigkeitsklasse · Classe de capacité · Classe di portata · Clase de capacidad · Classe de capacidade · Класс грузоподъемности

20,2 t		8,10 m x 7,20 m														360°		ISO	
 		12,0m	16,3m	20,5m	24,8m	29,1m	33,4m	37,6m	40,4m	44,7m	49,9m	50,4m	50,9m	54,6m	59,4m				
m	t	t	t	t	t	t	t	t	t	t	t	t	t	t	t	m	m		
3	73,4	72,0	69,9	58,4	-	-	-	-	-	-	-	-	-	-	-	3	3		
4	60,9	61,3	60,3	56,3	48,3	-	-	-	-	-	-	-	-	-	-	4	4		
5	51,8	52,2	52,0	52,2	43,8	32,2	-	-	-	-	-	-	-	-	-	5	5		
6	44,9	45,6	45,7	45,5	39,8	31,1	27,2	-	-	-	-	-	-	-	-	6	6		
7	39,4	40,2	40,3	40,1	35,9	30,1	25,5	-	-	-	-	-	-	-	-	7	7		
8	35,0	35,8	35,9	35,7	33,3	29,0	23,9	20,1	-	-	-	-	-	-	-	8	8		
9	26,0	32,0	32,2	32,0	30,4	27,6	22,3	19,0	15,9	-	-	-	-	-	-	9	9		
10	-	27,5	27,7	27,4	28,2	26,0	20,8	17,9	15,2	9,4	11,9	10,7	-	-	-	10	10		
12	-	20,5	21,4	21,4	21,1	20,4	18,4	15,9	13,9	9,0	11,6	10,5	9,1	6,6	12	12	12		
14	-	-	16,9	16,9	16,6	16,0	15,8	14,3	12,6	8,4	10,8	9,8	8,9	6,6	14	14	14		
16	-	-	13,8	13,7	13,4	13,5	13,3	12,4	11,4	7,9	10,0	9,2	8,6	6,6	16	16	16		
18	-	-	9,2	11,4	11,4	11,6	11,1	10,6	10,3	7,3	9,2	8,6	8,2	6,6	18	18	18		
20	-	-	-	9,7	10,1	9,9	9,4	9,5	8,9	6,7	8,4	8,0	7,7	6,5	20	20	20		
22	-	-	-	7,2	8,8	8,5	8,5	8,1	8,1	6,2	7,5	7,3	7,2	6,2	22	22	22		
24	-	-	-	-	7,7	7,3	7,5	7,0	7,0	5,8	6,4	6,9	6,7	5,8	24	24	24		
26	-	-	-	-	6,8	6,7	6,6	6,5	6,1	5,3	5,4	6,0	5,7	5,5	26	26	26		
28	-	-	-	-	-	6,1	5,8	5,8	5,6	4,9	4,6	5,2	5,1	4,9	28	28	28		
30	-	-	-	-	-	5,4	5,2	5,1	4,9	4,5	3,9	4,5	4,5	4,2	30	30	30		
32	-	-	-	-	-	3,8	4,8	4,5	4,3	4,2	3,3	3,9	3,9	3,6	32	32	32		
34	-	-	-	-	-	-	4,3	4,0	3,8	3,8	2,8	3,4	3,4	3,1	34	34	34		
36	-	-	-	-	-	-	-	3,5	3,6	3,3	2,3	2,9	2,9	2,6	36	36	36		
38	-	-	-	-	-	-	-	3,1	3,2	2,9	1,9	2,5	2,5	2,2	38	38	38		
40	-	-	-	-	-	-	-	-	2,8	2,6	1,6	2,1	2,2	1,9	40	40	40		
42	-	-	-	-	-	-	-	-	-	2,2	2,2	1,3	1,8	1,9	42	42	42		
44	-	-	-	-	-	-	-	-	-	-	2,0	1,0	1,5	1,6	44	44	44		
46	-	-	-	-	-	-	-	-	-	-	1,7	0,7	1,3	1,3	46	46	46		
48	-	-	-	-	-	-	-	-	-	-	-	-	-	1,1	48	48	48		
50	-	-	-	-	-	-	-	-	-	-	-	-	-	0,9	50	50	50		



14,2 t		8,10 m x 7,20 m														360°		ISO	
																			
		12,0m	16,3m	20,5m	24,8m	29,1m	33,4m	37,6m	40,4m	44,7m	49,9m	50,4m	50,9m	54,6m	59,4m				
m	t	t	t	t	t	t	t	t	t	t	t	t	t	t	t	m			
3	72,5	72,0	69,9	58,4	-	-	-	-	-	-	-	-	-	-	-	3			
4	60,1	60,5	60,3	56,3	48,3	-	-	-	-	-	-	-	-	-	-	4			
5	51,1	51,5	52,0	51,8	43,8	32,2	-	-	-	-	-	-	-	-	-	5			
6	44,3	45,0	45,1	45,0	39,8	31,1	27,2	-	-	-	-	-	-	-	-	6			
7	38,8	39,7	39,8	39,3	35,9	30,1	25,5	-	-	-	-	-	-	-	-	7			
8	33,1	34,2	34,4	32,9	31,0	29,0	23,9	20,1	-	-	-	-	-	-	-	8			
9	26,0	28,1	28,3	29,0	27,7	25,5	22,3	19,0	15,9	-	-	-	-	-	-	9			
10	-	23,4	24,6	24,5	24,2	22,3	20,8	17,9	15,2	9,4	11,9	10,7	-	-	-	10			
12	-	17,8	18,3	18,3	17,9	17,3	17,1	15,8	13,9	9,0	11,6	10,5	9,1	6,6	-	12			
14	-	-	14,3	14,3	14,0	14,5	13,9	13,3	12,5	8,4	10,8	9,8	8,9	6,6	-	14			
16	-	-	11,6	11,6	12,1	11,7	11,3	11,4	10,7	7,9	10,0	9,2	8,6	6,6	-	16			
18	-	-	7,3	10,0	10,0	9,7	9,9	9,4	9,4	7,3	8,6	8,6	8,2	6,6	-	18			
20	-	-	-	8,6	8,5	8,5	8,4	8,3	7,9	6,7	7,2	7,8	7,4	6,5	-	20			
22	-	-	-	7,2	7,3	7,4	7,2	7,1	6,9	6,2	6,0	6,6	6,3	5,9	-	22			
24	-	-	-	-	6,5	6,4	6,4	6,1	6,0	5,8	4,9	5,6	5,6	5,0	-	24			
26	-	-	-	-	5,8	5,6	5,6	5,3	5,1	5,2	4,1	4,7	4,8	4,2	-	26			
28	-	-	-	-	-	4,9	4,9	4,6	4,7	4,4	3,4	4,0	4,0	3,5	-	28			
30	-	-	-	-	-	4,3	4,2	4,0	4,1	3,8	2,7	3,3	3,4	3,0	-	30			
32	-	-	-	-	-	3,8	3,7	3,7	3,5	3,3	2,2	2,8	2,9	2,5	-	32			
34	-	-	-	-	-	-	3,3	3,3	3,0	2,8	1,8	2,3	2,4	2,1	-	34			
36	-	-	-	-	-	-	-	2,9	2,6	2,4	1,4	1,9	2,0	1,7	-	36			
38	-	-	-	-	-	-	-	2,2	2,3	2,0	1,0	1,6	1,6	1,3	-	38			
40	-	-	-	-	-	-	-	-	2,0	1,7	0,7	1,3	1,3	1,0	-	40			
42	-	-	-	-	-	-	-	-	1,4	1,4	-	1,0	1,0	0,7	-	42			
44	-	-	-	-	-	-	-	-	-	1,2	-	0,7	0,8	-	-	44			
46	-	-	-	-	-	-	-	-	-	1,0	-	-	-	-	-	46			

9,0 t		8,10 m x 7,20 m														360°		ISO	
																			
		12,0m	16,3m	20,5m	24,8m	29,1m	33,4m	37,6m	40,4m	44,7m	49,9m	50,4m	50,9m	54,6m	59,4m				
m	t	t	t	t	t	t	t	t	t	t	t	t	t	t	t	m			
3	71,7	72,0	69,9	58,4	-	-	-	-	-	-	-	-	-	-	-	3			
4	59,5	59,8	59,7	56,3	48,3	-	-	-	-	-	-	-	-	-	-	4			
5	50,5	50,9	51,4	51,2	43,8	32,2	-	-	-	-	-	-	-	-	-	5			
6	43,8	44,5	44,6	41,8	37,7	31,1	27,2	-	-	-	-	-	-	-	-	6			
7	36,4	37,6	36,6	33,8	32,3	29,9	25,5	-	-	-	-	-	-	-	-	7			
8	28,2	29,6	29,8	29,6	27,6	25,3	23,7	20,1	-	-	-	-	-	-	-	8			
9	22,7	24,0	25,1	25,1	23,7	21,7	20,6	19,0	15,9	-	-	-	-	-	-	9			
10	-	20,4	21,0	21,0	20,6	19,5	18,6	16,8	15,2	9,4	11,9	10,7	-	-	-	10			
12	-	15,0	15,5	15,5	15,5	15,7	14,7	13,6	12,8	9,0	11,6	10,5	9,1	6,6	-	12			
14	-	-	12,1	12,3	12,6	12,2	12,0	11,8	11,0	8,4	10,1	9,8	8,9	6,6	-	14			
16	-	-	9,9	10,3	10,1	10,3	10,0	9,9	9,5	7,9	8,2	8,9	8,3	6,6	-	16			
18	-	-	7,3	8,5	8,5	8,5	8,5	8,2	8,0	7,3	6,7	7,4	7,2	6,5	-	18			
20	-	-	-	7,2	7,2	7,1	7,1	6,8	6,6	6,6	5,4	6,1	5,9	5,2	-	20			
22	-	-	-	6,1	6,1	6,0	6,0	5,7	5,8	5,6	4,4	5,0	4,9	4,2	-	22			
24	-	-	-	-	5,3	5,1	5,1	5,1	4,9	4,6	3,5	4,2	4,0	3,4	-	24			
26	-	-	-	-	4,6	4,5	4,3	4,4	4,2	3,9	2,8	3,4	3,4	2,8	-	26			
28	-	-	-	-	-	3,9	3,7	3,8	3,5	3,2	2,2	2,8	2,8	2,2	-	28			
30	-	-	-	-	-	3,3	3,2	3,2	3,0	2,7	1,7	2,3	2,3	1,8	-	30			
32	-	-	-	-	-	2,9	2,7	2,8	2,5	2,2	1,2	1,8	1,9	1,4	-	32			
34	-	-	-	-	-	-	2,3	2,4	2,1	1,8	0,8	1,4	1,5	1,0	-	34			
36	-	-	-	-	-	-	-	2,0	1,8	1,5	-	1,1	1,1	0,7	-	36			
38	-	-	-	-	-	-	-	1,4	1,5	1,2	-	0,8	0,8	-	-	38			
40	-	-	-	-	-	-	-	-	1,2	0,9	-	-	-	-	-	40			

6,1 t		8,10 m x 7,20 m														360°		ISO	
																			
		12,0m	16,3m	20,5m	24,8m	29,1m	33,4m	37,6m	40,4m	44,7m	49,9m	50,4m	50,9m	54,6m	59,4m				
m	t	t	t	t	t	t	t	t	t	t	t	t	t	t	t	m	t	m	t
3	71,3	71,6	69,9	58,4	-	-	-	-	-	-	-	-	-	-	-	3	71,3	71,3	
4	59,1	59,5	59,3	56,3	48,3	-	-	-	-	-	-	-	-	-	-	4	59,1	59,1	
5	50,2	50,6	51,1	49,1	43,6	32,2	-	-	-	-	-	-	-	-	-	5	50,2	50,2	
6	42,5	43,7	41,6	38,1	34,2	31,1	27,2	-	-	-	-	-	-	-	-	6	42,5	42,5	
7	33,2	34,8	33,3	32,3	29,9	27,2	25,3	-	-	-	-	-	-	-	-	7	33,2	33,2	
8	25,5	26,9	28,2	27,0	25,1	22,9	21,6	20,1	-	-	-	-	-	-	-	8	25,5	25,5	
9	20,5	22,3	22,9	22,9	21,5	20,4	19,4	17,4	15,9	-	-	-	-	-	-	9	20,5	20,5	
10	-	18,5	19,1	19,1	18,7	18,1	16,9	15,6	14,5	9,4	11,9	10,7	-	-	-	10	-	-	
12	-	13,6	14,0	14,0	14,6	14,3	13,7	13,0	12,0	9,0	11,0	10,5	9,1	6,6	-	12	-	-	
14	-	-	10,8	11,5	11,4	11,4	11,3	11,0	10,3	8,4	8,7	9,5	8,8	6,6	-	14	-	-	
16	-	-	8,9	9,1	9,3	9,2	9,2	8,9	8,5	7,9	6,9	7,7	7,5	6,6	-	16	-	-	
18	-	-	7,3	7,6	7,6	7,5	7,5	7,2	7,2	6,8	5,6	6,2	6,1	5,3	-	18	-	-	
20	-	-	-	6,3	6,4	6,2	6,2	6,3	6,0	5,6	4,4	5,0	4,9	4,2	-	20	-	-	
22	-	-	-	5,3	5,4	5,4	5,2	5,3	5,0	4,6	3,5	4,1	4,0	3,3	-	22	-	-	
24	-	-	-	-	4,5	4,5	4,3	4,4	4,2	3,9	2,7	3,3	3,2	2,6	-	24	-	-	
26	-	-	-	-	4,0	3,8	3,6	3,7	3,5	3,2	2,1	2,7	2,6	2,0	-	26	-	-	
28	-	-	-	-	-	3,2	3,1	3,2	2,9	2,6	1,6	2,2	2,1	1,5	-	28	-	-	
30	-	-	-	-	-	2,8	2,6	2,7	2,4	2,1	1,1	1,7	1,7	1,1	-	30	-	-	
32	-	-	-	-	-	2,4	2,2	2,2	2,0	1,7	-	1,3	1,3	0,8	-	32	-	-	
34	-	-	-	-	-	-	1,8	1,9	1,6	1,3	-	0,9	0,9	-	-	34	-	-	
36	-	-	-	-	-	-	-	1,6	1,3	1,0	-	-	-	-	-	36	-	-	
38	-	-	-	-	-	-	-	0,9	1,0	0,7	-	-	-	-	-	38	-	-	
40	-	-	-	-	-	-	-	-	0,8	-	-	-	-	-	-	40	-	-	

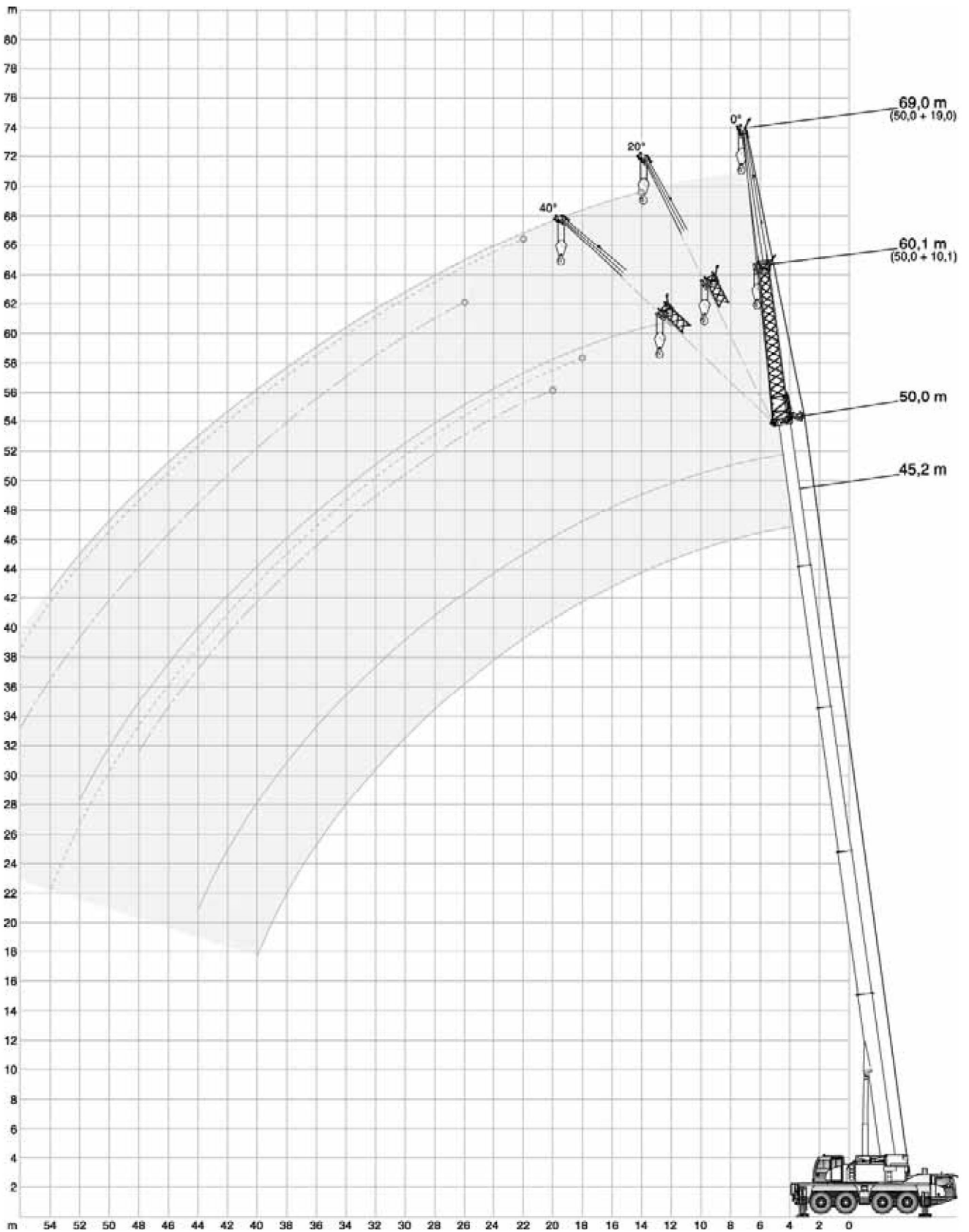
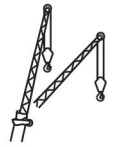
4,5 t		8,10 m x 7,20 m														360°		ISO	
																			
		12,0m	16,3m	20,5m	24,8m	29,1m	33,4m	37,6m	40,4m	44,7m	49,9m	50,4m	50,9m	54,6m	59,4m				
m	t	t	t	t	t	t	t	t	t	t	t	t	t	t	t	m	t	m	t
3	71,0	71,4	69,9	58,4	-	-	-	-	-	-	-	-	-	-	-	3	71,0	71,0	
4	58,9	59,3	59,1	56,3	48,3	-	-	-	-	-	-	-	-	-	-	4	58,9	58,9	
5	50,0	50,6	50,9	46,6	41,3	32,2	-	-	-	-	-	-	-	-	-	5	50,0	50,0	
6	41,5	42,6	39,4	36,0	33,9	31,1	27,2	-	-	-	-	-	-	-	-	6	41,5	41,5	
7	31,2	32,8	31,5	30,6	28,3	25,6	24,0	-	-	-	-	-	-	-	-	7	31,2	31,2	
8	24,0	25,6	26,6	25,6	23,7	22,2	20,3	18,9	-	-	-	-	-	-	-	8	24,0	24,0	
9	19,2	20,9	21,6	21,5	20,3	19,4	18,2	16,7	15,5	-	-	-	-	-	-	9	19,2	19,2	
10	-	17,4	18,0	17,9	17,8	17,5	15,8	15,0	14,0	9,4	11,9	10,7	-	-	-	10	-	-	
12	-	12,7	13,2	13,8	13,7	13,4	13,3	12,1	11,5	9,0	10,1	10,5	9,1	6,6	-	12	-	-	
14	-	-	10,4	10,7	10,6	10,8	10,6	10,1	9,6	8,4	7,9	8,6	8,0	6,6	-	14	-	-	
16	-	-	8,2	8,6	8,6	8,5	8,5	8,2	7,9	7,6	6,2	7,0	6,8	6,0	-	16	-	-	
18	-	-	6,8	7,0	7,0	6,9	6,9	6,9	6,7	6,1	4,9	5,6	5,4	4,6	-	18	-	-	
20	-	-	-	5,8	5,8	5,8	5,7	5,8	5,5	5,0	3,8	4,4	4,3	3,6	-	20	-	-	
22	-	-	-	4,8	4,9	4,9	4,7	4,8	4,5	4,1	2,9	3,5	3,4	2,8	-	22	-	-	
24	-	-	-	-	4,2	4,1	3,9	4,0	3,7	3,4	2,2	2,8	2,7	2,1	-	24	-	-	
26	-	-	-	-	3,6	3,4	3,2	3,3	3,1	2,8	1,6	2,3	2,2	1,6	-	26	-	-	
28	-	-	-	-	-	2,9	2,7	2,8	2,5	2,2	1,2	1,8	1,7	1,1	-	28	-	-	
30	-	-	-	-	-	2,4	2,2	2,3	2,0	1,8	0,7	1,3	1,3	0,7	-	30	-	-	
32	-	-	-	-	-	2,0	1,8	1,9	1,6	1,4	-	0,9	0,9	-	-	32	-	-	
34	-	-	-	-	-	-	1,5	1,6	1,3	1,0	-	-	-	-	-	34	-	-	
36	-	-	-	-	-	-	-	1,3	1,0	0,7	-	-	-	-	-	36	-	-	
38	-	-	-	-	-	-	-	-	0,7	-	-	-	-	-	-	38	-	-	



25,2 t		8,10 m x 7,20 m		360°		ISO	
 50,0 m				 45,2 m			
m	t	10,1 m			19,0 m		
		0°	20°	40°	0°	20°	40°
12	6,7	-	-	-	-	-	-
14	6,7	-	-	3,7	-	-	-
16	6,7	-	-	3,7	-	-	-
18	6,7	6,7	-	3,7	-	-	-
20	6,7	6,4	5,9	3,7	-	-	-
22	6,3	6,1	5,7	3,7	3,7	-	-
24	5,9	5,8	5,4	3,7	3,7	-	-
26	5,6	5,5	5,2	3,7	3,6	3,3	-
28	5,2	5,2	5,0	3,7	3,6	3,2	-
30	4,9	4,9	4,8	3,7	3,5	3,2	-
32	4,5	4,7	4,6	3,6	3,4	3,1	-
34	3,9	4,2	4,4	3,5	3,2	3,0	-
36	3,4	3,7	3,9	3,3	3,1	2,9	-
38	2,9	3,2	3,4	3,1	3,0	2,8	-
40	2,5	2,8	2,9	2,7	2,8	2,7	-
42	2,2	2,4	2,5	2,3	2,7	2,7	-
44	1,9	2,1	2,2	2,0	2,4	2,6	-
46	1,6	1,8	1,8	1,7	2,1	2,3	-
48	1,3	1,5	1,5	1,4	1,8	2,0	-
50	1,1	1,2	-	1,2	1,5	1,7	-
52	0,9	1,0	-	1,0	1,3	1,4	-
54	-	0,8	-	0,8	1,0	1,2	-
56	-	-	-	-	0,8	0,9	-

 41,8 m							
m	t	10,1 m			19,0 m		
		0°	20°	40°	0°	20°	40°
10	10,9	-	-	-	-	-	-
12	10,7	-	-	5,4	-	-	-
14	10,4	9,3	-	5,3	-	-	-
16	10,0	9,0	7,7	5,2	-	-	-
18	9,3	8,7	7,6	5,1	4,7	-	-
20	8,6	8,3	7,4	5,0	4,5	-	-
22	7,9	7,8	7,2	4,8	4,4	-	-
24	7,3	7,2	6,9	4,7	4,2	3,6	-
26	6,7	6,7	6,7	4,6	4,1	3,5	-
28	6,0	6,2	6,3	4,4	4,0	3,5	-
30	5,5	5,5	5,7	4,3	3,9	3,4	-
32	4,8	5,1	5,2	4,2	3,8	3,3	-
34	4,2	4,5	4,7	4,0	3,7	3,3	-
36	3,7	4,0	4,1	3,7	3,6	3,3	-
38	3,3	3,5	3,6	3,5	3,6	3,2	-
40	2,9	3,1	3,2	3,1	3,4	3,2	-
42	2,5	2,7	-	2,7	3,1	3,2	-
44	2,2	2,3	-	2,4	2,7	2,9	-
46	1,9	2,0	-	2,1	2,4	2,5	-
48	1,7	-	-	1,8	2,1	2,2	-
50	-	-	-	1,6	1,8	1,9	-
52	-	-	-	1,4	1,5	-	-
54	-	-	-	1,2	1,3	-	-
56	-	-	-	1,0	-	-	-

 11,9 m							
m	t	10,1 m			19,0 m		
		0°	20°	40°	0°	20°	40°
3	13,4	-	-	9,0	-	-	-
4	13,4	-	-	8,8	-	-	-
5	13,4	13,4	-	8,6	-	-	-
6	13,4	12,8	-	8,5	-	-	-
7	13,3	12,0	-	8,2	-	-	-
8	12,9	11,4	9,5	8,0	-	-	-
9	12,5	10,8	9,1	7,7	-	-	-
10	12,1	10,3	8,7	7,4	6,5	-	-
12	11,0	9,3	8,1	6,9	5,9	-	-
14	9,8	8,5	7,7	6,3	5,5	-	-
16	8,8	7,9	7,5	5,7	5,0	4,3	-
18	7,9	7,5	-	5,3	4,7	4,1	-
20	-	-	-	4,9	4,4	3,9	-
22	-	-	-	4,5	4,1	3,7	-
24	-	-	-	4,2	3,9	3,7	-
26	-	-	-	3,9	3,8	-	-

20,2 t 8,10 m x 7,20 m 360° ISO

50,0 m

m	10,1 m			19,0 m		
	0°	20°	40°	0°	20°	40°
12	6,7	-	-	-	-	-
14	6,7	-	-	3,7	-	-
16	6,7	-	-	3,7	-	-
18	6,7	6,7	-	3,7	-	-
20	6,7	6,4	5,9	3,7	-	-
22	6,3	6,1	5,7	3,7	3,7	-
24	5,9	5,8	5,4	3,7	3,7	-
26	5,6	5,5	5,2	3,7	3,6	3,3
28	4,9	5,2	5,0	3,7	3,6	3,2
30	4,2	4,6	4,8	3,7	3,5	3,2
32	3,6	3,9	4,2	3,6	3,4	3,1
34	3,1	3,4	3,6	3,1	3,2	3,0
36	2,6	2,9	3,1	2,7	3,1	2,9
38	2,2	2,5	2,7	2,3	2,9	2,8
40	1,9	2,1	2,2	2,0	2,5	2,7
42	1,5	1,7	1,9	1,7	2,1	2,4
44	1,2	1,4	1,5	1,4	1,8	2,1
46	1,0	1,2	1,2	1,1	1,5	1,7
48	0,8	0,9	1,0	0,9	1,2	1,4
50	-	-	-	-	1,0	1,2
52	-	-	-	-	0,7	0,9

45,2 m

m	10,1 m			19,0 m		
	0°	20°	40°	0°	20°	40°
12	8,6	-	-	4,6	-	-
14	8,5	-	-	4,6	-	-
16	8,4	8,2	-	4,6	-	-
18	8,2	7,9	7,2	4,6	-	-
20	7,7	7,5	7,1	4,5	4,2	-
22	7,2	7,1	7,0	4,4	4,1	-
24	6,7	6,7	6,7	4,3	4,0	3,5
26	5,7	6,2	6,3	4,2	3,9	3,4
28	5,2	5,3	5,6	4,1	3,8	3,4
30	4,5	4,9	4,9	4,0	3,7	3,3
32	3,9	4,2	4,5	3,8	3,7	3,3
34	3,4	3,7	3,9	3,5	3,6	3,2
36	2,9	3,2	3,4	3,1	3,4	3,2
38	2,5	2,8	2,9	2,7	3,0	3,1
40	2,2	2,4	2,5	2,3	2,7	2,9
42	1,9	2,0	2,1	2,0	2,4	2,7
44	1,6	1,7	1,8	1,7	2,1	2,3
46	1,3	1,4	-	1,4	1,8	2,0
48	1,1	1,2	-	1,2	1,5	1,7
50	0,9	1,0	-	1,0	1,2	1,4
52	-	-	-	0,8	1,0	1,1
54	-	-	-	-	0,8	-

41,8 m

m	10,1 m			19,0 m		
	0°	20°	40°	0°	20°	40°
10	10,9	-	-	-	-	-
12	10,7	-	-	5,4	-	-
14	10,4	9,3	-	5,3	-	-
16	10,0	9,0	7,7	5,2	-	-
18	9,3	8,7	7,6	5,1	4,7	-
20	8,6	8,3	7,4	5,0	4,5	-
22	7,6	7,8	7,2	4,8	4,4	-
24	6,9	7,0	6,9	4,7	4,2	3,6
26	6,0	6,3	6,3	4,6	4,1	3,5
28	5,2	5,6	5,8	4,4	4,0	3,5
30	4,5	4,9	5,1	4,3	3,9	3,4
32	3,9	4,2	4,4	4,0	3,8	3,3
34	3,4	3,7	3,9	3,6	3,7	3,3
36	2,9	3,2	3,3	3,1	3,5	3,3
38	2,5	2,8	2,9	2,7	3,2	3,2
40	2,2	2,4	2,5	2,4	2,8	3,1
42	1,9	2,0	-	2,0	2,4	2,7
44	1,6	1,7	-	1,7	2,1	2,3
46	1,3	1,4	-	1,5	1,8	2,0
48	1,1	-	-	1,2	1,5	1,6
50	-	-	-	1,0	1,2	1,3
52	-	-	-	0,9	1,0	-
54	-	-	-	-	0,8	-

11,9 m

m	10,1 m			19,0 m		
	0°	20°	40°	0°	20°	40°
3	13,4	-	-	9,0	-	-
4	13,4	-	-	8,8	-	-
5	13,4	13,4	-	8,6	-	-
6	13,4	12,8	-	8,5	-	-
7	13,3	12,0	-	8,2	-	-
8	12,9	11,4	9,5	8,0	-	-
9	12,5	10,8	9,1	7,7	-	-
10	12,1	10,3	8,7	7,4	6,5	-
12	11,0	9,3	8,1	6,9	5,9	-
14	9,8	8,5	7,7	6,3	5,5	-
16	8,8	7,9	7,5	5,7	5,0	4,3
18	7,9	7,5	-	5,3	4,7	4,1
20	-	-	-	4,9	4,4	3,9
22	-	-	-	4,5	4,1	3,7
24	-	-	-	4,2	3,9	3,7
26	-	-	-	3,9	3,8	-

14,2 t 8,10 m x 7,20 m 360° ISO

50,0 m

m	10,1 m			19,0 m		
	0°	20°	40°	0°	20°	40°
12	6,7	-	-	-	-	-
14	6,7	-	-	3,7	-	-
16	6,7	-	-	3,7	-	-
18	6,7	6,7	-	3,7	-	-
20	6,7	6,4	5,9	3,7	-	-
22	6,0	6,1	5,7	3,7	3,7	-
24	5,0	5,6	5,4	3,7	3,7	-
26	4,2	4,7	5,2	3,7	3,6	3,3
28	3,6	4,0	4,4	3,4	3,6	3,2
30	3,0	3,4	3,8	2,9	3,5	3,2
32	2,5	2,9	3,1	2,4	3,1	3,1
34	2,0	2,4	2,6	2,0	2,7	3,0
36	1,6	1,9	2,2	1,7	2,2	2,8
38	1,3	1,6	1,8	1,3	1,9	2,4
40	1,0	1,2	1,4	1,1	1,6	2,0
42	0,7	0,9	1,1	0,8	1,3	1,6
44	-	-	0,8	-	1,0	1,3
46	-	-	-	-	0,7	1,0
48	-	-	-	-	-	0,7

45,2 m

m	10,1 m			19,0 m		
	0°	20°	40°	0°	20°	40°
12	8,6	-	-	4,6	-	-
14	8,5	-	-	4,6	-	-
16	8,4	8,2	-	4,6	-	-
18	8,2	7,9	7,2	4,6	-	-
20	7,4	7,5	7,1	4,5	4,2	-
22	6,5	6,8	7,0	4,4	4,1	-
24	5,6	5,8	6,2	4,3	4,0	3,5
26	4,7	5,2	5,3	4,2	3,9	3,4
28	4,0	4,4	4,7	4,0	3,8	3,4
30	3,4	3,7	4,0	3,4	3,7	3,3
32	2,8	3,2	3,4	3,0	3,4	3,3
34	2,4	2,7	2,9	2,5	3,1	3,2
36	2,0	2,2	2,4	2,2	2,7	2,9
38	1,6	1,9	2,0	1,8	2,3	2,6
40	1,3	1,5	1,6	1,5	1,9	2,2
42	1,0	1,2	1,3	1,2	1,6	1,9
44	0,8	0,9	1,0	0,9	1,3	1,5
46	-	-	-	0,7	1,0	1,2
48	-	-	-	-	0,8	1,0

41,8 m

m	10,1 m			19,0 m		
	0°	20°	40°	0°	20°	40°
10	10,9	-	-	-	-	-
12	10,7	-	-	5,4	-	-
14	10,4	9,3	-	5,3	-	-
16	10,0	9,0	7,7	5,2	-	-
18	8,7	8,7	7,6	5,1	4,7	-
20	7,8	7,9	7,4	5,0	4,5	-
22	6,6	7,0	7,1	4,8	4,4	-
24	5,6	6,0	6,4	4,7	4,2	3,6
26	4,7	5,2	5,5	4,5	4,1	3,5
28	4,0	4,4	4,7	4,2	4,0	3,5
30	3,4	3,7	4,0	3,6	3,9	3,4
32	2,9	3,2	3,4	3,1	3,7	3,3
34	2,4	2,7	2,9	2,6	3,2	3,3
36	2,0	2,2	2,4	2,2	2,7	3,1
38	1,6	1,9	2,0	1,8	2,3	2,6
40	1,3	1,5	1,6	1,5	1,9	2,2
42	1,1	1,2	-	1,2	1,6	1,9
44	0,8	0,9	-	1,0	1,3	1,5
46	-	-	-	0,7	1,0	1,2
48	-	-	-	-	0,8	0,9

11,9 m

m	10,1 m			19,0 m		
	0°	20°	40°	0°	20°	40°
3	13,4	-	-	9,0	-	-
4	13,4	-	-	8,8	-	-
5	13,4	13,4	-	8,6	-	-
6	13,4	12,8	-	8,5	-	-
7	13,3	12,0	-	8,2	-	-
8	12,9	11,4	9,5	8,0	-	-
9	12,5	10,8	9,1	7,7	-	-
10	12,1	10,3	8,7	7,4	6,5	-
12	11,0	9,3	8,1	6,9	5,9	-
14	9,8	8,5	7,7	6,3	5,5	-
16	8,8	7,9	7,5	5,7	5,0	4,3
18	7,9	7,5	-	5,3	4,7	4,1
20	-	-	-	4,9	4,4	3,9
22	-	-	-	4,5	4,1	3,7
24	-	-	-	4,2	3,9	3,7
26	-	-	-	3,9	3,8	-

9,0 t 8,10 m x 7,20 m 360° ISO

50,0 m

m	10,1 m			19,0 m		
	0°	20°	40°	0°	20°	40°
12	6,7	-	-	-	-	-
14	6,7	-	-	3,7	-	-
16	6,7	-	-	3,7	-	-
18	6,5	6,7	-	3,7	-	-
20	5,3	6,0	5,9	3,7	-	-
22	4,3	4,9	5,5	3,7	3,7	-
24	3,5	4,0	4,6	3,3	3,7	-
26	2,8	3,3	3,8	2,7	3,6	3,3
28	2,3	2,7	3,1	2,2	3,0	3,2
30	1,8	2,2	2,6	1,7	2,5	3,2
32	1,4	1,8	2,1	1,3	2,0	2,7
34	1,0	1,4	1,7	1,0	1,6	2,2
36	0,7	1,0	1,3	-	1,3	1,8
38	-	0,7	0,9	-	1,0	1,4
40	-	-	-	-	-	1,1
42	-	-	-	-	-	0,8

45,2 m

m	10,1 m			19,0 m		
	0°	20°	40°	0°	20°	40°
12	8,6	-	-	4,6	-	-
14	8,5	-	-	4,6	-	-
16	8,2	8,2	-	4,6	-	-
18	7,2	7,5	7,2	4,6	-	-
20	5,9	6,4	6,9	4,5	4,2	-
22	4,9	5,5	5,7	4,4	4,1	-
24	4,1	4,6	5,1	4,0	4,0	3,5
26	3,4	3,8	4,2	3,3	3,9	3,4
28	2,8	3,2	3,5	2,7	3,5	3,4
30	2,3	2,7	2,9	2,3	3,0	3,3
32	1,8	2,2	2,4	1,8	2,5	3,1
34	1,4	1,7	1,9	1,5	2,1	2,6
36	1,1	1,4	1,5	1,2	1,7	2,2
38	0,8	1,0	1,2	0,9	1,4	1,8
40	-	0,7	0,9	-	1,1	1,4
42	-	-	-	-	0,8	1,1
44	-	-	-	-	-	0,8

41,8 m

m	10,1 m			19,0 m		
	0°	20°	40°	0°	20°	40°
10	10,9	-	-	-	-	-
12	10,7	-	-	5,4	-	-
14	10,1	9,3	-	5,3	-	-
16	8,8	9,0	7,7	5,2	-	-
18	7,3	8,0	7,6	5,1	4,7	-
20	6,1	6,7	7,3	5,0	4,5	-
22	5,1	5,6	6,1	4,6	4,4	-
24	4,2	4,7	5,1	4,1	4,2	3,6
26	3,4	3,9	4,3	3,5	4,0	3,5
28	2,8	3,2	3,5	2,9	3,6	3,5
30	2,3	2,7	2,9	2,4	3,1	3,4
32	1,8	2,2	2,4	2,0	2,6	3,2
34	1,5	1,7	1,9	1,6	2,2	2,7
36	1,1	1,4	1,5	1,3	1,8	2,2
38	0,8	1,0	1,1	1,0	1,4	1,8
40	-	0,7	0,8	0,7	1,1	1,4
42	-	-	-	-	0,8	1,1
44	-	-	-	-	-	0,8

11,9 m

m	10,1 m			19,0 m		
	0°	20°	40°	0°	20°	40°
3	13,4	-	-	9,0	-	-
4	13,4	-	-	8,8	-	-
5	13,4	13,4	-	8,6	-	-
6	13,4	12,8	-	8,5	-	-
7	13,3	12,0	-	8,2	-	-
8	12,9	11,4	9,5	8,0	-	-
9	12,5	10,8	9,1	7,7	-	-
10	12,1	10,3	8,7	7,4	6,5	-
12	11,0	9,3	8,1	6,9	5,9	-
14	9,8	8,5	7,7	6,3	5,5	-
16	8,8	7,9	7,5	5,7	5,0	4,3
18	7,9	7,5	-	5,3	4,7	4,1
20	-	-	-	4,9	4,4	3,9
22	-	-	-	4,5	4,1	3,7
24	-	-	-	4,2	3,9	3,7
26	-	-	-	3,9	3,8	-

6,1 t 8,10 m x 7,20 m 360° ISO

50,0 m

m	10,1 m			19,0 m		
	0°	20°	40°	0°	20°	40°
12	6,7	-	-	-	-	-
14	6,7	-	-	3,7	-	-
16	6,7	-	-	3,7	-	-
18	5,4	6,2	-	3,7	-	-
20	4,2	5,0	5,7	3,7	-	-
22	3,4	4,0	4,6	3,2	3,7	-
24	2,6	3,2	3,7	2,5	3,6	-
26	2,1	2,6	3,0	2,0	2,9	3,3
28	1,6	2,0	2,4	1,5	2,3	3,1
30	1,1	1,6	1,9	1,1	1,8	2,5
32	0,8	1,2	1,5	0,7	1,4	2,1
34	-	0,8	1,1	-	1,1	1,6
36	-	-	0,8	-	0,7	1,3
38	-	-	-	-	-	0,9

45,2 m

m	10,1 m			19,0 m		
	0°	20°	40°	0°	20°	40°
12	8,6	-	-	4,6	-	-
14	8,5	-	-	4,6	-	-
16	7,4	7,8	-	4,6	-	-
18	6,1	6,8	7,1	4,6	-	-
20	4,9	5,6	6,0	4,4	4,2	-
22	4,0	4,6	5,1	3,9	4,1	-
24	3,2	3,8	4,2	3,1	4,0	3,5
26	2,6	3,1	3,5	2,5	3,4	3,4
28	2,1	2,5	2,9	2,0	2,8	3,3
30	1,7	2,0	2,3	1,6	2,3	2,9
32	1,3	1,6	1,9	1,2	1,9	2,5
34	0,9	1,2	1,4	0,9	1,5	2,0
36	-	0,9	1,1	-	1,2	1,6
38	-	-	0,7	-	0,9	1,3
40	-	-	-	-	-	1,0
42	-	-	-	-	-	0,7

41,8 m

m	10,1 m			19,0 m		
	0°	20°	40°	0°	20°	40°
10	10,9	-	-	-	-	-
12	10,7	-	-	5,4	-	-
14	9,3	9,3	-	5,3	-	-
16	7,6	8,4	7,7	5,2	-	-
18	6,2	6,9	7,4	5,1	4,7	-
20	5,1	5,8	6,3	4,8	4,5	-
22	4,1	4,7	5,2	4,1	4,4	-
24	3,4	3,9	4,3	3,3	4,1	3,6
26	2,7	3,2	3,6	2,7	3,5	3,5
28	2,2	2,6	2,9	2,2	2,9	3,4
30	1,7	2,1	2,3	1,8	2,4	3,1
32	1,3	1,6	1,8	1,4	2,0	2,6
34	0,9	1,2	1,4	1,1	1,6	2,1
36	-	0,9	1,0	0,8	1,3	1,7
38	-	-	-	-	1,0	1,4
40	-	-	-	-	0,7	1,0
42	-	-	-	-	-	0,7

11,9 m

m	10,1 m			19,0 m		
	0°	20°	40°	0°	20°	40°
3	13,4	-	-	9,0	-	-
4	13,4	-	-	8,8	-	-
5	13,4	13,4	-	8,6	-	-
6	13,4	12,8	-	8,5	-	-
7	13,3	12,0	-	8,2	-	-
8	12,9	11,4	9,5	8,0	-	-
9	12,5	10,8	9,1	7,7	-	-
10	12,1	10,3	8,7	7,4	6,5	-
12	11,0	9,3	8,1	6,9	5,9	-
14	9,8	8,5	7,7	6,3	5,5	-
16	8,8	7,9	7,5	5,7	5,0	4,3
18	7,5	7,5	-	5,3	4,7	4,1
20	-	-	-	4,9	4,4	3,9
22	-	-	-	4,5	4,1	3,7
24	-	-	-	4,2	3,9	3,7
26	-	-	-	3,9	3,8	-

4,5 t 8,10 m x 7,20 m 360° ISO

50,0 m

m	10,1 m			19,0 m		
	0°	20°	40°	0°	20°	40°
12	6,7	-	-	-	-	-
14	6,7	-	-	3,7	-	-
16	6,0	-	-	3,7	-	-
18	4,7	5,5	-	3,7	-	-
20	3,6	4,4	5,1	3,5	-	-
22	2,8	3,5	4,0	2,7	3,7	-
24	2,2	2,7	3,2	2,0	3,1	-
26	1,6	2,1	2,6	1,5	2,4	3,3
28	1,2	1,6	2,0	1,1	1,9	2,7
30	0,8	1,2	1,5	-	1,5	2,2
32	-	0,8	1,1	-	1,1	1,7
34	-	-	0,8	-	0,7	1,3
36	-	-	-	-	-	0,9

45,2 m

m	10,1 m			19,0 m		
	0°	20°	40°	0°	20°	40°
12	8,6	-	-	4,6	-	-
14	8,0	-	-	4,6	-	-
16	6,7	7,3	-	4,6	-	-
18	5,4	6,2	6,5	4,6	-	-
20	4,3	5,0	5,6	4,2	4,2	-
22	3,4	4,0	4,6	3,3	4,1	-
24	2,8	3,3	3,7	2,7	3,6	3,5
26	2,2	2,6	3,0	2,1	3,0	3,4
28	1,7	2,1	2,5	1,6	2,4	3,1
30	1,3	1,7	2,0	1,2	1,9	2,6
32	0,9	1,3	1,5	0,9	1,5	2,1
34	-	0,9	1,1	-	1,2	1,7
36	-	-	0,8	-	0,9	1,3
38	-	-	-	-	-	1,0
40	-	-	-	-	-	0,7

41,8 m

m	10,1 m			19,0 m		
	0°	20°	40°	0°	20°	40°
10	10,9	-	-	-	-	-
12	10,0	-	-	5,4	-	-
14	8,5	9,0	-	5,3	-	-
16	6,8	7,7	7,7	5,2	-	-
18	5,6	6,3	6,9	5,0	4,7	-
20	4,5	5,2	5,7	4,4	4,5	-
22	3,6	4,2	4,7	3,5	4,3	-
24	2,9	3,4	3,8	2,8	3,8	3,6
26	2,3	2,8	3,1	2,3	3,1	3,5
28	1,8	2,2	2,5	1,8	2,5	3,2
30	1,4	1,7	2,0	1,4	2,1	2,7
32	1,0	1,3	1,5	1,0	1,6	2,2
34	-	0,9	1,1	0,7	1,3	1,8
36	-	-	0,8	-	1,0	1,4
38	-	-	-	-	-	1,1
40	-	-	-	-	-	0,8

11,9 m

m	10,1 m			19,0 m		
	0°	20°	40°	0°	20°	40°
3	13,4	-	-	9,0	-	-
4	13,4	-	-	8,8	-	-
5	13,4	13,4	-	8,6	-	-
6	13,4	12,8	-	8,5	-	-
7	13,3	12,0	-	8,2	-	-
8	12,9	11,4	9,5	8,0	-	-
9	12,5	10,8	9,1	7,7	-	-
10	12,1	10,3	8,7	7,4	6,5	-
12	11,0	9,3	8,1	6,9	5,9	-
14	9,8	8,5	7,7	6,3	5,5	-
16	8,4	7,9	7,5	5,7	5,0	4,3
18	6,9	7,1	-	5,3	4,7	4,1
20	-	-	-	4,9	4,4	3,9
22	-	-	-	4,5	4,1	3,7
24	-	-	-	4,2	3,9	3,7
26	-	-	-	3,9	3,8	-

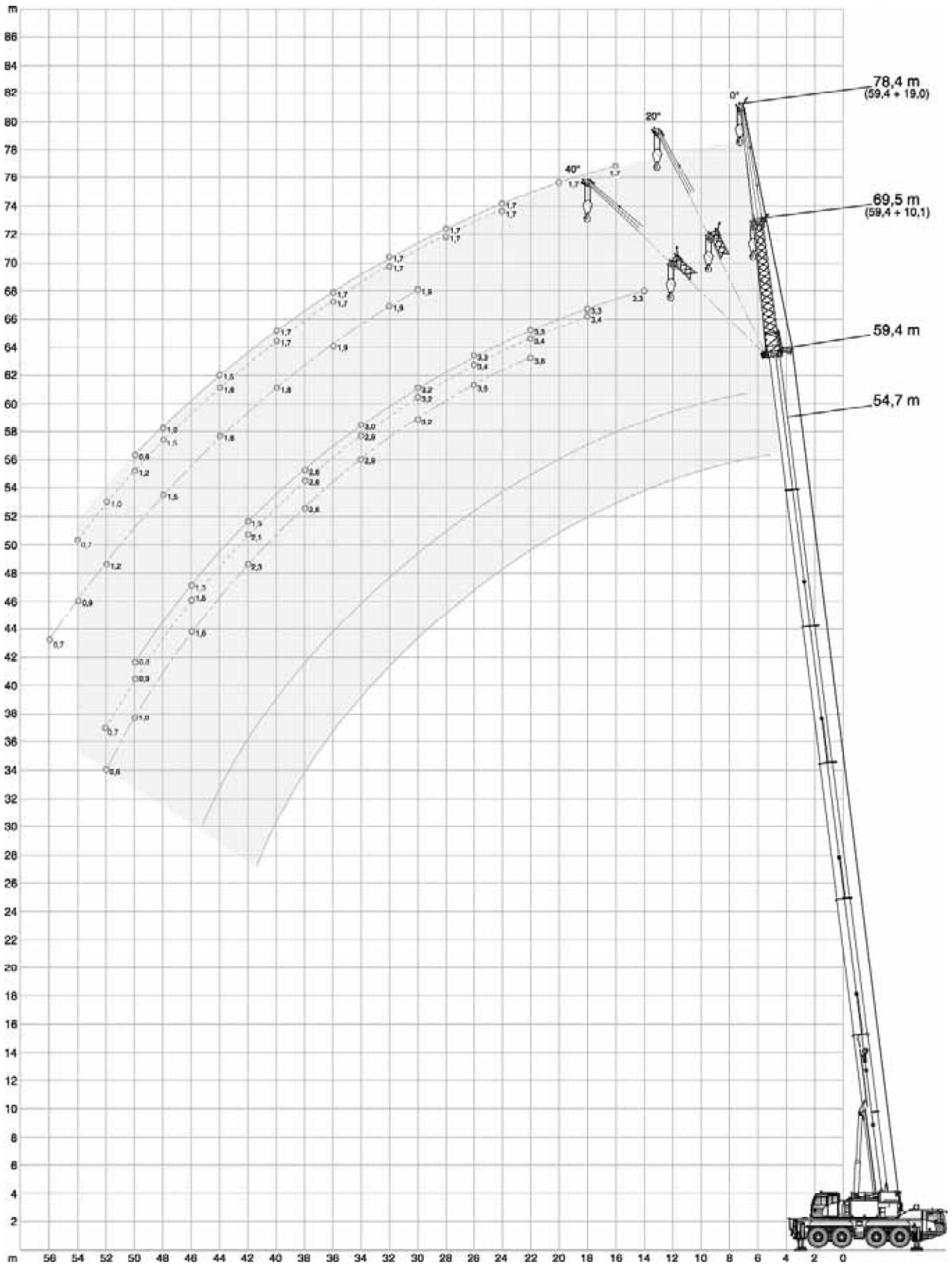
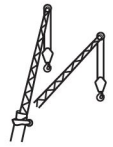

25,2 t 8,10 m x 7,20 m 360° ISO

59,4 m

m	10,1 m			19,0 m		
	0°	20°	40°	0°	20°	40°
14	3,3	-	-	-	-	-
16	3,3	-	-	1,7	-	-
18	3,3	3,4	-	1,7	-	-
20	3,3	3,4	-	1,7	-	-
22	3,3	3,4	3,6	1,7	-	-
24	3,3	3,4	3,6	1,7	1,7	-
26	3,3	3,4	3,5	1,7	1,7	-
28	3,2	3,3	3,3	1,7	1,7	-
30	3,2	3,2	3,2	1,7	1,7	1,9
32	3,1	3,0	3,0	1,7	1,7	1,9
34	3,0	2,9	2,9	1,7	1,7	1,9
36	2,9	2,8	2,8	1,7	1,7	1,9
38	2,6	2,6	2,6	1,7	1,7	1,9
40	2,2	2,5	2,5	1,7	1,7	1,8
42	1,9	2,2	2,3	1,6	1,7	1,7
44	1,6	1,8	2,0	1,5	1,6	1,6
46	1,3	1,5	1,6	1,3	1,6	1,5
48	1,0	1,2	1,3	1,0	1,5	1,5
50	0,8	0,9	1,0	0,8	1,2	1,4
52	-	0,7	0,8	-	1,0	1,2
54	-	-	-	-	0,7	0,9
56	-	-	-	-	-	0,7

54,6 m

m	10,1 m			19,0 m		
	0°	20°	40°	0°	20°	40°
14	4,7	-	-	2,5	-	-
16	4,7	-	-	2,5	-	-
18	4,7	4,7	-	2,5	-	-
20	4,7	4,7	-	2,5	-	-
22	4,7	4,7	5,0	2,5	2,5	-
24	4,5	4,7	4,8	2,5	2,5	-
26	4,4	4,6	4,7	2,5	2,5	-
28	4,3	4,4	4,5	2,5	2,5	2,8
30	4,1	4,2	4,3	2,5	2,5	2,8
32	3,9	4,0	4,0	2,5	2,5	2,7
34	3,7	3,7	3,8	2,5	2,5	2,6
36	3,2	3,5	3,6	2,5	2,5	2,5
38	2,7	3,0	3,2	2,4	2,5	2,5
40	2,5	2,6	2,8	2,3	2,5	2,4
42	2,2	2,4	2,4	2,0	2,4	2,4
44	1,9	2,1	2,2	1,7	2,2	2,3
46	1,6	1,8	1,9	1,6	1,9	2,2
48	1,3	1,5	1,6	1,4	1,6	1,8
50	1,1	1,2	1,3	1,2	1,4	1,5
52	0,9	1,0	1,1	0,9	1,3	1,3
54	-	0,8	-	0,7	1,0	1,2
56	-	-	-	-	0,8	1,0
58	-	-	-	-	-	0,7

49,9 m

m	10,1 m			19,0 m		
	0°	20°	40°	0°	20°	40°
12	6,3	-	-	-	-	-
14	6,3	-	-	3,5	-	-
16	6,3	6,3	-	3,5	-	-
18	6,2	6,3	-	3,5	-	-
20	6,1	6,1	6,3	3,5	-	-
22	5,8	5,9	6,0	3,5	3,4	-
24	5,5	5,7	5,7	3,4	3,4	-
26	5,2	5,3	5,4	3,4	3,4	-
28	4,9	5,0	5,1	3,3	3,4	3,2
30	4,6	4,6	4,7	3,3	3,4	3,2
32	4,1	4,3	4,4	3,3	3,3	3,1
34	3,8	3,9	4,1	3,1	3,2	3,1
36	3,5	3,6	3,6	3,0	3,1	3,0
38	3,0	3,3	3,4	2,7	3,1	3,0
40	2,6	2,8	3,0	2,4	2,8	3,0
42	2,2	2,5	2,6	2,3	2,4	2,8
44	2,1	2,1	2,2	2,0	2,3	2,4
46	1,9	1,9	1,9	1,7	2,1	2,1
48	1,7	1,7	1,8	1,4	1,8	2,0
50	1,5	1,6	-	1,3	1,5	1,7
52	1,3	1,4	-	1,2	1,3	1,5
54	1,1	1,1	-	1,1	1,1	1,2
56	-	-	-	0,9	1,0	1,1
58	-	-	-	0,7	0,9	-
60	-	-	-	-	0,7	-

12,0 m

m	10,1 m			19,0 m		
	0°	20°	40°	0°	20°	40°
3	13,4	-	-	8,7	-	-
4	13,4	-	-	8,6	-	-
5	13,4	13,4	-	8,4	-	-
6	13,4	12,8	-	8,3	-	-
7	13,3	12,0	-	8,0	-	-
8	12,9	11,4	9,4	7,8	-	-
9	12,5	10,8	9,0	7,6	-	-
10	12,1	10,2	8,7	7,3	6,4	-
12	11,0	9,3	8,1	6,8	5,9	-
14	9,8	8,5	7,7	6,2	5,4	-
16	8,8	7,9	7,5	5,7	5,0	4,3
18	7,9	7,6	-	5,3	4,7	4,1
20	-	-	-	4,9	4,4	3,9
22	-	-	-	4,5	4,1	3,7
24	-	-	-	4,2	3,9	3,7
26	-	-	-	3,9	3,8	-

20,2 t  8,10 m x 7,20 m 360° ISO

 **59,4 m**

m	10,1 m			19,0 m		
	0°	20°	40°	0°	20°	40°
14	3,3	-	-	-	-	-
16	3,3	-	-	1,7	-	-
18	3,3	3,4	-	1,7	-	-
20	3,3	3,4	-	1,7	-	-
22	3,3	3,4	3,6	1,7	-	-
24	3,3	3,4	3,6	1,7	1,7	-
26	3,3	3,4	3,5	1,7	1,7	-
28	3,2	3,3	3,3	1,7	1,7	-
30	3,2	3,2	3,2	1,7	1,7	1,9
32	3,1	3,0	3,0	1,7	1,7	1,9
34	2,6	2,9	2,9	1,7	1,7	1,9
36	2,2	2,6	2,8	1,7	1,7	1,9
38	1,9	2,2	2,4	1,7	1,7	1,9
40	1,5	1,8	2,1	1,4	1,7	1,8
42	1,2	1,5	1,7	1,1	1,6	1,7
44	0,9	1,2	1,3	0,8	1,3	1,6
46	-	0,9	1,0	-	1,1	1,5
48	-	-	0,8	-	0,8	1,2
50	-	-	-	-	-	0,9

 **54,6 m**

m	10,1 m			19,0 m		
	0°	20°	40°	0°	20°	40°
14	4,7	-	-	2,5	-	-
16	4,7	-	-	2,5	-	-
18	4,7	4,7	-	2,5	-	-
20	4,7	4,7	-	2,5	-	-
22	4,7	4,7	5,0	2,5	2,5	-
24	4,5	4,7	4,8	2,5	2,5	-
26	4,4	4,6	4,7	2,5	2,5	-
28	4,3	4,4	4,5	2,5	2,5	2,8
30	3,9	4,2	4,3	2,5	2,5	2,8
32	3,3	3,8	4,0	2,5	2,5	2,7
34	3,0	3,2	3,5	2,5	2,5	2,6
36	2,7	2,8	3,0	2,3	2,5	2,5
38	2,2	2,5	2,6	1,9	2,5	2,5
40	1,9	2,1	2,3	1,8	2,2	2,4
42	1,6	1,8	2,0	1,6	1,8	2,3
44	1,3	1,5	1,6	1,3	1,6	1,9
46	1,0	1,2	1,3	1,1	1,5	1,6
48	0,8	0,9	1,0	0,8	1,2	1,5
50	-	-	0,8	-	0,9	1,2
52	-	-	-	-	0,7	0,9

 **49,9 m**

m	10,1 m			19,0 m		
	0°	20°	40°	0°	20°	40°
12	6,3	-	-	-	-	-
14	6,3	-	-	3,5	-	-
16	6,3	6,3	-	3,5	-	-
18	6,2	6,3	-	3,5	-	-
20	6,1	6,1	6,3	3,5	-	-
22	5,8	5,9	6,0	3,5	3,4	-
24	5,5	5,7	5,7	3,4	3,4	-
26	5,2	5,3	5,4	3,4	3,4	-
28	4,5	5,0	5,1	3,3	3,4	3,2
30	4,3	4,3	4,6	3,3	3,4	3,2
32	3,7	4,0	4,1	3,2	3,3	3,1
34	3,1	3,5	3,7	2,8	3,2	3,1
36	2,8	3,0	3,2	2,6	3,0	3,0
38	2,6	2,5	2,7	2,4	2,6	3,0
40	2,3	2,4	2,4	2,0	2,5	2,6
42	1,9	2,1	2,2	1,7	2,1	2,3
44	1,7	1,8	1,9	1,6	1,8	2,1
46	1,4	1,5	1,6	1,4	1,5	1,8
48	1,2	1,3	1,3	1,2	1,4	1,5
50	0,9	1,0	-	1,0	1,3	1,3
52	0,8	0,8	-	0,8	1,0	1,2
54	-	-	-	-	0,8	1,0
56	-	-	-	-	-	0,7

 **12,0 m**

m	10,1 m			19,0 m		
	0°	20°	40°	0°	20°	40°
3	13,4	-	-	8,7	-	-
4	13,4	-	-	8,6	-	-
5	13,4	13,4	-	8,4	-	-
6	13,4	12,8	-	8,3	-	-
7	13,3	12,0	-	8,0	-	-
8	12,9	11,4	9,4	7,8	-	-
9	12,5	10,8	9,0	7,6	-	-
10	12,1	10,2	8,7	7,3	6,4	-
12	11,0	9,3	8,1	6,8	5,9	-
14	9,8	8,5	7,7	6,2	5,4	-
16	8,8	7,9	7,5	5,7	5,0	4,3
18	7,9	7,6	-	5,3	4,7	4,1
20	-	-	-	4,9	4,4	3,9
22	-	-	-	4,5	4,1	3,7
24	-	-	-	4,2	3,9	3,7
26	-	-	-	3,9	3,8	-

14,2 t 8,10 m x 7,20 m 360° ISO

59,4 m

m	10,1 m			19,0 m		
	0°	20°	40°	0°	20°	40°
14	3,3	-	-	-	-	-
16	3,3	-	-	1,7	-	-
18	3,3	3,4	-	1,7	-	-
20	3,3	3,4	-	1,7	-	-
22	3,3	3,4	3,6	1,7	-	-
24	3,3	3,4	3,6	1,7	1,7	-
26	3,3	3,4	3,5	1,7	1,7	-
28	2,9	3,3	3,3	1,7	1,7	-
30	2,4	2,8	3,2	1,7	1,7	1,9
32	1,9	2,3	2,7	1,7	1,7	1,9
34	1,5	1,9	2,2	1,3	1,7	1,9
36	1,1	1,5	1,8	1,0	1,7	1,9
38	0,8	1,2	1,4	-	1,3	1,9
40	-	0,9	1,1	-	1,0	1,5
42	-	-	0,8	-	0,7	1,2
44	-	-	-	-	-	0,9

54,6 m

m	10,1 m			19,0 m		
	0°	20°	40°	0°	20°	40°
14	4,7	-	-	2,5	-	-
16	4,7	-	-	2,5	-	-
18	4,7	4,7	-	2,5	-	-
20	4,7	4,7	-	2,5	-	-
22	4,7	4,7	5,0	2,5	2,5	-
24	4,5	4,7	4,8	2,5	2,5	-
26	3,9	4,4	4,7	2,5	2,5	-
28	3,5	3,7	4,1	2,5	2,5	2,8
30	2,9	3,3	3,5	2,5	2,5	2,8
32	2,5	2,8	3,0	2,1	2,5	2,7
34	2,0	2,4	2,7	1,9	2,3	2,6
36	1,7	2,0	2,3	1,5	2,0	2,5
38	1,3	1,6	1,9	1,2	1,8	2,1
40	1,0	1,3	1,5	0,9	1,5	1,8
42	0,7	1,0	1,1	-	1,2	1,6
44	-	0,7	0,8	-	0,9	1,3
46	-	-	-	-	-	1,0
48	-	-	-	-	-	0,8

49,9 m

m	10,1 m			19,0 m		
	0°	20°	40°	0°	20°	40°
12	6,3	-	-	-	-	-
14	6,3	-	-	3,5	-	-
16	6,3	6,3	-	3,5	-	-
18	6,2	6,3	-	3,5	-	-
20	6,1	6,1	6,3	3,5	-	-
22	5,6	5,9	6,0	3,5	3,4	-
24	4,9	5,3	5,7	3,4	3,4	-
26	4,4	4,8	4,9	3,4	3,4	-
28	3,7	4,1	4,5	3,1	3,4	3,2
30	3,4	3,5	3,9	2,9	3,4	3,2
32	3,0	3,0	3,3	2,5	2,9	3,1
34	2,5	2,8	2,8	2,2	2,7	3,0
36	2,1	2,4	2,6	2,1	2,3	2,6
38	1,8	2,0	2,2	1,8	1,9	2,4
40	1,4	1,7	1,8	1,5	1,8	2,0
42	1,1	1,3	1,5	1,2	1,6	1,7
44	0,9	1,1	1,2	1,0	1,3	1,6
46	-	0,8	0,9	0,7	1,1	1,3
48	-	-	-	-	0,8	1,1
50	-	-	-	-	-	0,8

12,0 m

m	10,1 m			19,0 m		
	0°	20°	40°	0°	20°	40°
3	13,4	-	-	8,7	-	-
4	13,4	-	-	8,6	-	-
5	13,4	13,4	-	8,4	-	-
6	13,4	12,8	-	8,3	-	-
7	13,3	12,0	-	8,0	-	-
8	12,9	11,4	9,4	7,8	-	-
9	12,5	10,8	9,0	7,6	-	-
10	12,1	10,2	8,7	7,3	6,4	-
12	11,0	9,3	8,1	6,8	5,9	-
14	9,8	8,5	7,7	6,2	5,4	-
16	8,8	7,9	7,5	5,7	5,0	4,3
18	7,9	7,6	-	5,3	4,7	4,1
20	-	-	-	4,9	4,4	3,9
22	-	-	-	4,5	4,1	3,7
24	-	-	-	4,2	3,9	3,7
26	-	-	-	3,9	3,8	-

9,0 t  8,10 m x 7,20 m 360° **ISO**

59,4 m

m	10,1 m			19,0 m		
	0°	20°	40°	0°	20°	40°
14	3,3	-	-	-	-	-
16	3,3	-	-	1,7	-	-
18	3,3	3,4	-	1,7	-	-
20	3,3	3,4	-	1,7	-	-
22	3,3	3,4	3,6	1,7	-	-
24	2,8	3,4	3,6	1,7	1,7	-
26	2,2	2,7	3,3	1,7	1,7	-
28	1,6	2,2	2,6	1,4	1,7	-
30	1,2	1,7	2,1	1,0	1,7	1,9
32	0,8	1,2	1,6	-	1,4	1,9
34	-	0,9	1,2	-	1,0	1,7
36	-	-	0,8	-	-	1,3
38	-	-	-	-	-	1,0

54,6 m

m	10,1 m			19,0 m		
	0°	20°	40°	0°	20°	40°
14	4,7	-	-	2,5	-	-
16	4,7	-	-	2,5	-	-
18	4,7	4,7	-	2,5	-	-
20	4,7	4,7	-	2,5	-	-
22	4,1	4,6	5,0	2,5	2,5	-
24	3,4	3,9	4,3	2,5	2,5	-
26	2,8	3,3	3,5	2,3	2,5	-
28	2,2	2,7	3,1	2,0	2,5	2,8
30	1,7	2,2	2,5	1,6	2,2	2,8
32	1,3	1,7	2,1	1,2	1,9	2,4
34	1,0	1,3	1,6	0,8	1,5	2,1
36	-	1,0	1,3	-	1,2	1,7
38	-	0,7	0,9	-	0,9	1,4
40	-	-	-	-	-	1,0
42	-	-	-	-	-	0,8

49,9 m

m	10,1 m			19,0 m		
	0°	20°	40°	0°	20°	40°
12	6,3	-	-	-	-	-
14	6,3	-	-	3,5	-	-
16	6,3	6,3	-	3,5	-	-
18	6,1	6,3	-	3,5	-	-
20	5,3	5,7	6,3	3,5	-	-
22	4,5	5,1	5,3	3,5	3,4	-
24	4,0	4,2	4,7	3,0	3,4	-
26	3,4	3,6	3,9	2,8	3,4	-
28	2,8	3,3	3,3	2,5	3,0	3,2
30	2,3	2,7	3,1	2,2	2,6	3,0
32	1,9	2,3	2,6	1,8	2,2	2,7
34	1,6	1,9	2,1	1,4	2,0	2,3
36	1,2	1,5	1,7	1,1	1,7	1,9
38	0,9	1,2	1,3	0,8	1,3	1,8
40	-	0,9	1,0	-	1,1	1,5
42	-	-	0,7	-	0,8	1,2
44	-	-	-	-	-	0,9

12,0 m

m	10,1 m			19,0 m		
	0°	20°	40°	0°	20°	40°
3	13,4	-	-	8,7	-	-
4	13,4	-	-	8,6	-	-
5	13,4	13,4	-	8,4	-	-
6	13,4	12,8	-	8,3	-	-
7	13,3	12,0	-	8,0	-	-
8	12,9	11,4	9,4	7,8	-	-
9	12,5	10,8	9,0	7,6	-	-
10	12,1	10,2	8,7	7,3	6,4	-
12	11,0	9,3	8,1	6,8	5,9	-
14	9,8	8,5	7,7	6,2	5,4	-
16	8,8	7,9	7,5	5,7	5,0	4,3
18	7,9	7,6	-	5,3	4,7	4,1
20	-	-	-	4,9	4,4	3,9
22	-	-	-	4,5	4,1	3,7
24	-	-	-	4,2	3,9	3,7
26	-	-	-	3,9	3,8	-

6,1 t 8,10 m x 7,20 m 360° ISO

59,4 m

m	10,1 m			19,0 m		
	0°	20°	40°	0°	20°	40°
14	3,3	-	-	-	-	-
16	3,3	-	-	1,7	-	-
18	3,3	3,4	-	1,7	-	-
20	3,3	3,4	-	1,7	-	-
22	2,7	3,4	3,6	1,7	-	-
24	2,0	2,6	3,2	1,7	1,7	-
26	1,4	2,0	2,5	1,2	1,7	-
28	0,9	1,5	1,9	0,7	1,7	-
30	-	1,0	1,4	-	1,2	-
32	-	-	1,0	-	0,8	-

54,6 m

m	10,1 m			19,0 m		
	0°	20°	40°	0°	20°	40°
14	4,7	-	-	2,5	-	-
16	4,7	-	-	2,5	-	-
18	4,7	4,7	-	2,5	-	-
20	4,2	4,7	-	2,5	-	-
22	3,3	4,0	4,3	2,5	2,5	-
24	2,6	3,2	3,7	2,3	2,5	-
26	2,0	2,5	3,0	1,8	2,5	-
28	1,5	2,0	2,4	1,3	2,2	2,8
30	1,1	1,5	1,9	0,9	1,7	2,3
32	0,7	1,1	1,5	-	1,3	2,0
34	-	0,8	1,1	-	1,0	1,6
36	-	-	0,7	-	-	1,2
38	-	-	-	-	-	0,9

49,9 m

m	10,1 m			19,0 m		
	0°	20°	40°	0°	20°	40°
12	6,3	-	-	-	-	-
14	6,3	-	-	3,5	-	-
16	6,3	6,3	-	3,5	-	-
18	5,5	5,9	-	3,5	-	-
20	4,5	5,2	5,4	3,5	-	-
22	4,0	4,2	4,8	3,0	3,4	-
24	3,3	3,8	3,9	2,6	3,4	-
26	2,7	3,1	3,5	2,5	3,0	-
28	2,1	2,6	2,9	2,0	2,4	3,0
30	1,7	2,1	2,4	1,5	2,3	2,7
32	1,3	1,7	2,0	1,2	1,8	2,2
34	1,0	1,3	1,6	0,9	1,5	2,0
36	0,7	1,0	1,2	-	1,1	1,6
38	-	0,7	0,9	-	0,8	1,3
40	-	-	-	-	-	1,0
42	-	-	-	-	-	0,7

12,0 m

m	10,1 m			19,0 m		
	0°	20°	40°	0°	20°	40°
3	13,4	-	-	8,7	-	-
4	13,4	-	-	8,6	-	-
5	13,4	13,4	-	8,4	-	-
6	13,4	12,8	-	8,3	-	-
7	13,3	12,0	-	8,0	-	-
8	12,9	11,4	9,4	7,8	-	-
9	12,5	10,8	9,0	7,6	-	-
10	12,1	10,2	8,7	7,3	6,4	-
12	11,0	9,3	8,1	6,8	5,9	-
14	9,8	8,5	7,7	6,2	5,4	-
16	8,8	7,9	7,5	5,7	5,0	4,3
18	7,6	7,6	-	5,3	4,7	4,1
20	-	-	-	4,9	4,4	3,9
22	-	-	-	4,5	4,1	3,7
24	-	-	-	4,2	3,9	3,7
26	-	-	-	3,9	3,8	-

 4,5 t

 8,10 m x 7,20 m

360°

ISO

 59,4 m

m	10,1 m			19,0 m		
	0°	20°	40°	0°	20°	40°
14	3,3	-	-	-	-	-
16	3,3	-	-	1,7	-	-
18	3,3	3,4	-	1,7	-	-
20	2,9	3,4	-	1,7	-	-
22	2,1	2,8	3,5	1,7	-	-
24	1,5	2,1	2,7	1,2	-	-
26	1,0	1,5	2,1	0,7	-	-
28	-	1,1	1,5	-	-	-
30	-	-	1,0	-	-	-

 54,6 m

m	10,1 m			19,0 m		
	0°	20°	40°	0°	20°	40°
14	4,7	-	-	2,5	-	-
16	4,7	-	-	2,5	-	-
18	4,3	4,7	-	2,5	-	-
20	3,6	4,2	4,2	2,5	-	-
22	2,8	3,5	4,0	2,3	2,5	-
24	2,1	2,7	3,2	1,9	2,5	-
26	1,6	2,1	2,6	1,4	2,3	-
28	1,1	1,6	2,0	0,9	1,8	2,3
30	0,7	1,2	1,5	-	1,4	2,1
32	-	0,8	1,1	-	1,0	1,6
34	-	-	0,7	-	-	1,2
36	-	-	-	-	-	0,9







 49,9 m

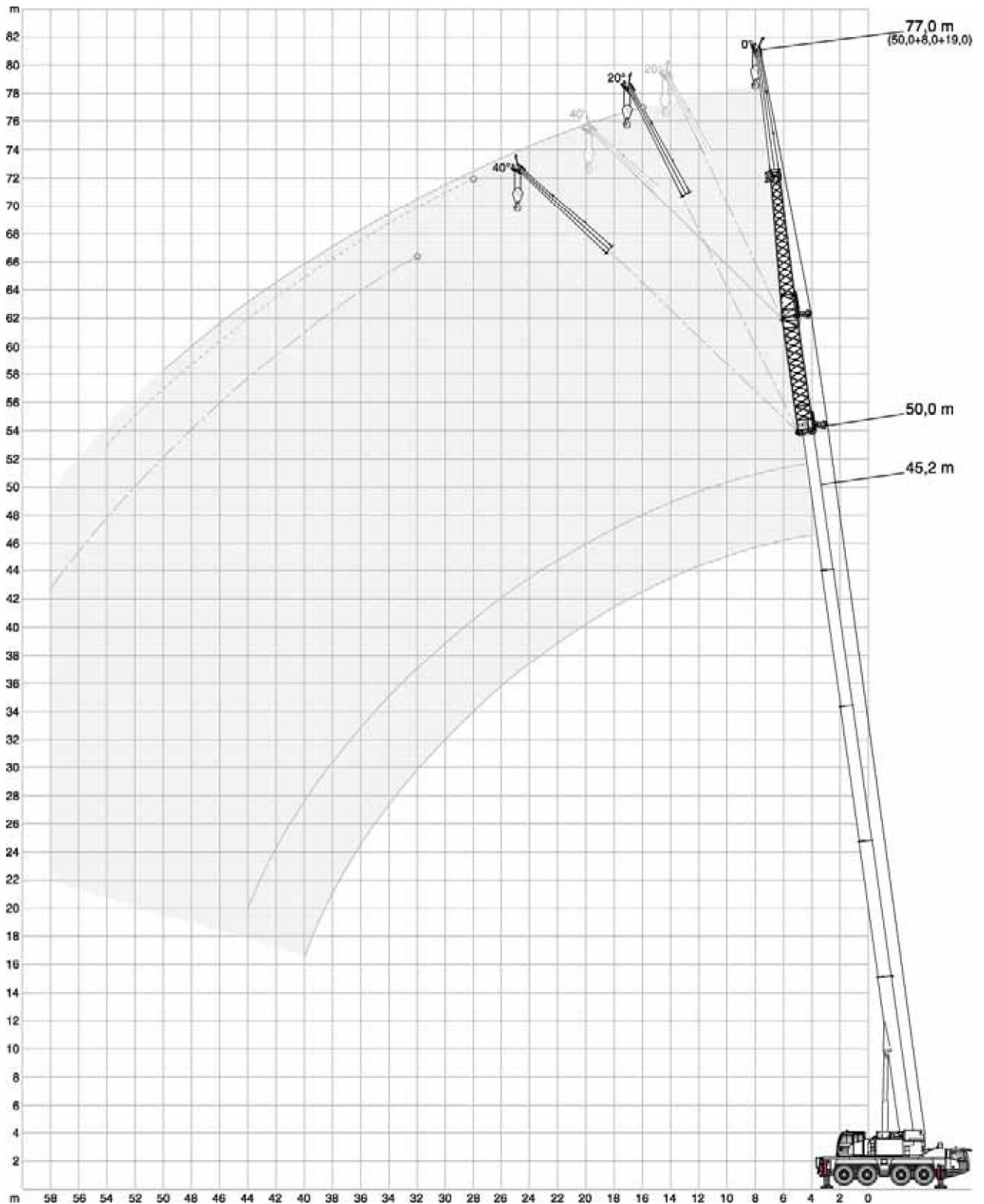
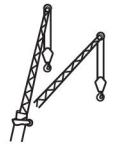

m	10,1 m			19,0 m		
	0°	20°	40°	0°	20°	40°
12	6,3	-	-	-	-	-
14	6,3	-	-	3,5	-	-
16	5,6	6,3	-	3,5	-	-
18	4,9	5,5	-	3,5	-	-
20	4,4	4,6	5,2	3,2	-	-
22	3,5	4,1	4,3	2,8	3,4	-
24	2,8	3,3	3,7	2,6	3,0	-
26	2,2	2,7	3,1	2,0	2,6	-
28	1,7	2,2	2,5	1,5	2,4	2,8
30	1,3	1,7	2,0	1,2	1,9	2,3
32	1,0	1,3	1,6	0,8	1,5	2,1
34	-	1,0	1,2	-	1,1	1,7
36	-	-	0,9	-	0,8	1,3
38	-	-	-	-	-	1,0
40	-	-	-	-	-	0,7



 12,0 m

m	10,1 m			19,0 m		
	0°	20°	40°	0°	20°	40°
3	13,4	-	-	8,7	-	-
4	13,4	-	-	8,6	-	-
5	13,4	13,4	-	8,4	-	-
6	13,4	12,8	-	8,3	-	-
7	13,3	12,0	-	8,0	-	-
8	12,9	11,4	9,4	7,8	-	-
9	12,5	10,8	9,0	7,6	-	-
10	12,1	10,2	8,7	7,3	6,4	-
12	11,0	9,3	8,1	6,8	5,9	-
14	9,8	8,5	7,7	6,2	5,4	-
16	8,6	7,9	7,5	5,7	5,0	4,3
18	7,0	7,2	-	5,3	4,7	4,1
20	-	-	-	4,9	4,4	3,9
22	-	-	-	4,5	4,1	3,7
24	-	-	-	4,2	3,9	3,7
26	-	-	-	3,9	3,8	-



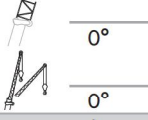
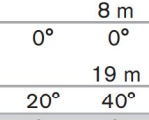

25,2 t			8,10 m x 7,20 m					360°					ISO
 50,0 m			 45,2 m					 41,8 m					
													
m	t	t	m	t	t	t	t	m	t	t	t	t	t
16	2,2	-	14	3,0	-	-	-	14	4,0	-	-	-	-
18	2,2	-	16	3,0	-	-	-	16	3,9	-	-	-	-
20	2,2	-	18	3,0	-	-	-	18	3,8	-	-	-	-
22	2,2	-	20	3,0	-	-	-	20	3,7	3,4	-	-	-
24	2,2	2,1	22	3,0	2,9	-	-	22	3,6	3,2	-	-	-
26	2,2	2,1	24	3,0	2,8	-	-	24	3,4	3,1	-	2,8	-
28	2,2	2,1	26	2,9	2,8	-	2,5	26	3,3	3,0	2,8	2,7	-
30	2,2	2,1	28	2,8	2,7	2,5	2,4	28	3,1	2,8	2,7	2,6	-
32	2,2	2,1	30	2,7	2,6	2,5	2,3	30	3,0	2,7	2,6	2,5	2,0
34	2,2	2,1	32	2,6	2,5	2,4	2,2	32	2,9	2,6	2,5	2,4	2,0
36	2,2	2,0	34	2,6	2,4	2,3	2,2	34	2,8	2,5	2,4	2,3	1,9
38	2,2	2,0	36	2,5	2,3	2,3	2,1	36	2,6	2,4	2,3	2,2	1,9
40	2,1	1,9	38	2,4	2,2	2,2	2,0	38	2,5	2,3	2,3	2,1	1,8
42	1,9	1,8	40	2,3	2,2	2,1	2,0	40	2,4	2,3	2,2	2,0	1,8
44	1,6	1,8	42	2,0	2,1	2,1	1,9	42	2,3	2,2	2,1	2,0	1,7
46	1,3	1,7	44	1,8	2,0	2,0	1,9	44	2,0	2,1	2,1	1,9	1,7
48	1,0	1,4	46	1,6	1,8	2,0	1,8	46	1,7	2,0	2,0	1,9	1,7
50	0,8	1,2	48	1,4	1,6	1,8	1,6	48	1,4	1,8	2,0	1,8	1,7
52	-	0,9	50	1,1	1,4	1,5	1,4	50	1,2	1,5	1,7	1,6	1,6
			52	0,9	1,2	1,2	1,1	52	1,0	1,2	1,4	1,3	1,3
			54	-	1,0	0,9	0,9	54	0,8	1,0	1,1	1,1	1,0
			56	-	0,7	-	-	56	-	0,8	0,9	0,9	0,8

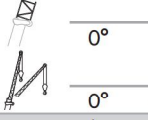
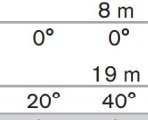

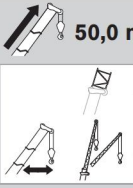
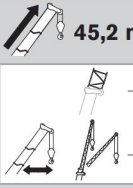
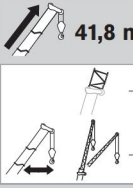
 37,5 m			8 m					19 m				
												
m	t	t	t	t	t	t	m	t	t	t	t	t
12	4,8	-	-	-	-	-	12	4,8	-	-	-	-
14	4,6	-	-	-	-	-	14	4,6	-	-	-	-
16	4,4	-	-	-	-	-	16	4,4	-	-	-	-
18	4,2	-	-	-	-	-	18	4,2	-	-	-	-
20	4,0	3,6	-	-	-	-	20	4,0	3,6	-	-	-
22	3,8	3,4	-	3,1	-	-	22	3,8	3,4	-	3,1	-
24	3,6	3,2	3,0	2,9	-	-	24	3,6	3,2	3,0	2,9	-
26	3,4	3,1	2,9	2,8	-	-	26	3,4	3,1	2,9	2,8	-
28	3,2	3,0	2,7	2,7	2,2	-	28	3,2	3,0	2,7	2,7	2,2
30	3,1	2,8	2,6	2,6	2,1	-	30	3,1	2,8	2,6	2,6	2,1
32	3,0	2,7	2,6	2,4	2,0	-	32	3,0	2,7	2,6	2,4	2,0
34	2,8	2,6	2,5	2,3	2,0	-	34	2,8	2,6	2,5	2,3	2,0
36	2,7	2,5	2,4	2,2	1,9	-	36	2,7	2,5	2,4	2,2	1,9
38	2,6	2,4	2,3	2,2	1,9	-	38	2,6	2,4	2,3	2,2	1,9
40	2,4	2,3	2,2	2,1	1,8	-	40	2,4	2,3	2,2	2,1	1,8
42	2,3	2,2	2,2	2,0	1,8	-	42	2,3	2,2	2,2	2,0	1,8
44	2,2	2,1	2,1	1,9	1,8	-	44	2,2	2,1	2,1	1,9	1,8
46	1,9	2,0	2,1	1,9	1,7	-	46	1,9	2,0	2,1	1,9	1,7
48	1,8	1,9	2,0	1,8	1,7	-	48	1,8	1,9	2,0	1,8	1,7
50	1,6	1,7	1,8	1,8	1,7	-	50	1,6	1,7	1,8	1,8	1,7
52	1,4	1,6	1,7	1,6	1,5	-	52	1,4	1,6	1,7	1,6	1,5
54	1,2	1,3	-	1,4	1,2	-	54	1,2	1,3	-	1,4	1,2
56	1,0	1,1	-	1,2	-	-	56	1,0	1,1	-	1,2	-
58	0,8	0,9	-	1,0	-	-	58	0,8	0,9	-	1,0	-

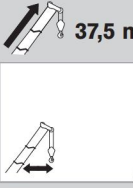

 11,9 m			8 m					19 m				
												
m	t	t	t	t	t	t	m	t	t	t	t	t
5	7,4	-	-	-	-	-	5	7,4	-	-	-	-
6	7,3	-	-	-	-	-	6	7,3	-	-	-	-
7	7,0	-	-	-	-	-	7	7,0	-	-	-	-
8	6,7	-	-	-	-	-	8	6,7	-	-	-	-
9	6,4	-	-	-	-	-	9	6,4	-	-	-	-
10	6,1	-	-	-	-	-	10	6,1	-	-	-	-
12	5,5	4,9	-	-	-	-	12	5,5	4,9	-	-	-
14	4,9	4,5	-	4,1	-	-	14	4,9	4,5	-	4,1	-
16	4,5	4,1	-	3,8	-	-	16	4,5	4,1	-	3,8	-
18	4,1	3,7	3,5	3,4	-	-	18	4,1	3,7	3,5	3,4	-
20	3,7	3,4	3,2	3,2	-	-	20	3,7	3,4	3,2	3,2	-
22	3,3	3,2	3,0	2,9	2,5	-	22	3,3	3,2	3,0	2,9	2,5
24	3,1	2,9	2,8	2,7	2,4	-	24	3,1	2,9	2,8	2,7	2,4
26	2,8	2,7	2,7	2,5	2,2	-	26	2,8	2,7	2,7	2,5	2,2
28	2,6	2,5	2,5	2,3	2,1	-	28	2,6	2,5	2,5	2,3	2,1
30	2,4	2,3	2,4	2,2	2,0	-	30	2,4	2,3	2,4	2,2	2,0
32	2,2	2,2	-	2,1	2,0	-	32	2,2	2,2	-	2,1	2,0
34	2,1	2,1	-	2,0	-	-	34	2,1	2,1	-	2,0	-

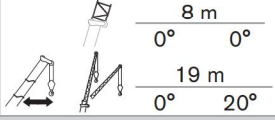
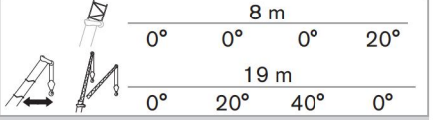
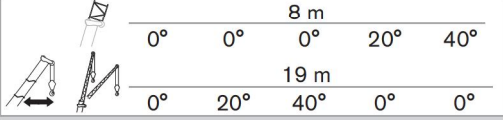

20,2 t			8,10 m x 7,20 m					360°					ISO																																																																																																																																																																																																																																																																																																																																																																																																							
50,0 m			45,2 m					41,8 m																																																																																																																																																																																																																																																																																																																																																																																																												
																																																																																																																																																																																																																																																																																																																																																																																																																				
<table border="1"> <thead> <tr> <th colspan="2"></th> <th colspan="2">8 m</th> </tr> <tr> <th colspan="2"></th> <th>0°</th> <th>0°</th> </tr> </thead> <tbody> <tr> <td colspan="2">19 m</td> <td>0°</td> <td>20°</td> </tr> <tr> <th>m</th> <th>t</th> <th>t</th> <th>t</th> </tr> <tr><td>16</td><td>2,2</td><td>-</td><td>-</td></tr> <tr><td>18</td><td>2,2</td><td>-</td><td>-</td></tr> <tr><td>20</td><td>2,2</td><td>-</td><td>-</td></tr> <tr><td>22</td><td>2,2</td><td>-</td><td>-</td></tr> <tr><td>24</td><td>2,2</td><td>2,1</td><td>-</td></tr> <tr><td>26</td><td>2,2</td><td>2,1</td><td>-</td></tr> <tr><td>28</td><td>2,2</td><td>2,1</td><td>-</td></tr> <tr><td>30</td><td>2,2</td><td>2,1</td><td>-</td></tr> <tr><td>32</td><td>2,2</td><td>2,1</td><td>-</td></tr> <tr><td>34</td><td>2,2</td><td>2,1</td><td>-</td></tr> <tr><td>36</td><td>2,1</td><td>2,0</td><td>-</td></tr> <tr><td>38</td><td>1,7</td><td>2,0</td><td>-</td></tr> <tr><td>40</td><td>1,4</td><td>1,9</td><td>-</td></tr> <tr><td>42</td><td>1,1</td><td>1,6</td><td>-</td></tr> <tr><td>44</td><td>0,9</td><td>1,3</td><td>-</td></tr> <tr><td>46</td><td>-</td><td>1,1</td><td>-</td></tr> <tr><td>48</td><td>-</td><td>0,8</td><td>-</td></tr> </tbody> </table>					8 m				0°	0°	19 m		0°	20°	m	t	t	t	16	2,2	-	-	18	2,2	-	-	20	2,2	-	-	22	2,2	-	-	24	2,2	2,1	-	26	2,2	2,1	-	28	2,2	2,1	-	30	2,2	2,1	-	32	2,2	2,1	-	34	2,2	2,1	-	36	2,1	2,0	-	38	1,7	2,0	-	40	1,4	1,9	-	42	1,1	1,6	-	44	0,9	1,3	-	46	-	1,1	-	48	-	0,8	-	<table border="1"> <thead> <tr> <th colspan="2"></th> <th colspan="4">8 m</th> </tr> <tr> <th colspan="2"></th> <th>0°</th> <th>0°</th> <th>0°</th> <th>20°</th> </tr> </thead> <tbody> <tr> <td colspan="2">19 m</td> <th>0°</th> <th>20°</th> <th>40°</th> <th>0°</th> </tr> <tr> <th>m</th> <th>t</th> <th>t</th> <th>t</th> <th>t</th> <th>t</th> </tr> <tr><td>14</td><td>3,0</td><td>-</td><td>-</td><td>-</td><td>-</td></tr> <tr><td>16</td><td>3,0</td><td>-</td><td>-</td><td>-</td><td>-</td></tr> <tr><td>18</td><td>3,0</td><td>-</td><td>-</td><td>-</td><td>-</td></tr> <tr><td>20</td><td>3,0</td><td>-</td><td>-</td><td>-</td><td>-</td></tr> <tr><td>22</td><td>3,0</td><td>2,9</td><td>-</td><td>-</td><td>-</td></tr> <tr><td>24</td><td>3,0</td><td>2,8</td><td>-</td><td>-</td><td>-</td></tr> <tr><td>26</td><td>2,9</td><td>2,8</td><td>-</td><td>2,5</td><td>-</td></tr> <tr><td>28</td><td>2,8</td><td>2,7</td><td>2,5</td><td>2,4</td><td>-</td></tr> <tr><td>30</td><td>2,7</td><td>2,6</td><td>2,5</td><td>2,3</td><td>-</td></tr> <tr><td>32</td><td>2,6</td><td>2,5</td><td>2,4</td><td>2,2</td><td>-</td></tr> <tr><td>34</td><td>2,6</td><td>2,4</td><td>2,3</td><td>2,2</td><td>-</td></tr> <tr><td>36</td><td>2,4</td><td>2,3</td><td>2,3</td><td>2,1</td><td>-</td></tr> <tr><td>38</td><td>2,2</td><td>2,2</td><td>2,2</td><td>2,0</td><td>-</td></tr> <tr><td>40</td><td>1,9</td><td>2,2</td><td>2,1</td><td>2,0</td><td>-</td></tr> <tr><td>42</td><td>1,6</td><td>1,9</td><td>2,1</td><td>1,9</td><td>-</td></tr> <tr><td>44</td><td>1,3</td><td>1,7</td><td>1,9</td><td>1,7</td><td>-</td></tr> <tr><td>46</td><td>1,0</td><td>1,4</td><td>1,5</td><td>1,4</td><td>-</td></tr> <tr><td>48</td><td>0,8</td><td>1,1</td><td>1,2</td><td>1,1</td><td>-</td></tr> <tr><td>50</td><td>-</td><td>0,9</td><td>0,9</td><td>0,8</td><td>-</td></tr> </tbody> </table>							8 m						0°	0°	0°	20°	19 m		0°	20°	40°	0°	m	t	t	t	t	t	14	3,0	-	-	-	-	16	3,0	-	-	-	-	18	3,0	-	-	-	-	20	3,0	-	-	-	-	22	3,0	2,9	-	-	-	24	3,0	2,8	-	-	-	26	2,9	2,8	-	2,5	-	28	2,8	2,7	2,5	2,4	-	30	2,7	2,6	2,5	2,3	-	32	2,6	2,5	2,4	2,2	-	34	2,6	2,4	2,3	2,2	-	36	2,4	2,3	2,3	2,1	-	38	2,2	2,2	2,2	2,0	-	40	1,9	2,2	2,1	2,0	-	42	1,6	1,9	2,1	1,9	-	44	1,3	1,7	1,9	1,7	-	46	1,0	1,4	1,5	1,4	-	48	0,8	1,1	1,2	1,1	-	50	-	0,9	0,9	0,8	-	<table border="1"> <thead> <tr> <th colspan="2"></th> <th colspan="5">8 m</th> </tr> <tr> <th colspan="2"></th> <th>0°</th> <th>0°</th> <th>0°</th> <th>20°</th> <th>40°</th> </tr> </thead> <tbody> <tr> <td colspan="2">19 m</td> <th>0°</th> <th>20°</th> <th>40°</th> <th>0°</th> <th>0°</th> </tr> <tr> <th>m</th> <th>t</th> <th>t</th> <th>t</th> <th>t</th> <th>t</th> <th>t</th> </tr> <tr><td>14</td><td>4,0</td><td>-</td><td>-</td><td>-</td><td>-</td><td>-</td></tr> <tr><td>16</td><td>3,9</td><td>-</td><td>-</td><td>-</td><td>-</td><td>-</td></tr> <tr><td>18</td><td>3,8</td><td>-</td><td>-</td><td>-</td><td>-</td><td>-</td></tr> <tr><td>20</td><td>3,7</td><td>3,4</td><td>-</td><td>-</td><td>-</td><td>-</td></tr> <tr><td>22</td><td>3,6</td><td>3,2</td><td>-</td><td>-</td><td>-</td><td>-</td></tr> <tr><td>24</td><td>3,4</td><td>3,1</td><td>-</td><td>2,8</td><td>-</td><td>-</td></tr> <tr><td>26</td><td>3,3</td><td>3,0</td><td>2,8</td><td>2,7</td><td>-</td><td>-</td></tr> <tr><td>28</td><td>3,1</td><td>2,8</td><td>2,7</td><td>2,6</td><td>-</td><td>-</td></tr> <tr><td>30</td><td>3,0</td><td>2,7</td><td>2,6</td><td>2,5</td><td>2,0</td><td>-</td></tr> <tr><td>32</td><td>2,9</td><td>2,6</td><td>2,5</td><td>2,4</td><td>2,0</td><td>-</td></tr> <tr><td>34</td><td>2,8</td><td>2,5</td><td>2,4</td><td>2,3</td><td>1,9</td><td>-</td></tr> <tr><td>36</td><td>2,6</td><td>2,4</td><td>2,3</td><td>2,2</td><td>1,9</td><td>-</td></tr> <tr><td>38</td><td>2,4</td><td>2,3</td><td>2,3</td><td>2,1</td><td>1,8</td><td>-</td></tr> <tr><td>40</td><td>2,0</td><td>2,2</td><td>2,2</td><td>2,0</td><td>1,8</td><td>-</td></tr> <tr><td>42</td><td>1,7</td><td>2,1</td><td>2,1</td><td>2,0</td><td>1,7</td><td>-</td></tr> <tr><td>44</td><td>1,4</td><td>1,8</td><td>2,1</td><td>1,9</td><td>1,7</td><td>-</td></tr> <tr><td>46</td><td>1,1</td><td>1,5</td><td>1,7</td><td>1,6</td><td>1,7</td><td>-</td></tr> <tr><td>48</td><td>0,9</td><td>1,2</td><td>1,4</td><td>1,3</td><td>1,4</td><td>-</td></tr> <tr><td>50</td><td>-</td><td>0,9</td><td>1,1</td><td>1,0</td><td>1,1</td><td>-</td></tr> <tr><td>52</td><td>-</td><td>0,7</td><td>0,9</td><td>0,8</td><td>0,8</td><td>-</td></tr> </tbody> </table>							8 m							0°	0°	0°	20°	40°	19 m		0°	20°	40°	0°	0°	m	t	t	t	t	t	t	14	4,0	-	-	-	-	-	16	3,9	-	-	-	-	-	18	3,8	-	-	-	-	-	20	3,7	3,4	-	-	-	-	22	3,6	3,2	-	-	-	-	24	3,4	3,1	-	2,8	-	-	26	3,3	3,0	2,8	2,7	-	-	28	3,1	2,8	2,7	2,6	-	-	30	3,0	2,7	2,6	2,5	2,0	-	32	2,9	2,6	2,5	2,4	2,0	-	34	2,8	2,5	2,4	2,3	1,9	-	36	2,6	2,4	2,3	2,2	1,9	-	38	2,4	2,3	2,3	2,1	1,8	-	40	2,0	2,2	2,2	2,0	1,8	-	42	1,7	2,1	2,1	2,0	1,7	-	44	1,4	1,8	2,1	1,9	1,7	-	46	1,1	1,5	1,7	1,6	1,7	-	48	0,9	1,2	1,4	1,3	1,4	-	50	-	0,9	1,1	1,0	1,1	-	52	-	0,7	0,9	0,8	0,8	-		
		8 m																																																																																																																																																																																																																																																																																																																																																																																																																		
		0°	0°																																																																																																																																																																																																																																																																																																																																																																																																																	
19 m		0°	20°																																																																																																																																																																																																																																																																																																																																																																																																																	
m	t	t	t																																																																																																																																																																																																																																																																																																																																																																																																																	
16	2,2	-	-																																																																																																																																																																																																																																																																																																																																																																																																																	
18	2,2	-	-																																																																																																																																																																																																																																																																																																																																																																																																																	
20	2,2	-	-																																																																																																																																																																																																																																																																																																																																																																																																																	
22	2,2	-	-																																																																																																																																																																																																																																																																																																																																																																																																																	
24	2,2	2,1	-																																																																																																																																																																																																																																																																																																																																																																																																																	
26	2,2	2,1	-																																																																																																																																																																																																																																																																																																																																																																																																																	
28	2,2	2,1	-																																																																																																																																																																																																																																																																																																																																																																																																																	
30	2,2	2,1	-																																																																																																																																																																																																																																																																																																																																																																																																																	
32	2,2	2,1	-																																																																																																																																																																																																																																																																																																																																																																																																																	
34	2,2	2,1	-																																																																																																																																																																																																																																																																																																																																																																																																																	
36	2,1	2,0	-																																																																																																																																																																																																																																																																																																																																																																																																																	
38	1,7	2,0	-																																																																																																																																																																																																																																																																																																																																																																																																																	
40	1,4	1,9	-																																																																																																																																																																																																																																																																																																																																																																																																																	
42	1,1	1,6	-																																																																																																																																																																																																																																																																																																																																																																																																																	
44	0,9	1,3	-																																																																																																																																																																																																																																																																																																																																																																																																																	
46	-	1,1	-																																																																																																																																																																																																																																																																																																																																																																																																																	
48	-	0,8	-																																																																																																																																																																																																																																																																																																																																																																																																																	
		8 m																																																																																																																																																																																																																																																																																																																																																																																																																		
		0°	0°	0°	20°																																																																																																																																																																																																																																																																																																																																																																																																															
19 m		0°	20°	40°	0°																																																																																																																																																																																																																																																																																																																																																																																																															
m	t	t	t	t	t																																																																																																																																																																																																																																																																																																																																																																																																															
14	3,0	-	-	-	-																																																																																																																																																																																																																																																																																																																																																																																																															
16	3,0	-	-	-	-																																																																																																																																																																																																																																																																																																																																																																																																															
18	3,0	-	-	-	-																																																																																																																																																																																																																																																																																																																																																																																																															
20	3,0	-	-	-	-																																																																																																																																																																																																																																																																																																																																																																																																															
22	3,0	2,9	-	-	-																																																																																																																																																																																																																																																																																																																																																																																																															
24	3,0	2,8	-	-	-																																																																																																																																																																																																																																																																																																																																																																																																															
26	2,9	2,8	-	2,5	-																																																																																																																																																																																																																																																																																																																																																																																																															
28	2,8	2,7	2,5	2,4	-																																																																																																																																																																																																																																																																																																																																																																																																															
30	2,7	2,6	2,5	2,3	-																																																																																																																																																																																																																																																																																																																																																																																																															
32	2,6	2,5	2,4	2,2	-																																																																																																																																																																																																																																																																																																																																																																																																															
34	2,6	2,4	2,3	2,2	-																																																																																																																																																																																																																																																																																																																																																																																																															
36	2,4	2,3	2,3	2,1	-																																																																																																																																																																																																																																																																																																																																																																																																															
38	2,2	2,2	2,2	2,0	-																																																																																																																																																																																																																																																																																																																																																																																																															
40	1,9	2,2	2,1	2,0	-																																																																																																																																																																																																																																																																																																																																																																																																															
42	1,6	1,9	2,1	1,9	-																																																																																																																																																																																																																																																																																																																																																																																																															
44	1,3	1,7	1,9	1,7	-																																																																																																																																																																																																																																																																																																																																																																																																															
46	1,0	1,4	1,5	1,4	-																																																																																																																																																																																																																																																																																																																																																																																																															
48	0,8	1,1	1,2	1,1	-																																																																																																																																																																																																																																																																																																																																																																																																															
50	-	0,9	0,9	0,8	-																																																																																																																																																																																																																																																																																																																																																																																																															
		8 m																																																																																																																																																																																																																																																																																																																																																																																																																		
		0°	0°	0°	20°	40°																																																																																																																																																																																																																																																																																																																																																																																																														
19 m		0°	20°	40°	0°	0°																																																																																																																																																																																																																																																																																																																																																																																																														
m	t	t	t	t	t	t																																																																																																																																																																																																																																																																																																																																																																																																														
14	4,0	-	-	-	-	-																																																																																																																																																																																																																																																																																																																																																																																																														
16	3,9	-	-	-	-	-																																																																																																																																																																																																																																																																																																																																																																																																														
18	3,8	-	-	-	-	-																																																																																																																																																																																																																																																																																																																																																																																																														
20	3,7	3,4	-	-	-	-																																																																																																																																																																																																																																																																																																																																																																																																														
22	3,6	3,2	-	-	-	-																																																																																																																																																																																																																																																																																																																																																																																																														
24	3,4	3,1	-	2,8	-	-																																																																																																																																																																																																																																																																																																																																																																																																														
26	3,3	3,0	2,8	2,7	-	-																																																																																																																																																																																																																																																																																																																																																																																																														
28	3,1	2,8	2,7	2,6	-	-																																																																																																																																																																																																																																																																																																																																																																																																														
30	3,0	2,7	2,6	2,5	2,0	-																																																																																																																																																																																																																																																																																																																																																																																																														
32	2,9	2,6	2,5	2,4	2,0	-																																																																																																																																																																																																																																																																																																																																																																																																														
34	2,8	2,5	2,4	2,3	1,9	-																																																																																																																																																																																																																																																																																																																																																																																																														
36	2,6	2,4	2,3	2,2	1,9	-																																																																																																																																																																																																																																																																																																																																																																																																														
38	2,4	2,3	2,3	2,1	1,8	-																																																																																																																																																																																																																																																																																																																																																																																																														
40	2,0	2,2	2,2	2,0	1,8	-																																																																																																																																																																																																																																																																																																																																																																																																														
42	1,7	2,1	2,1	2,0	1,7	-																																																																																																																																																																																																																																																																																																																																																																																																														
44	1,4	1,8	2,1	1,9	1,7	-																																																																																																																																																																																																																																																																																																																																																																																																														
46	1,1	1,5	1,7	1,6	1,7	-																																																																																																																																																																																																																																																																																																																																																																																																														
48	0,9	1,2	1,4	1,3	1,4	-																																																																																																																																																																																																																																																																																																																																																																																																														
50	-	0,9	1,1	1,0	1,1	-																																																																																																																																																																																																																																																																																																																																																																																																														
52	-	0,7	0,9	0,8	0,8	-																																																																																																																																																																																																																																																																																																																																																																																																														

37,5 m																																																																																																																																																																																												
																																																																																																																																																																																												
<table border="1"> <thead> <tr> <th colspan="2"></th> <th colspan="5">8 m</th> </tr> <tr> <th colspan="2"></th> <th>0°</th> <th>0°</th> <th>0°</th> <th>20°</th> <th>40°</th> </tr> </thead> <tbody> <tr> <td colspan="2">19 m</td> <th>0°</th> <th>20°</th> <th>40°</th> <th>0°</th> <th>0°</th> </tr> <tr> <th>m</th> <th>t</th> <th>t</th> <th>t</th> <th>t</th> <th>t</th> <th>t</th> </tr> <tr><td>12</td><td>4,8</td><td>-</td><td>-</td><td>-</td><td>-</td><td>-</td></tr> <tr><td>14</td><td>4,6</td><td>-</td><td>-</td><td>-</td><td>-</td><td>-</td></tr> <tr><td>16</td><td>4,4</td><td>-</td><td>-</td><td>-</td><td>-</td><td>-</td></tr> <tr><td>18</td><td>4,2</td><td>-</td><td>-</td><td>-</td><td>-</td><td>-</td></tr> <tr><td>20</td><td>4,0</td><td>3,6</td><td>-</td><td>-</td><td>-</td><td>-</td></tr> <tr><td>22</td><td>3,8</td><td>3,4</td><td>-</td><td>3,1</td><td>-</td><td>-</td></tr> <tr><td>24</td><td>3,6</td><td>3,2</td><td>3,0</td><td>2,9</td><td>-</td><td>-</td></tr> <tr><td>26</td><td>3,4</td><td>3,1</td><td>2,9</td><td>2,8</td><td>-</td><td>-</td></tr> <tr><td>28</td><td>3,2</td><td>3,0</td><td>2,7</td><td>2,7</td><td>2,2</td><td>-</td></tr> <tr><td>30</td><td>3,1</td><td>2,8</td><td>2,6</td><td>2,6</td><td>2,1</td><td>-</td></tr> <tr><td>32</td><td>3,0</td><td>2,7</td><td>2,6</td><td>2,4</td><td>2,0</td><td>-</td></tr> <tr><td>34</td><td>2,8</td><td>2,6</td><td>2,5</td><td>2,3</td><td>2,0</td><td>-</td></tr> <tr><td>36</td><td>2,7</td><td>2,5</td><td>2,4</td><td>2,2</td><td>1,9</td><td>-</td></tr> <tr><td>38</td><td>2,5</td><td>2,4</td><td>2,3</td><td>2,2</td><td>1,9</td><td>-</td></tr> <tr><td>40</td><td>2,3</td><td>2,3</td><td>2,2</td><td>2,1</td><td>1,8</td><td>-</td></tr> <tr><td>42</td><td>2,1</td><td>2,2</td><td>2,2</td><td>2,0</td><td>1,8</td><td>-</td></tr> <tr><td>44</td><td>1,8</td><td>2,0</td><td>2,1</td><td>1,9</td><td>1,8</td><td>-</td></tr> <tr><td>46</td><td>1,5</td><td>1,8</td><td>2,0</td><td>1,8</td><td>1,7</td><td>-</td></tr> <tr><td>48</td><td>1,3</td><td>1,5</td><td>1,7</td><td>1,6</td><td>1,6</td><td>-</td></tr> <tr><td>50</td><td>1,0</td><td>1,3</td><td>1,4</td><td>1,4</td><td>1,3</td><td>-</td></tr> <tr><td>52</td><td>0,8</td><td>1,1</td><td>1,2</td><td>1,1</td><td>1,0</td><td>-</td></tr> <tr><td>54</td><td>-</td><td>0,8</td><td>-</td><td>0,9</td><td>-</td><td>-</td></tr> </tbody> </table>									8 m							0°	0°	0°	20°	40°	19 m		0°	20°	40°	0°	0°	m	t	t	t	t	t	t	12	4,8	-	-	-	-	-	14	4,6	-	-	-	-	-	16	4,4	-	-	-	-	-	18	4,2	-	-	-	-	-	20	4,0	3,6	-	-	-	-	22	3,8	3,4	-	3,1	-	-	24	3,6	3,2	3,0	2,9	-	-	26	3,4	3,1	2,9	2,8	-	-	28	3,2	3,0	2,7	2,7	2,2	-	30	3,1	2,8	2,6	2,6	2,1	-	32	3,0	2,7	2,6	2,4	2,0	-	34	2,8	2,6	2,5	2,3	2,0	-	36	2,7	2,5	2,4	2,2	1,9	-	38	2,5	2,4	2,3	2,2	1,9	-	40	2,3	2,3	2,2	2,1	1,8	-	42	2,1	2,2	2,2	2,0	1,8	-	44	1,8	2,0	2,1	1,9	1,8	-	46	1,5	1,8	2,0	1,8	1,7	-	48	1,3	1,5	1,7	1,6	1,6	-	50	1,0	1,3	1,4	1,4	1,3	-	52	0,8	1,1	1,2	1,1	1,0	-	54	-	0,8	-	0,9	-	-
		8 m																																																																																																																																																																																										
		0°	0°	0°	20°	40°																																																																																																																																																																																						
19 m		0°	20°	40°	0°	0°																																																																																																																																																																																						
m	t	t	t	t	t	t																																																																																																																																																																																						
12	4,8	-	-	-	-	-																																																																																																																																																																																						
14	4,6	-	-	-	-	-																																																																																																																																																																																						
16	4,4	-	-	-	-	-																																																																																																																																																																																						
18	4,2	-	-	-	-	-																																																																																																																																																																																						
20	4,0	3,6	-	-	-	-																																																																																																																																																																																						
22	3,8	3,4	-	3,1	-	-																																																																																																																																																																																						
24	3,6	3,2	3,0	2,9	-	-																																																																																																																																																																																						
26	3,4	3,1	2,9	2,8	-	-																																																																																																																																																																																						
28	3,2	3,0	2,7	2,7	2,2	-																																																																																																																																																																																						
30	3,1	2,8	2,6	2,6	2,1	-																																																																																																																																																																																						
32	3,0	2,7	2,6	2,4	2,0	-																																																																																																																																																																																						
34	2,8	2,6	2,5	2,3	2,0	-																																																																																																																																																																																						
36	2,7	2,5	2,4	2,2	1,9	-																																																																																																																																																																																						
38	2,5	2,4	2,3	2,2	1,9	-																																																																																																																																																																																						
40	2,3	2,3	2,2	2,1	1,8	-																																																																																																																																																																																						
42	2,1	2,2	2,2	2,0	1,8	-																																																																																																																																																																																						
44	1,8	2,0	2,1	1,9	1,8	-																																																																																																																																																																																						
46	1,5	1,8	2,0	1,8	1,7	-																																																																																																																																																																																						
48	1,3	1,5	1,7	1,6	1,6	-																																																																																																																																																																																						
50	1,0	1,3	1,4	1,4	1,3	-																																																																																																																																																																																						
52	0,8	1,1	1,2	1,1	1,0	-																																																																																																																																																																																						
54	-	0,8	-	0,9	-	-																																																																																																																																																																																						

11,9 m																																																																																																																																																														
																																																																																																																																																														
<table border="1"> <thead> <tr> <th colspan="2"></th> <th colspan="4">8 m</th> </tr> <tr> <th colspan="2"></th> <th>0°</th> <th>0°</th> <th>0°</th> <th>20°</th> <th>40°</th> </tr> </thead> <tbody> <tr> <td colspan="2">19 m</td> <th>0°</th> <th>20°</th> <th>40°</th> <th>0°</th> <th>0°</th> </tr> <tr> <th>m</th> <th>t</th> <th>t</th> <th>t</th> <th>t</th> <th>t</th> <th>t</th> </tr> <tr><td>5</td><td>7,4</td><td>-</td><td>-</td><td>-</td><td>-</td><td>-</td></tr> <tr><td>6</td><td>7,3</td><td>-</td><td>-</td><td>-</td><td>-</td><td>-</td></tr> <tr><td>7</td><td>7,0</td><td>-</td><td>-</td><td>-</td><td>-</td><td>-</td></tr> <tr><td>8</td><td>6,7</td><td>-</td><td>-</td><td>-</td><td>-</td><td>-</td></tr> <tr><td>9</td><td>6,4</td><td>-</td><td>-</td><td>-</td><td>-</td><td>-</td></tr> <tr><td>10</td><td>6,1</td><td>-</td><td>-</td><td>-</td><td>-</td><td>-</td></tr> <tr><td>12</td><td>5,5</td><td>4,9</td><td>-</td><td>-</td><td>-</td><td>-</td></tr> <tr><td>14</td><td>4,9</td><td>4,5</td><td>-</td><td>4,1</td><td>-</td><td>-</td></tr> <tr><td>16</td><td>4,5</td><td>4,1</td><td>-</td><td>3,8</td><td>-</td><td>-</td></tr> <tr><td>18</td><td>4,1</td><td>3,7</td><td>3,5</td><td>3,4</td><td>-</td><td>-</td></tr> <tr><td>20</td><td>3,7</td><td>3,4</td><td>3,2</td><td>3,2</td><td>-</td><td>-</td></tr> <tr><td>22</td><td>3,3</td><td>3,2</td><td>3,0</td><td>2,9</td><td>2,5</td><td>-</td></tr> <tr><td>24</td><td>3,1</td><td>2,9</td><td>2,8</td><td>2,7</td><td>2,4</td><td>-</td></tr> <tr><td>26</td><td>2,8</td><td>2,7</td><td>2,7</td><td>2,5</td><td>2,2</td><td>-</td></tr> <tr><td>28</td><td>2,6</td><td>2,5</td><td>2,5</td><td>2,3</td><td>2,1</td><td>-</td></tr> <tr><td>30</td><td>2,4</td><td>2,3</td><td>2,4</td><td>2,2</td><td>2,0</td><td>-</td></tr> <tr><td>32</td><td>2,2</td><td>2,2</td><td>-</td><td>2,1</td><td>2,0</td><td>-</td></tr> <tr><td>34</td><td>2,1</td><td>2,1</td><td>-</td><td>2,0</td><td>-</td><td>-</td></tr> </tbody> </table>								8 m						0°	0°	0°	20°	40°	19 m		0°	20°	40°	0°	0°	m	t	t	t	t	t	t	5	7,4	-	-	-	-	-	6	7,3	-	-	-	-	-	7	7,0	-	-	-	-	-	8	6,7	-	-	-	-	-	9	6,4	-	-	-	-	-	10	6,1	-	-	-	-	-	12	5,5	4,9	-	-	-	-	14	4,9	4,5	-	4,1	-	-	16	4,5	4,1	-	3,8	-	-	18	4,1	3,7	3,5	3,4	-	-	20	3,7	3,4	3,2	3,2	-	-	22	3,3	3,2	3,0	2,9	2,5	-	24	3,1	2,9	2,8	2,7	2,4	-	26	2,8	2,7	2,7	2,5	2,2	-	28	2,6	2,5	2,5	2,3	2,1	-	30	2,4	2,3	2,4	2,2	2,0	-	32	2,2	2,2	-	2,1	2,0	-	34	2,1	2,1	-	2,0	-	-
		8 m																																																																																																																																																												
		0°	0°	0°	20°	40°																																																																																																																																																								
19 m		0°	20°	40°	0°	0°																																																																																																																																																								
m	t	t	t	t	t	t																																																																																																																																																								
5	7,4	-	-	-	-	-																																																																																																																																																								
6	7,3	-	-	-	-	-																																																																																																																																																								
7	7,0	-	-	-	-	-																																																																																																																																																								
8	6,7	-	-	-	-	-																																																																																																																																																								
9	6,4	-	-	-	-	-																																																																																																																																																								
10	6,1	-	-	-	-	-																																																																																																																																																								
12	5,5	4,9	-	-	-	-																																																																																																																																																								
14	4,9	4,5	-	4,1	-	-																																																																																																																																																								
16	4,5	4,1	-	3,8	-	-																																																																																																																																																								
18	4,1	3,7	3,5	3,4	-	-																																																																																																																																																								
20	3,7	3,4	3,2	3,2	-	-																																																																																																																																																								
22	3,3	3,2	3,0	2,9	2,5	-																																																																																																																																																								
24	3,1	2,9	2,8	2,7	2,4	-																																																																																																																																																								
26	2,8	2,7	2,7	2,5	2,2	-																																																																																																																																																								
28	2,6	2,5	2,5	2,3	2,1	-																																																																																																																																																								
30	2,4	2,3	2,4	2,2	2,0	-																																																																																																																																																								
32	2,2	2,2	-	2,1	2,0	-																																																																																																																																																								
34	2,1	2,1	-	2,0	-	-																																																																																																																																																								

14,2 t			8,10 m x 7,20 m					360°					ISO	
 50,0 m			 45,2 m					 41,8 m						
														
m	t	t	m	t	t	t	t	m	t	t	t	t	t	
16	2,2	-	14	3,0	-	-	-	14	4,0	-	-	-	-	
18	2,2	-	16	3,0	-	-	-	16	3,9	-	-	-	-	
20	2,2	-	18	3,0	-	-	-	18	3,8	-	-	-	-	
22	2,2	-	20	3,0	-	-	-	20	3,7	3,4	-	-	-	
24	2,2	2,1	22	3,0	2,9	-	-	22	3,6	3,2	-	-	-	
26	2,2	2,1	24	3,0	2,8	-	-	24	3,4	3,1	-	2,8	-	
28	2,2	2,1	26	2,9	2,8	-	2,5	26	3,3	3,0	2,8	2,7	-	
30	2,2	2,1	28	2,8	2,7	2,5	2,4	28	3,1	2,8	2,7	2,6	-	
32	1,8	2,1	30	2,6	2,6	2,5	2,3	30	2,9	2,7	2,6	2,5	2,0	
34	1,4	2,1	32	2,4	2,5	2,4	2,2	32	2,5	2,6	2,5	2,4	2,0	
36	1,0	1,7	34	1,9	2,3	2,3	2,2	34	2,1	2,5	2,4	2,3	1,9	
38	0,7	1,3	36	1,6	2,2	2,3	2,1	36	1,7	2,3	2,3	2,2	1,9	
40	-	1,0	38	1,3	1,8	2,1	1,8	38	1,4	1,9	2,2	2,1	1,8	
42	-	0,7	40	1,0	1,5	1,7	1,4	40	1,1	1,6	2,0	1,8	1,8	
			42	0,7	1,2	1,4	1,1	42	0,9	1,3	1,7	1,5	1,7	
			44	-	0,9	1,1	0,8	44	-	1,0	1,3	1,1	1,4	
			46	-	-	0,8	-	46	-	0,7	1,0	0,9	1,0	
								48	-	-	0,7	-	0,7	

 37,5 m												
												
m	t	t	m	t	t	t	t					
12	4,8	-	12	4,8	-	-	-					
14	4,6	-	14	4,6	-	-	-					
16	4,4	-	16	4,4	-	-	-					
18	4,2	-	18	4,2	-	-	-					
20	4,0	3,6	20	4,0	3,6	-	-					
22	3,8	3,4	22	3,8	3,4	3,1	-					
24	3,6	3,2	24	3,6	3,2	3,0	2,9					
26	3,4	3,1	26	3,4	3,1	2,9	2,8					
28	3,2	3,0	28	3,2	3,0	2,7	2,7					
30	3,0	2,8	30	3,0	2,8	2,6	2,6					
32	2,9	2,7	32	2,9	2,7	2,6	2,4					
34	2,7	2,6	34	2,7	2,6	2,5	2,3					
36	2,3	2,4	36	2,3	2,4	2,2	2,1					
38	1,9	2,3	38	1,9	2,3	2,3	2,1					
40	1,6	2,0	40	1,6	2,0	2,2	2,0					
42	1,3	1,7	42	1,3	1,7	2,0	1,8					
44	1,0	1,4	44	1,0	1,4	1,6	1,5					
46	0,8	1,1	46	0,8	1,1	1,3	1,2					
48	-	0,8	48	-	0,8	1,0	0,9					
50	-	-	50	-	-	0,8	-					

 11,9 m							
							
m	t	t	m	t	t	t	
5	7,4	-	5	7,4	-	-	
6	7,3	-	6	7,3	-	-	
7	7,0	-	7	7,0	-	-	
8	6,7	-	8	6,7	-	-	
9	6,4	-	9	6,4	-	-	
10	6,1	-	10	6,1	-	-	
12	5,5	4,9	12	5,5	4,9	-	
14	4,9	4,5	14	4,9	4,5	4,1	
16	4,5	4,1	16	4,5	4,1	3,8	
18	4,1	3,7	18	4,1	3,7	3,5	
20	3,7	3,4	20	3,7	3,4	3,2	
22	3,3	3,2	22	3,3	3,2	3,0	
24	3,1	2,9	24	3,1	2,9	2,8	
26	2,8	2,7	26	2,8	2,7	2,7	
28	2,6	2,5	28	2,6	2,5	2,5	
30	2,4	2,3	30	2,4	2,3	2,4	
32	2,2	2,2	32	2,2	2,2	2,2	
34	2,1	2,1	34	2,1	2,1	2,0	

9,0 t  8,10 m x 7,20 m 360° ISO

50,0 m

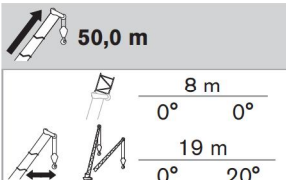

m	8 m	
	0°	0°
m	19 m	
	0°	20°
16	2,2	-
18	2,2	-
20	2,2	-
22	2,2	-
24	2,2	2,1
26	2,1	2,1
28	1,5	2,1
30	1,1	1,9
32	-	1,5
34	-	1,1
36	-	0,7

45,2 m

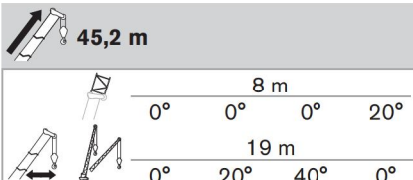

m	8 m			
	0°	0°	0°	20°
m	19 m			
	0°	20°	40°	0°
14	3,0	-	-	-
16	3,0	-	-	-
18	3,0	-	-	-
20	3,0	-	-	-
22	3,0	2,9	-	-
24	3,0	2,8	-	-
26	2,7	2,8	-	2,5
28	2,1	2,7	2,5	2,4
30	1,7	2,4	2,5	2,3
32	1,3	1,9	2,4	2,0
34	0,9	1,5	1,9	1,6
36	-	1,2	1,5	1,2
38	-	0,9	1,2	0,9
40	-	-	0,8	-

41,8 m

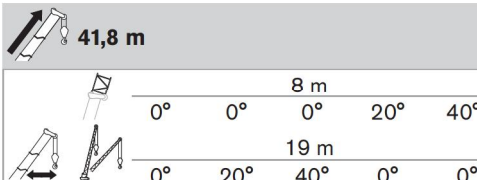

m	8 m				
	0°	0°	0°	20°	40°
m	19 m				
	0°	20°	40°	0°	0°
14	4,0	-	-	-	-
16	3,9	-	-	-	-
18	3,8	-	-	-	-
20	3,7	3,4	-	-	-
22	3,6	3,2	-	-	-
24	3,3	3,1	-	2,8	-
26	2,9	3,0	2,8	2,7	-
28	2,3	2,8	2,7	2,6	-
30	1,8	2,6	2,6	2,5	2,0
32	1,4	2,1	2,5	2,3	2,0
34	1,1	1,7	2,3	1,9	1,9
36	0,8	1,3	1,9	1,5	1,9
38	-	1,0	1,5	1,2	1,7
40	-	0,7	1,2	0,9	1,3
42	-	-	0,9	-	1,0

37,5 m

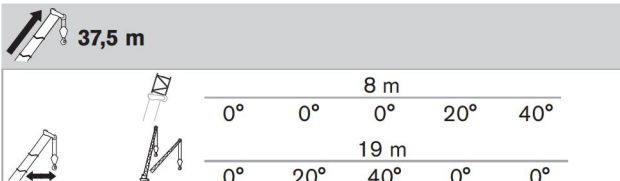



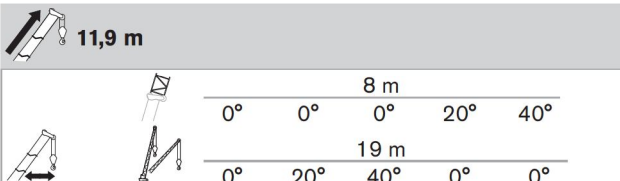

m	8 m				
	0°	0°	0°	20°	40°
m	19 m				
	0°	20°	40°	0°	0°
12	4,8	-	-	-	-
14	4,6	-	-	-	-
16	4,4	-	-	-	-
18	4,2	-	-	-	-
20	4,0	3,6	-	-	-
22	3,8	3,4	-	3,1	-
24	3,5	3,2	3,0	2,9	-
26	3,3	3,1	2,9	2,8	-
28	3,0	3,0	2,7	2,7	2,2
30	2,5	2,7	2,6	2,6	2,1
32	2,0	2,6	2,6	2,4	2,0
34	1,7	2,2	2,4	2,3	2,0
36	1,3	1,8	2,3	2,0	1,9
38	1,0	1,5	1,9	1,7	1,9
40	0,8	1,2	1,5	1,3	1,5
42	-	0,9	1,2	1,0	1,2
44	-	-	0,9	0,8	0,8



11,9 m

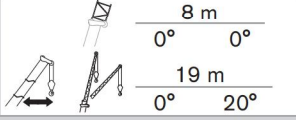
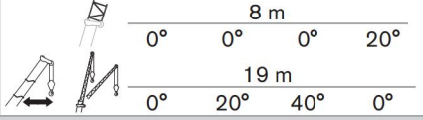
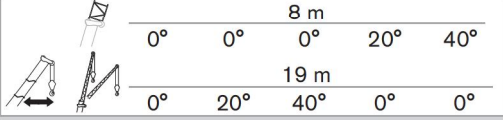

m	8 m			
	0°	0°	0°	20°
m	19 m			
	0°	20°	40°	0°
5	7,4	-	-	-
6	7,3	-	-	-
7	7,0	-	-	-
8	6,7	-	-	-
9	6,4	-	-	-
10	6,1	-	-	-
12	5,5	4,9	-	-
14	4,9	4,5	-	4,1
16	4,5	4,1	-	3,8
18	4,1	3,7	3,5	3,4
20	3,7	3,4	3,2	3,2
22	3,3	3,2	3,0	2,9
24	3,1	2,9	2,8	2,7
26	2,8	2,7	2,7	2,5
28	2,6	2,5	2,5	2,3
30	2,4	2,3	2,4	2,2
32	2,2	2,2	-	2,1
34	2,1	2,1	-	2,0

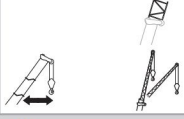
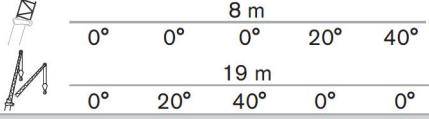
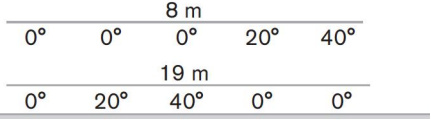
6,1 t			8,10 m x 7,20 m					360°					ISO
 50,0 m			 45,2 m					 41,8 m					
													
m	t	t	m	t	t	t	t	m	t	t	t	t	t
16	2,2	-	14	3,0	-	-	-	14	4,0	-	-	-	-
18	2,2	-	16	3,0	-	-	-	16	3,9	-	-	-	-
20	2,2	-	18	3,0	-	-	-	18	3,8	-	-	-	-
22	2,2	-	20	3,0	-	-	-	20	3,7	3,4	-	-	-
24	1,9	2,1	22	2,9	2,9	-	-	22	3,4	3,2	-	-	-
26	1,3	2,1	24	2,5	2,8	-	-	24	2,7	3,1	-	2,8	-
28	0,8	1,7	26	1,9	2,7	-	2,5	26	2,1	2,9	2,8	2,7	-
30	-	1,3	28	1,4	2,3	2,5	2,4	28	1,6	2,4	2,7	2,5	-
32	-	0,9	30	1,0	1,8	2,3	1,8	30	1,2	1,9	2,5	2,2	2,0
			32	-	1,3	1,8	1,4	32	0,8	1,5	2,2	1,8	2,0
			34	-	1,0	1,4	1,0	34	-	1,1	1,7	1,4	1,9
			36	-	-	1,0	-	36	-	0,8	1,3	1,0	1,6
								38	-	-	1,0	0,7	1,2
								40	-	-	-	-	0,8

 37,5 m			8 m					19 m				
												
m	t	t	0°	0°	0°	20°	40°	0°	20°	40°	0°	0°
12	4,8	-	-	-	-	-	-	-	-	-	-	-
14	4,6	-	-	-	-	-	-	-	-	-	-	-
16	4,4	-	-	-	-	-	-	-	-	-	-	-
18	4,2	-	-	-	-	-	-	-	-	-	-	-
20	4,0	3,6	-	-	-	-	-	-	-	-	-	-
22	3,7	3,4	-	-	3,1	-	-	-	-	-	-	-
24	3,4	3,2	3,0	2,9	-	-	-	-	-	-	-	-
26	2,8	3,0	2,9	2,8	-	-	-	-	-	-	-	-
28	2,3	2,8	2,7	2,7	2,2	-	-	-	-	-	-	-
30	1,8	2,5	2,6	2,5	2,1	-	-	-	-	-	-	-
32	1,4	2,0	2,5	2,3	2,0	-	-	-	-	-	-	-
34	1,1	1,6	2,2	1,8	2,0	-	-	-	-	-	-	-
36	0,8	1,3	1,8	1,5	1,8	-	-	-	-	-	-	-
38	-	1,0	1,4	1,2	1,5	-	-	-	-	-	-	-
40	-	0,7	1,1	0,9	1,1	-	-	-	-	-	-	-
42	-	-	0,8	-	0,8	-	-	-	-	-	-	-

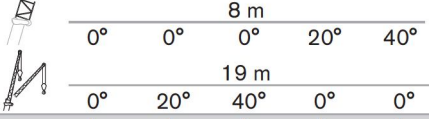
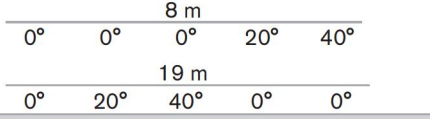
 11,9 m			8 m					19 m				
												
m	t	t	0°	0°	0°	20°	40°	0°	20°	40°	0°	0°
5	7,4	-	-	-	-	-	-	-	-	-	-	-
6	7,3	-	-	-	-	-	-	-	-	-	-	-
7	7,0	-	-	-	-	-	-	-	-	-	-	-
8	6,7	-	-	-	-	-	-	-	-	-	-	-
9	6,4	-	-	-	-	-	-	-	-	-	-	-
10	6,1	-	-	-	-	-	-	-	-	-	-	-
12	5,5	4,9	-	-	-	-	-	-	-	-	-	-
14	4,9	4,5	-	-	4,1	-	-	-	-	-	-	-
16	4,5	4,1	-	-	3,8	-	-	-	-	-	-	-
18	4,1	3,7	3,5	3,4	-	-	-	-	-	-	-	-
20	3,7	3,4	3,2	3,2	-	-	-	-	-	-	-	-
22	3,3	3,2	3,0	2,9	2,5	-	-	-	-	-	-	-
24	3,1	2,9	2,8	2,7	2,4	-	-	-	-	-	-	-
26	2,8	2,7	2,7	2,5	2,2	-	-	-	-	-	-	-
28	2,6	2,5	2,5	2,3	2,1	-	-	-	-	-	-	-
30	2,4	2,3	2,4	2,2	2,0	-	-	-	-	-	-	-
32	2,2	2,2	-	2,1	2,0	-	-	-	-	-	-	-
34	2,1	2,1	-	2,0	-	-	-	-	-	-	-	-

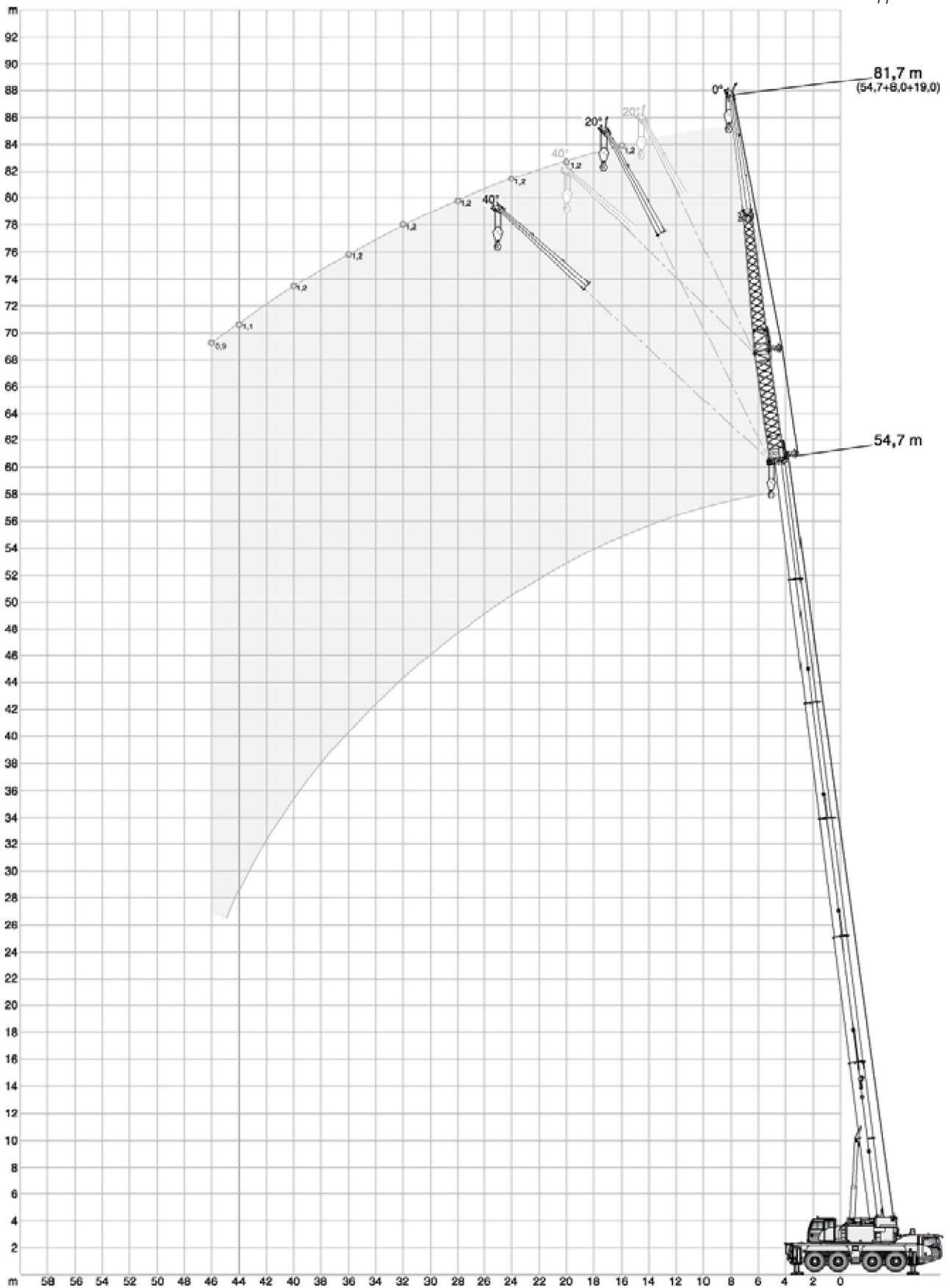
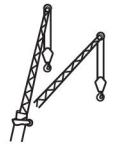

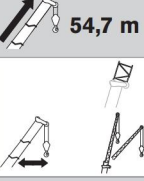
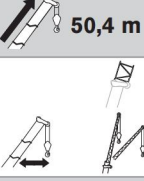
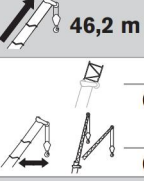
25,2 t			8,10 m x 7,20 m			360°			ISO																																																														
54,7 m			50,4 m			46,2 m																																																																	
																																																																							
<table border="1"> <thead> <tr> <th colspan="3">8 m</th> </tr> <tr> <th>0°</th> <th>0°</th> <th></th> </tr> </thead> <tbody> <tr> <td colspan="3">19 m</td> </tr> <tr> <th>0°</th> <th>20°</th> <th></th> </tr> </tbody> </table>			8 m			0°	0°		19 m			0°	20°		<table border="1"> <thead> <tr> <th colspan="3">8 m</th> </tr> <tr> <th>0°</th> <th>0°</th> <th></th> </tr> </thead> <tbody> <tr> <td colspan="3">19 m</td> </tr> <tr> <th>0°</th> <th>20°</th> <th></th> </tr> </tbody> </table>			8 m			0°	0°		19 m			0°	20°		<table border="1"> <thead> <tr> <th colspan="3">8 m</th> <th colspan="3">20°</th> <th colspan="3">40°</th> </tr> <tr> <th>0°</th> <th>0°</th> <th>0°</th> <th>20°</th> <th>20°</th> <th>40°</th> <th>0°</th> <th>0°</th> <th></th> </tr> </thead> <tbody> <tr> <td colspan="3">19 m</td> <td colspan="3"></td> <td colspan="3"></td> </tr> <tr> <th>0°</th> <th>20°</th> <th>40°</th> <th>0°</th> <th>0°</th> <th></th> <th></th> <th></th> <th></th> </tr> </tbody> </table>			8 m			20°			40°			0°	0°	0°	20°	20°	40°	0°	0°		19 m									0°	20°	40°	0°	0°							
8 m																																																																							
0°	0°																																																																						
19 m																																																																							
0°	20°																																																																						
8 m																																																																							
0°	0°																																																																						
19 m																																																																							
0°	20°																																																																						
8 m			20°			40°																																																																	
0°	0°	0°	20°	20°	40°	0°	0°																																																																
19 m																																																																							
0°	20°	40°	0°	0°																																																																			
m	t	t	m	t	t	m	t	t	t	t																																																													
16	1,2	-	16	2,0	-	14	2,9	-	-	-																																																													
18	1,2	-	18	2,0	-	16	2,8	-	-	-																																																													
20	1,2	-	20	2,0	-	18	2,8	-	-	-																																																													
22	1,2	-	22	2,0	-	20	2,7	-	-	-																																																													
24	1,2	-	24	2,0	1,9	22	2,6	2,7	-	-																																																													
26	1,2	-	26	2,0	1,9	24	2,6	2,6	-	-																																																													
28	1,2	-	28	2,0	1,9	26	2,5	2,6	-	2,5																																																													
30	1,2	-	30	1,9	1,9	28	2,5	2,5	2,5	2,4																																																													
32	1,2	-	32	1,9	1,9	30	2,4	2,4	2,5	2,3																																																													
34	1,2	-	34	1,9	1,9	32	2,3	2,4	2,4	2,2																																																													
36	1,2	-	36	1,9	1,9	34	2,3	2,3	2,3	2,2																																																													
38	1,2	-	38	1,8	1,8	36	2,2	2,3	2,3	2,1																																																													
40	1,2	-	40	1,7	1,8	38	2,1	2,2	2,2	2,0																																																													
42	1,2	-	42	1,5	1,8	40	2,0	2,1	2,1	2,0																																																													
44	1,1	-	44	1,3	1,7	42	1,7	2,0	2,1	1,9																																																													
46	0,9	-	46	1,2	1,4	44	1,6	1,8	2,0	1,8																																																													
			48	1,0	1,1	46	1,4	1,7	1,8	1,6																																																													
			50	0,8	0,9	48	1,3	1,4	1,5	1,3																																																													
						50	1,1	1,1	1,1	1,0																																																													
						52	0,9	0,9	0,9	0,7																																																													
						54	0,7	-	-	-																																																													

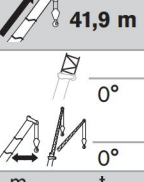
41,9 m																													
																													
<table border="1"> <thead> <tr> <th colspan="6">8 m</th> </tr> <tr> <th>0°</th> <th>0°</th> <th>0°</th> <th>20°</th> <th>40°</th> <th></th> </tr> </thead> <tbody> <tr> <td colspan="6">19 m</td> </tr> <tr> <th>0°</th> <th>20°</th> <th>40°</th> <th>0°</th> <th>0°</th> <th></th> </tr> </tbody> </table>						8 m						0°	0°	0°	20°	40°		19 m						0°	20°	40°	0°	0°	
8 m																													
0°	0°	0°	20°	40°																									
19 m																													
0°	20°	40°	0°	0°																									
m	t	t	t	t	t																								
14	3,4	-	-	-	-																								
16	3,3	-	-	-	-																								
18	3,2	-	-	-	-																								
20	3,1	3,2	-	-	-																								
22	3,1	3,1	-	-	-																								
24	3,0	3,0	-	2,8	-																								
26	2,9	2,9	2,7	2,6	-																								
28	2,8	2,8	2,6	2,5	-																								
30	2,7	2,7	2,6	2,4	2,0																								
32	2,6	2,6	2,5	2,4	2,0																								
34	2,6	2,5	2,4	2,3	1,9																								
36	2,5	2,4	2,3	2,2	1,9																								
38	2,4	2,3	2,2	2,1	1,8																								
40	2,2	2,2	2,2	2,0	1,8																								
42	1,9	2,2	2,1	2,0	1,7																								
44	1,6	2,0	2,1	1,9	1,7																								
46	1,5	1,7	1,9	1,8	1,7																								
48	1,4	1,5	1,7	1,5	1,7																								
50	1,2	1,3	1,4	1,2	1,4																								
52	1,0	1,2	1,1	1,0	1,1																								
54	0,9	1,0	0,8	0,7	0,8																								
56	0,8	0,8	-	-	-																								

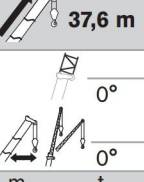
37,6 m																													
																													
<table border="1"> <thead> <tr> <th colspan="6">8 m</th> </tr> <tr> <th>0°</th> <th>0°</th> <th>0°</th> <th>20°</th> <th>40°</th> <th></th> </tr> </thead> <tbody> <tr> <td colspan="6">19 m</td> </tr> <tr> <th>0°</th> <th>20°</th> <th>40°</th> <th>0°</th> <th>0°</th> <th></th> </tr> </tbody> </table>						8 m						0°	0°	0°	20°	40°		19 m						0°	20°	40°	0°	0°	
8 m																													
0°	0°	0°	20°	40°																									
19 m																													
0°	20°	40°	0°	0°																									
m	t	t	t	t	t																								
12	4,0	-	-	-	-																								
14	3,9	-	-	-	-																								
16	3,7	-	-	-	-																								
18	3,6	-	-	-	-																								
20	3,5	3,5	-	-	-																								
22	3,4	3,3	-	3,0	-																								
24	3,3	3,2	2,9	2,9	-																								
26	3,2	3,0	2,8	2,7	-																								
28	3,1	2,9	2,7	2,6	2,1																								
30	3,0	2,8	2,6	2,5	2,1																								
32	2,9	2,7	2,5	2,4	2,0																								
34	2,7	2,5	2,4	2,3	1,9																								
36	2,6	2,5	2,4	2,2	1,9																								
38	2,5	2,4	2,3	2,1	1,9																								
40	2,4	2,3	2,2	2,1	1,8																								
42	2,1	2,2	2,2	2,0	1,8																								
44	1,9	2,1	2,1	1,9	1,8																								
46	1,7	1,9	2,0	1,9	1,7																								
48	1,5	1,7	1,8	1,7	1,7																								
50	1,3	1,5	1,6	1,5	1,6																								
52	1,2	1,3	1,4	1,3	1,3																								
54	1,0	1,2	-	1,1	1,0																								
56	1,0	1,0	-	0,9	-																								
58	0,9	0,8	-	-	-																								

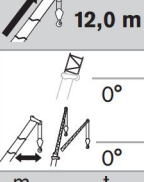
12,0 m																													
																													
<table border="1"> <thead> <tr> <th colspan="6">8 m</th> </tr> <tr> <th>0°</th> <th>0°</th> <th>0°</th> <th>20°</th> <th>40°</th> <th></th> </tr> </thead> <tbody> <tr> <td colspan="6">19 m</td> </tr> <tr> <th>0°</th> <th>20°</th> <th>40°</th> <th>0°</th> <th>0°</th> <th></th> </tr> </tbody> </table>						8 m						0°	0°	0°	20°	40°		19 m						0°	20°	40°	0°	0°	
8 m																													
0°	0°	0°	20°	40°																									
19 m																													
0°	20°	40°	0°	0°																									
m	t	t	t	t	t																								
5	7,2	-	-	-	-																								
6	7,1	-	-	-	-																								
7	6,8	-	-	-	-																								
8	6,5	-	-	-	-																								
9	6,3	-	-	-	-																								
10	6,0	-	-	-	-																								
12	5,4	4,9	-	-	-																								
14	4,8	4,4	-	4,1	-																								
16	4,4	4,0	-	3,7	-																								
18	4,0	3,7	3,5	3,4	-																								
20	3,6	3,4	3,2	3,2	-																								
22	3,3	3,1	3,0	2,9	2,5																								
24	3,1	2,9	2,8	2,7	2,4																								
26	2,8	2,7	2,6	2,5	2,2																								
28	2,6	2,5	2,5	2,3	2,1																								
30	2,4	2,3	2,4	2,2	2,0																								
32	2,2	2,2	-	2,1	2,0																								
34	2,1	2,1	-	2,0	-																								

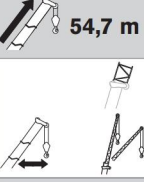
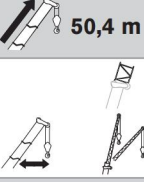
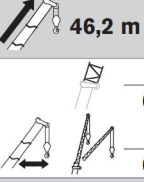
20,2 t			8,10 m x 7,20 m			360°					ISO																																												
54,7 m			50,4 m			46,2 m																																																	
																																																							
<table border="1"> <thead> <tr> <th colspan="3">8 m</th> </tr> <tr> <th>0°</th> <th>0°</th> <th></th> </tr> </thead> <tbody> <tr> <td colspan="3">19 m</td> </tr> <tr> <th>0°</th> <th>20°</th> <th></th> </tr> </tbody> </table>			8 m			0°	0°		19 m			0°	20°		<table border="1"> <thead> <tr> <th colspan="3">8 m</th> </tr> <tr> <th>0°</th> <th>0°</th> <th></th> </tr> </thead> <tbody> <tr> <td colspan="3">19 m</td> </tr> <tr> <th>0°</th> <th>20°</th> <th></th> </tr> </tbody> </table>			8 m			0°	0°		19 m			0°	20°		<table border="1"> <thead> <tr> <th colspan="5">8 m</th> </tr> <tr> <th>0°</th> <th>0°</th> <th>0°</th> <th>20°</th> <th>40°</th> </tr> </thead> <tbody> <tr> <td colspan="5">19 m</td> </tr> <tr> <th>0°</th> <th>20°</th> <th>40°</th> <th>0°</th> <th>0°</th> </tr> </tbody> </table>					8 m					0°	0°	0°	20°	40°	19 m					0°	20°	40°	0°	0°	
8 m																																																							
0°	0°																																																						
19 m																																																							
0°	20°																																																						
8 m																																																							
0°	0°																																																						
19 m																																																							
0°	20°																																																						
8 m																																																							
0°	0°	0°	20°	40°																																																			
19 m																																																							
0°	20°	40°	0°	0°																																																			
m	t	t	m	t	t	m	t	t	t	t																																													
16	1,2	-	16	2,0	-	14	2,9	-	-	-																																													
18	1,2	-	18	2,0	-	16	2,8	-	-	-																																													
20	1,2	-	20	2,0	-	18	2,8	-	-	-																																													
22	1,2	-	22	2,0	-	20	2,7	-	-	-																																													
24	1,2	-	24	2,0	1,9	22	2,6	2,7	-	-																																													
26	1,2	-	26	2,0	1,9	24	2,6	2,6	-	-																																													
28	1,2	-	28	2,0	1,9	26	2,5	2,6	-	2,5																																													
30	1,2	-	30	1,9	1,9	28	2,5	2,5	2,5	2,4																																													
32	1,2	-	32	1,9	1,9	30	2,4	2,4	2,5	2,3																																													
34	1,2	-	34	1,9	1,9	32	2,3	2,4	2,4	2,2																																													
36	1,2	-	36	1,8	1,9	34	2,3	2,3	2,3	2,2																																													
38	1,2	-	38	1,5	1,8	36	2,0	2,3	2,3	2,1																																													
40	1,0	-	40	1,4	1,7	38	1,8	2,2	2,2	2,0																																													
42	0,7	-	42	1,1	1,3	40	1,6	2,0	2,1	2,0																																													
			44	0,9	1,0	42	1,5	1,7	1,9	1,7																																													
			46	-	0,8	44	1,4	1,4	1,6	1,3																																													
						46	1,1	1,1	1,2	1,0																																													
						48	0,9	0,8	0,9	0,7																																													

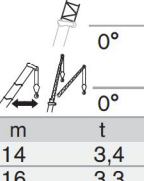
41,9 m																			
																			
<table border="1"> <thead> <tr> <th colspan="3">8 m</th> </tr> <tr> <th>0°</th> <th>0°</th> <th>0°</th> </tr> </thead> <tbody> <tr> <td colspan="3">19 m</td> </tr> <tr> <th>0°</th> <th>20°</th> <th>0°</th> </tr> </tbody> </table>			8 m			0°	0°	0°	19 m			0°	20°	0°					
8 m																			
0°	0°	0°																	
19 m																			
0°	20°	0°																	
m	t	t	t	t	t														
14	3,4	-	-	-	-														
16	3,3	-	-	-	-														
18	3,2	-	-	-	-														
20	3,1	3,2	-	-	-														
22	3,1	3,1	-	-	-														
24	3,0	3,0	-	2,8	-														
26	2,9	2,9	2,7	2,6	-														
28	2,8	2,8	2,6	2,5	-														
30	2,7	2,7	2,6	2,4	2,0														
32	2,6	2,6	2,5	2,4	2,0														
34	2,6	2,5	2,4	2,3	1,9														
36	2,4	2,4	2,3	2,2	1,9														
38	2,0	2,3	2,2	2,1	1,8														
40	1,9	2,1	2,2	2,0	1,8														
42	1,7	1,9	2,1	1,9	1,7														
44	1,4	1,7	1,8	1,6	1,7														
46	1,3	1,5	1,4	1,3	1,6														
48	1,1	1,2	1,1	1,0	1,2														
50	0,9	0,9	0,8	-	0,9														
52	0,7	-	-	-	-														

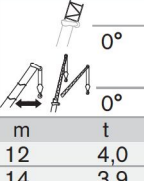
37,6 m																			
																			
<table border="1"> <thead> <tr> <th colspan="3">8 m</th> </tr> <tr> <th>0°</th> <th>0°</th> <th>0°</th> </tr> </thead> <tbody> <tr> <td colspan="3">19 m</td> </tr> <tr> <th>0°</th> <th>20°</th> <th>0°</th> </tr> </tbody> </table>			8 m			0°	0°	0°	19 m			0°	20°	0°					
8 m																			
0°	0°	0°																	
19 m																			
0°	20°	0°																	
m	t	t	t	t	t														
12	4,0	-	-	-	-														
14	3,9	-	-	-	-														
16	3,7	-	-	-	-														
18	3,6	-	-	-	-														
20	3,5	3,5	-	-	-														
22	3,4	3,3	-	3,0	-														
24	3,3	3,2	2,9	2,9	-														
26	3,2	3,0	2,8	2,7	-														
28	3,1	2,9	2,7	2,6	2,1														
30	3,0	2,8	2,6	2,5	2,1														
32	2,9	2,7	2,5	2,4	2,0														
34	2,7	2,5	2,4	2,3	1,9														
36	2,5	2,5	2,4	2,2	1,9														
38	2,4	2,4	2,3	2,1	1,9														
40	2,1	2,3	2,2	2,1	1,8														
42	1,9	2,1	2,2	2,0	1,8														
44	1,6	1,8	2,0	1,9	1,8														
46	1,4	1,6	1,8	1,6	1,7														
48	1,3	1,4	1,4	1,3	1,4														
50	1,1	1,2	1,1	1,1	1,1														
52	0,9	0,9	0,9	0,8	0,8														
54	0,8	0,7	-	-	-														

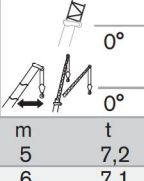
12,0 m																			
																			
<table border="1"> <thead> <tr> <th colspan="3">8 m</th> </tr> <tr> <th>0°</th> <th>0°</th> <th>0°</th> </tr> </thead> <tbody> <tr> <td colspan="3">19 m</td> </tr> <tr> <th>0°</th> <th>20°</th> <th>0°</th> </tr> </tbody> </table>			8 m			0°	0°	0°	19 m			0°	20°	0°					
8 m																			
0°	0°	0°																	
19 m																			
0°	20°	0°																	
m	t	t	t	t	t														
5	7,2	-	-	-	-														
6	7,1	-	-	-	-														
7	6,8	-	-	-	-														
8	6,5	-	-	-	-														
9	6,3	-	-	-	-														
10	6,0	-	-	-	-														
12	5,4	4,9	-	-	-														
14	4,8	4,4	-	4,1	-														
16	4,4	4,0	-	3,7	-														
18	4,0	3,7	3,5	3,4	-														
20	3,6	3,4	3,2	3,2	-														
22	3,3	3,1	3,0	2,9	2,5														
24	3,1	2,9	2,8	2,7	2,4														
26	2,8	2,7	2,6	2,5	2,2														
28	2,6	2,5	2,5	2,3	2,1														
30	2,4	2,3	2,4	2,2	2,0														
32	2,2	2,2	-	2,1	2,0														
34	2,1	2,1	-	2,0	-														

14,2 t 8,10 m x 7,20 m 360° ISO

54,7 m

m	t	t
16	1,2	-
18	1,2	-
20	1,2	-
22	1,2	-
24	1,2	-
26	1,2	-
28	1,2	-
30	1,2	-
32	1,2	-
34	1,0	-

50,4 m

m	t	t
16	2,0	-
18	2,0	-
20	2,0	-
22	2,0	-
24	2,0	1,9
26	2,0	1,9
28	2,0	1,9
30	1,9	1,9
32	1,6	1,9
34	1,4	1,9
36	1,1	1,4
38	0,8	1,1
40	-	0,7

46,2 m

m	t	t	t	t	t
14	2,9	-	-	-	-
16	2,8	-	-	-	-
18	2,8	-	-	-	-
20	2,7	-	-	-	-
22	2,6	2,7	-	-	-
24	2,6	2,6	-	-	-
26	2,5	2,6	-	2,5	-
28	2,5	2,5	2,5	2,4	-
30	2,2	2,4	2,5	2,3	-
32	2,0	2,4	2,4	2,2	-
34	1,8	2,2	2,3	2,2	-
36	1,7	1,8	2,2	1,9	-
38	1,3	1,5	1,8	1,5	-
40	1,1	1,1	1,4	1,1	-
42	0,8	0,8	1,1	0,8	-
44	-	-	0,7	-	-

41,9 m

m	t	t	t	t	t
14	3,4	-	-	-	-
16	3,3	-	-	-	-
18	3,2	-	-	-	-
20	3,1	3,2	-	-	-
22	3,1	3,1	-	-	-
24	3,0	3,0	-	2,8	-
26	2,9	2,9	2,7	2,6	-
28	2,8	2,8	2,6	2,5	-
30	2,6	2,7	2,6	2,4	2,0
32	2,4	2,6	2,5	2,4	2,0
34	2,2	2,4	2,4	2,3	1,9
36	1,8	2,3	2,3	2,1	1,9
38	1,7	2,0	2,2	1,8	1,8
40	1,5	1,6	1,8	1,5	1,8
42	1,2	1,3	1,4	1,1	1,6
44	0,9	1,0	1,0	0,8	1,2
46	-	0,8	0,7	-	0,8

37,6 m

m	t	t	t	t	t
12	4,0	-	-	-	-
14	3,9	-	-	-	-
16	3,7	-	-	-	-
18	3,6	-	-	-	-
20	3,5	3,5	-	-	-
22	3,4	3,3	-	3,0	-
24	3,3	3,2	2,9	2,9	-
26	3,2	3,0	2,8	2,7	-
28	3,1	2,9	2,7	2,6	2,1
30	2,9	2,8	2,6	2,5	2,1
32	2,7	2,7	2,5	2,4	2,0
34	2,4	2,5	2,4	2,3	1,9
36	2,2	2,4	2,4	2,2	1,9
38	1,8	2,2	2,3	2,1	1,9
40	1,6	1,9	2,1	1,9	1,8
42	1,5	1,6	1,7	1,5	1,8
44	1,2	1,3	1,4	1,2	1,4
46	1,0	1,0	1,0	0,9	1,0
48	0,8	0,7	0,7	-	0,7

12,0 m

m	t	t	t	t	t
5	7,2	-	-	-	-
6	7,1	-	-	-	-
7	6,8	-	-	-	-
8	6,5	-	-	-	-
9	6,3	-	-	-	-
10	6,0	-	-	-	-
12	5,4	4,9	-	-	-
14	4,8	4,4	-	4,1	-
16	4,4	4,0	-	3,7	-
18	4,0	3,7	3,5	3,4	-
20	3,6	3,4	3,2	3,2	-
22	3,3	3,1	3,0	2,9	2,5
24	3,1	2,9	2,8	2,7	2,4
26	2,8	2,7	2,6	2,5	2,2
28	2,6	2,5	2,5	2,3	2,1
30	2,4	2,3	2,4	2,2	2,0
32	2,2	2,2	-	2,1	2,0
34	2,1	2,1	-	2,0	-

9,0 t			8,10 m x 7,20 m			360°			ISO		
54,7 m			50,4 m			46,2 m					
8 m			8 m			8 m			8 m		
0° 0°			0° 0°			0° 0° 0° 20° 40°					
19 m			19 m			19 m					
0° 20°			0° 20°			0° 20° 40° 0° 0°					
m	t	t	m	t	t	m	t	t	t	t	t
16	1,2	-	16	2,0	-	14	2,9	-	-	-	-
18	1,2	-	18	2,0	-	16	2,8	-	-	-	-
20	1,2	-	20	2,0	-	18	2,8	-	-	-	-
22	1,2	-	22	2,0	-	20	2,7	-	-	-	-
24	1,2	-	24	2,0	1,9	22	2,6	2,7	-	-	-
26	1,2	-	26	1,8	1,9	24	2,6	2,6	-	-	-
28	1,1	-	28	1,6	1,9	26	2,3	2,6	-	2,5	-
			30	1,1	1,7	28	2,0	2,4	2,5	2,4	-
			32	0,7	1,2	30	1,8	2,1	2,5	2,2	-
			34	-	0,8	32	1,4	1,6	2,2	1,7	-
						34	1,0	1,2	1,7	1,3	-
						36	0,7	0,9	1,3	0,9	-
						38	-	-	0,9	-	-

41,9 m											
8 m			8 m			8 m			8 m		
0° 0° 0° 20° 40°			0° 0° 0° 20° 40°			0° 0° 0° 20° 40°			0° 0° 0° 20° 40°		
19 m			19 m			19 m			19 m		
0° 20° 40° 0° 0°			0° 20° 40° 0° 0°			0° 20° 40° 0° 0°			0° 20° 40° 0° 0°		
m	t	t	t	t	t	m	t	t	t	t	t
14	3,4	-	-	-	-	12	4,0	-	-	-	-
16	3,3	-	-	-	-	14	3,9	-	-	-	-
18	3,2	-	-	-	-	16	3,7	-	-	-	-
20	3,1	3,2	-	-	-	18	3,6	-	-	-	-
22	3,1	3,1	-	-	-	20	3,5	3,5	-	-	-
24	3,0	3,0	-	2,8	-	22	3,4	3,3	-	3,0	-
26	2,6	2,9	2,7	2,6	-	24	3,3	3,2	2,9	2,9	-
28	2,4	2,7	2,6	2,5	-	26	3,0	3,0	2,8	2,7	-
30	2,1	2,5	2,6	2,4	2,0	28	2,8	2,9	2,7	2,6	2,1
32	1,8	2,2	2,4	2,1	2,0	30	2,4	2,7	2,6	2,5	2,1
34	1,5	1,8	2,1	1,7	1,9	32	2,2	2,5	2,5	2,4	2,0
36	1,1	1,4	1,6	1,3	1,9	34	1,9	2,2	2,4	2,2	1,9
38	0,8	1,1	1,2	0,9	1,5	36	1,6	1,8	2,1	1,8	1,9
40	-	0,8	0,9	-	1,1	38	1,3	1,4	1,7	1,4	1,8
42	-	-	-	-	0,8	40	1,0	1,1	1,3	1,1	1,4
						42	0,7	0,8	1,0	0,8	1,0

37,6 m											
8 m			8 m			8 m			8 m		
0° 0° 0° 20° 40°			0° 0° 0° 20° 40°			0° 0° 0° 20° 40°			0° 0° 0° 20° 40°		
19 m			19 m			19 m			19 m		
0° 20° 40° 0° 0°			0° 20° 40° 0° 0°			0° 20° 40° 0° 0°			0° 20° 40° 0° 0°		
m	t	t	t	t	t	m	t	t	t	t	t
12	4,0	-	-	-	-	5	7,2	-	-	-	-
14	3,9	-	-	-	-	6	7,1	-	-	-	-
16	3,7	-	-	-	-	7	6,8	-	-	-	-
18	3,6	-	-	-	-	8	6,5	-	-	-	-
20	3,5	3,5	-	-	-	9	6,3	-	-	-	-
22	3,4	3,3	-	3,0	-	10	6,0	-	-	-	-
24	3,3	3,2	2,9	2,9	-	12	5,4	4,9	-	-	-
26	3,0	3,0	2,8	2,7	-	14	4,8	4,4	-	4,1	-
28	2,8	2,9	2,7	2,6	2,1	16	4,4	4,0	-	3,7	-
30	2,4	2,7	2,6	2,5	2,1	18	4,0	3,7	3,5	3,4	-
32	2,2	2,5	2,5	2,4	2,0	20	3,6	3,4	3,2	3,2	-
34	1,9	2,2	2,4	2,2	1,9	22	3,3	3,1	3,0	2,9	2,5
36	1,6	1,8	2,1	1,8	1,9	24	3,1	2,9	2,8	2,7	2,4
38	1,3	1,4	1,7	1,4	1,8	26	2,8	2,7	2,6	2,5	2,2
40	1,0	1,1	1,3	1,1	1,4	28	2,6	2,5	2,5	2,3	2,1
42	0,7	0,8	1,0	0,8	1,0	30	2,4	2,3	2,4	2,2	2,0
						32	2,2	2,2	-	2,1	2,0
						34	2,1	2,1	-	2,0	-

12,0 m											
8 m			8 m			8 m			8 m		
0° 0° 0° 20° 40°			0° 0° 0° 20° 40°			0° 0° 0° 20° 40°			0° 0° 0° 20° 40°		
19 m			19 m			19 m			19 m		
0° 20° 40° 0° 0°			0° 20° 40° 0° 0°			0° 20° 40° 0° 0°			0° 20° 40° 0° 0°		
m	t	t	t	t	t	m	t	t	t	t	t
5	7,2	-	-	-	-	5	7,2	-	-	-	-
6	7,1	-	-	-	-	6	7,1	-	-	-	-
7	6,8	-	-	-	-	7	6,8	-	-	-	-
8	6,5	-	-	-	-	8	6,5	-	-	-	-
9	6,3	-	-	-	-	9	6,3	-	-	-	-
10	6,0	-	-	-	-	10	6,0	-	-	-	-
12	5,4	4,9	-	-	-	12	5,4	4,9	-	-	-
14	4,8	4,4	-	4,1	-	14	4,8	4,4	-	4,1	-
16	4,4	4,0	-	3,7	-	16	4,4	4,0	-	3,7	-
18	4,0	3,7	3,5	3,4	-	18	4,0	3,7	3,5	3,4	-
20	3,6	3,4	3,2	3,2	-	20	3,6	3,4	3,2	3,2	-
22	3,3	3,1	3,0	2,9	2,5	22	3,3	3,1	3,0	2,9	2,5
24	3,1	2,9	2,8	2,7	2,4	24	3,1	2,9	2,8	2,7	2,4
26	2,8	2,7	2,6	2,5	2,2	26	2,8	2,7	2,6	2,5	2,2
28	2,6	2,5	2,5	2,3	2,1	28	2,6	2,5	2,5	2,3	2,1
30	2,4	2,3	2,4	2,2	2,0	30	2,4	2,3	2,4	2,2	2,0
32	2,2	2,2	-	2,1	2,0	32	2,2	2,2	-	2,1	2,0
34	2,1	2,1	-	2,0	-	34	2,1	2,1	-	2,0	-

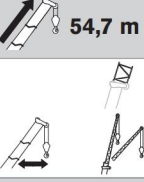
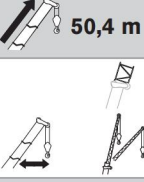
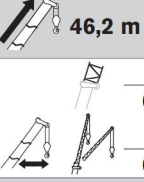

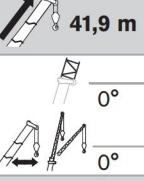
6,1 t			8,10 m x 7,20 m			360°			ISO																																																					
54,7 m			50,4 m			46,2 m																																																								
																																																														
<table border="1"> <thead> <tr> <th colspan="3">8 m</th> </tr> <tr> <th>0°</th> <th colspan="2">0°</th> </tr> </thead> <tbody> <tr> <td colspan="3">19 m</td> </tr> <tr> <th>0°</th> <th colspan="2">20°</th> </tr> </tbody> </table>			8 m			0°	0°		19 m			0°	20°		<table border="1"> <thead> <tr> <th colspan="3">8 m</th> </tr> <tr> <th>0°</th> <th colspan="2">0°</th> </tr> </thead> <tbody> <tr> <td colspan="3">19 m</td> </tr> <tr> <th>0°</th> <th colspan="2">20°</th> </tr> </tbody> </table>			8 m			0°	0°		19 m			0°	20°		<table border="1"> <thead> <tr> <th colspan="3">8 m</th> <th colspan="3">20° 40°</th> </tr> <tr> <th>0°</th> <th>0°</th> <th>0°</th> <th>20°</th> <th colspan="2">40°</th> </tr> </thead> <tbody> <tr> <td colspan="3">19 m</td> <td colspan="3"></td> </tr> <tr> <th>0°</th> <th>20°</th> <th>40°</th> <th>0°</th> <th colspan="2">0°</th> </tr> </tbody> </table>			8 m			20° 40°			0°	0°	0°	20°	40°		19 m						0°	20°	40°	0°	0°							
8 m																																																														
0°	0°																																																													
19 m																																																														
0°	20°																																																													
8 m																																																														
0°	0°																																																													
19 m																																																														
0°	20°																																																													
8 m			20° 40°																																																											
0°	0°	0°	20°	40°																																																										
19 m																																																														
0°	20°	40°	0°	0°																																																										
m	t	t	m	t	t	m	t	t	t	t	t																																																			
16	1,2	-	16	2,0	-	14	2,9	-	-	-	-																																																			
18	1,2	-	18	2,0	-	16	2,8	-	-	-	-																																																			
20	1,2	-	20	2,0	-	18	2,8	-	-	-	-																																																			
22	1,2	-	22	2,0	-	20	2,7	-	-	-	-																																																			
24	1,2	-	24	1,6	-	22	2,5	2,7	-	-	-																																																			
26	0,9	-	26	1,4	-	24	2,1	2,6	-	-	-																																																			
			28	0,9	-	26	2,0	2,4	-	2,5	-																																																			
						28	1,6	2,0	2,5	2,1	-																																																			
						30	1,1	1,5	2,1	1,6	-																																																			
						32	0,8	1,0	1,6	1,1	-																																																			
						34	-	-	1,1	0,7	-																																																			
						36	-	-	0,7	-	-																																																			

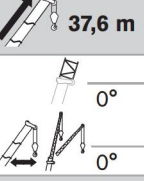

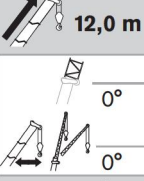
41,9 m																													
																													
<table border="1"> <thead> <tr> <th colspan="3">8 m</th> <th colspan="3">20° 40°</th> </tr> <tr> <th>0°</th> <th>0°</th> <th>0°</th> <th>20°</th> <th colspan="2">40°</th> </tr> </thead> <tbody> <tr> <td colspan="3">19 m</td> <td colspan="3"></td> </tr> <tr> <th>0°</th> <th>20°</th> <th>40°</th> <th>0°</th> <th colspan="2">0°</th> </tr> </tbody> </table>						8 m			20° 40°			0°	0°	0°	20°	40°		19 m						0°	20°	40°	0°	0°	
8 m			20° 40°																										
0°	0°	0°	20°	40°																									
19 m																													
0°	20°	40°	0°	0°																									
m	t	t	t	t	t																								
14	3,4	-	-	-	-																								
16	3,3	-	-	-	-																								
18	3,2	-	-	-	-																								
20	3,1	3,2	-	-	-																								
22	2,9	3,1	-	-	-																								
24	2,7	3,0	-	2,8	-																								
26	2,2	2,8	2,7	2,6	-																								
28	2,1	2,6	2,6	2,5	-																								
30	1,6	2,0	2,5	2,0	2,0																								
32	1,2	1,6	2,0	1,5	2,0																								
34	0,9	1,2	1,5	1,1	1,9																								
36	-	0,9	1,1	0,7	1,4																								
38	-	-	0,7	-	1,0																								

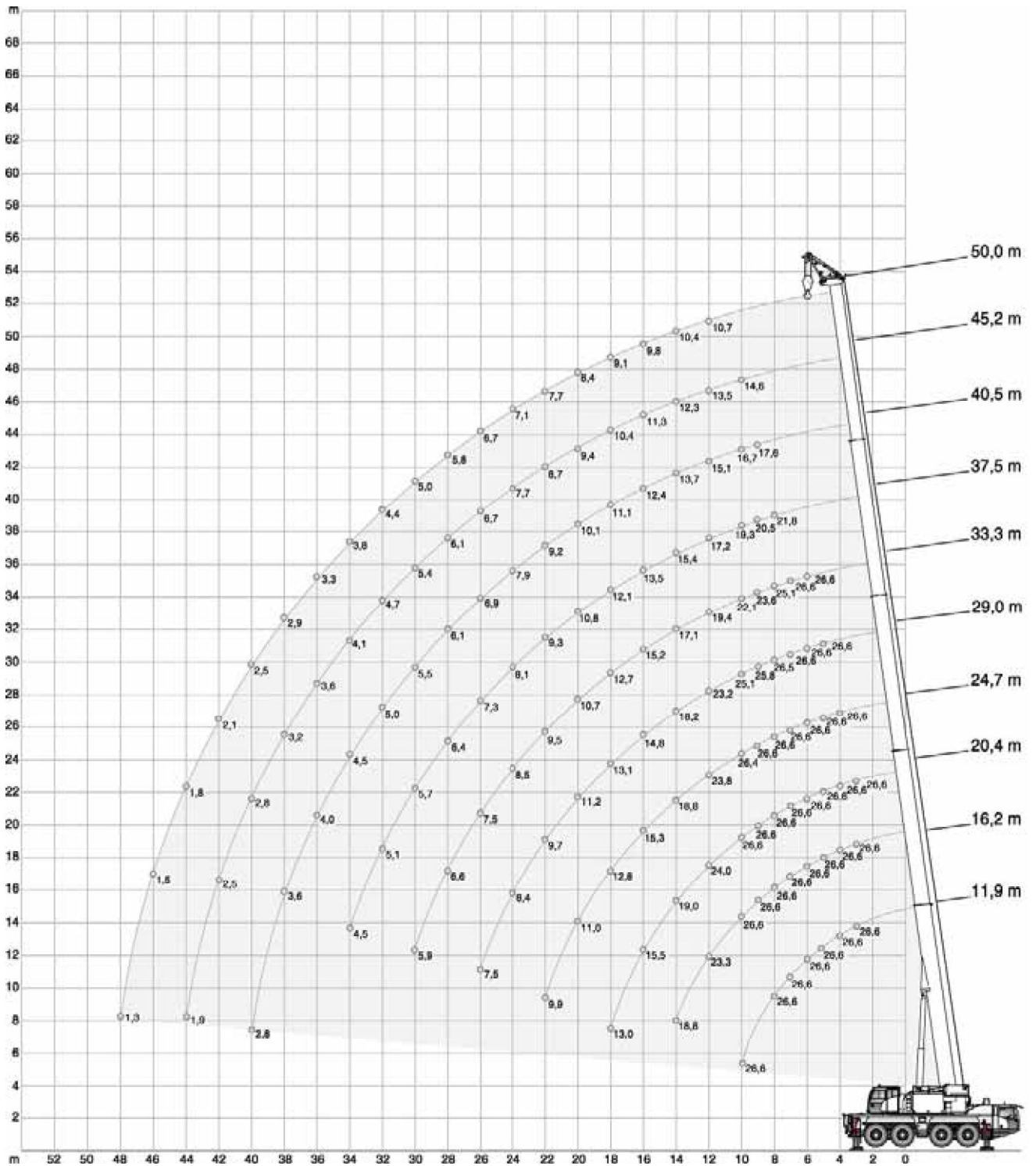
37,6 m																													
																													
<table border="1"> <thead> <tr> <th colspan="3">8 m</th> <th colspan="3">20° 40°</th> </tr> <tr> <th>0°</th> <th>0°</th> <th>0°</th> <th>20°</th> <th colspan="2">40°</th> </tr> </thead> <tbody> <tr> <td colspan="3">19 m</td> <td colspan="3"></td> </tr> <tr> <th>0°</th> <th>20°</th> <th>40°</th> <th>0°</th> <th colspan="2">0°</th> </tr> </tbody> </table>						8 m			20° 40°			0°	0°	0°	20°	40°		19 m						0°	20°	40°	0°	0°	
8 m			20° 40°																										
0°	0°	0°	20°	40°																									
19 m																													
0°	20°	40°	0°	0°																									
m	t	t	t	t	t																								
12	4,0	-	-	-	-																								
14	3,9	-	-	-	-																								
16	3,7	-	-	-	-																								
18	3,6	-	-	-	-																								
20	3,5	3,5	-	-	-																								
22	3,4	3,3	-	3,0	-																								
24	3,1	3,2	2,9	2,9	-																								
26	2,8	3,0	2,8	2,7	-																								
28	2,4	2,8	2,7	2,6	2,1																								
30	2,1	2,5	2,6	2,5	2,1																								
32	1,7	2,0	2,4	2,0	2,0																								
34	1,4	1,6	2,0	1,6	1,9																								
36	1,1	1,3	1,6	1,3	1,8																								
38	0,8	1,0	1,2	0,9	1,4																								
40	-	-	0,9	-	1,0																								

12,0 m																													
																													
<table border="1"> <thead> <tr> <th colspan="3">8 m</th> <th colspan="3">20° 40°</th> </tr> <tr> <th>0°</th> <th>0°</th> <th>0°</th> <th>20°</th> <th colspan="2">40°</th> </tr> </thead> <tbody> <tr> <td colspan="3">19 m</td> <td colspan="3"></td> </tr> <tr> <th>0°</th> <th>20°</th> <th>40°</th> <th>0°</th> <th colspan="2">0°</th> </tr> </tbody> </table>						8 m			20° 40°			0°	0°	0°	20°	40°		19 m						0°	20°	40°	0°	0°	
8 m			20° 40°																										
0°	0°	0°	20°	40°																									
19 m																													
0°	20°	40°	0°	0°																									
m	t	t	t	t	t																								
5	7,2	-	-	-	-																								
6	7,1	-	-	-	-																								
7	6,8	-	-	-	-																								
8	6,5	-	-	-	-																								
9	6,3	-	-	-	-																								
10	6,0	-	-	-	-																								
12	5,4	4,9	-	-	-																								
14	4,8	4,4	-	4,1	-																								
16	4,4	4,0	-	3,7	-																								
18	4,0	3,7	3,5	3,4	-																								
20	3,6	3,4	3,2	3,2	-																								
22	3,3	3,1	3,0	2,9	2,5																								
24	3,1	2,9	2,8	2,7	2,4																								
26	2,8	2,7	2,6	2,5	2,2																								
28	2,6	2,5	2,5	2,3	2,1																								
30	2,4	2,3	2,4	2,2	2,0																								
32	2,2	2,2	-	2,1	2,0																								
34	2,1	2,1	-	2,0	-																								







25,2 t		8,10 m x 7,20 m										360°		ISO	
		11,9 m	16,2 m	20,4 m	24,7 m	29,0 m	33,3 m	37,5 m	40,5 m	45,2 m	50,0 m				
m	t	t	t	t	t	t	t	t	t	t	t	m	m		
3	26,6	26,6	26,6	26,6	-	-	-	-	-	-	-	3	3		
4	26,6	26,6	26,6	26,6	26,6	-	-	-	-	-	-	4	4		
5	26,6	26,6	26,6	26,6	26,6	26,6	-	-	-	-	-	5	5		
6	26,6	26,6	26,6	26,6	26,6	26,6	26,6	-	-	-	-	6	6		
7	26,6	26,6	26,6	26,6	26,6	26,6	26,6	-	-	-	-	7	7		
8	26,6	26,6	26,6	26,6	26,6	26,5	25,1	21,8	-	-	-	8	8		
9	26,6	26,6	26,6	26,6	26,6	25,8	23,6	20,5	17,6	-	-	9	9		
10	26,6	26,6	26,6	26,4	25,1	22,1	19,3	16,7	14,6	-	-	10	10		
12	-	23,3	24,0	23,8	23,2	19,4	17,2	15,1	13,5	10,7	-	12	12		
14	-	18,8	19,0	18,8	18,2	17,1	15,4	13,7	12,3	10,4	-	14	14		
16	-	-	15,5	15,3	14,8	15,2	13,5	12,4	11,3	9,8	-	16	16		
18	-	-	13,0	12,8	13,1	12,7	12,1	11,1	10,4	9,1	-	18	18		
20	-	-	7,3	11,0	11,2	10,7	10,8	10,1	9,4	8,4	-	20	20		
22	-	-	-	9,9	9,7	9,5	9,3	9,2	8,7	7,7	-	22	22		
24	-	-	-	7,3	8,4	8,5	8,1	7,9	7,7	7,1	-	24	24		
26	-	-	-	-	7,5	7,5	7,3	6,9	6,7	6,7	-	26	26		
28	-	-	-	-	5,5	6,6	6,4	6,1	6,1	5,8	-	28	28		
30	-	-	-	-	-	5,9	5,7	5,5	5,4	5,0	-	30	30		
32	-	-	-	-	-	5,3	5,1	5,0	4,7	4,4	-	32	32		
34	-	-	-	-	-	-	4,5	4,5	4,1	3,8	-	34	34		
36	-	-	-	-	-	-	4,0	4,0	3,6	3,3	-	36	36		
38	-	-	-	-	-	-	-	3,6	3,2	2,9	-	38	38		
40	-	-	-	-	-	-	-	2,8	2,8	2,5	-	40	40		
42	-	-	-	-	-	-	-	-	2,5	2,1	-	42	42		
44	-	-	-	-	-	-	-	-	1,9	1,8	-	44	44		
46	-	-	-	-	-	-	-	-	-	1,5	-	46	46		
48	-	-	-	-	-	-	-	-	-	1,3	-	48	48		

20,2 t		8,10 m x 7,20 m										360°		ISO	
		11,9 m	16,2 m	20,4 m	24,7 m	29,0 m	33,3 m	37,5 m	40,5 m	45,2 m	50,0 m				
m	t	t	t	t	t	t	t	t	t	t	t	m	m		
3	26,6	26,6	26,6	26,6	-	-	-	-	-	-	-	3	3		
4	26,6	26,6	26,6	26,6	26,6	-	-	-	-	-	-	4	4		
5	26,6	26,6	26,6	26,6	26,6	26,6	-	-	-	-	-	5	5		
6	26,6	26,6	26,6	26,6	26,6	26,6	26,6	-	-	-	-	6	6		
7	26,6	26,6	26,6	26,6	26,6	26,6	26,6	-	-	-	-	7	7		
8	26,6	26,6	26,6	26,6	26,6	26,5	25,1	21,8	-	-	-	8	8		
9	26,6	26,6	26,6	26,6	26,6	25,8	23,6	20,5	17,6	-	-	9	9		
10	26,6	26,6	26,6	26,4	25,1	22,1	19,3	16,7	14,6	-	-	10	10		
12	-	21,1	21,3	21,1	20,5	19,4	17,2	15,1	13,5	10,7	-	12	12		
14	-	16,6	16,8	16,6	16,3	16,4	15,4	13,7	12,3	10,4	-	14	14		
16	-	-	13,7	13,5	13,8	13,3	13,1	12,4	11,3	9,8	-	16	16		
18	-	-	11,7	11,8	11,5	11,4	11,1	10,7	10,4	9,1	-	18	18		
20	-	-	7,3	10,0	9,8	9,8	9,4	9,3	9,0	8,4	-	20	20		
22	-	-	-	8,6	8,6	8,4	8,3	7,9	7,8	7,6	-	22	22		
24	-	-	-	7,3	7,5	7,3	7,2	6,9	6,8	6,5	-	24	24		
26	-	-	-	-	6,6	6,5	6,2	6,3	5,9	5,6	-	26	26		
28	-	-	-	-	5,5	5,7	5,5	5,5	5,1	4,8	-	28	28		
30	-	-	-	-	-	5,0	4,8	4,8	4,4	4,1	-	30	30		
32	-	-	-	-	-	4,4	4,2	4,2	3,8	3,5	-	32	32		
34	-	-	-	-	-	-	3,7	3,7	3,3	3,0	-	34	34		
36	-	-	-	-	-	-	3,3	3,2	2,8	2,5	-	36	36		
38	-	-	-	-	-	-	-	2,9	2,5	2,1	-	38	38		
40	-	-	-	-	-	-	-	2,1	2,1	1,8	-	40	40		
42	-	-	-	-	-	-	-	-	1,8	1,5	-	42	42		
44	-	-	-	-	-	-	-	-	1,2	1,2	-	44	44		
46	-	-	-	-	-	-	-	-	-	0,9	-	46	46		
48	-	-	-	-	-	-	-	-	-	0,7	-	48	48		



14,2 t		8,10 m x 7,20 m										360°	ISO
	11,9 m	16,2 m	20,4 m	24,7 m	29,0 m	33,3 m	37,5 m	40,5 m	45,2 m	50,0 m			
m	t	t	t	t	t	t	t	t	t	t	t	m	
3	26,6	26,6	26,6	-	-	-	-	-	-	-	-	3	
4	26,6	26,6	26,6	26,6	-	-	-	-	-	-	-	4	
5	26,6	26,6	26,6	26,6	26,6	-	-	-	-	-	-	5	
6	26,6	26,6	26,6	26,6	26,6	26,6	-	-	-	-	-	6	
7	26,6	26,6	26,6	26,6	26,6	26,6	-	-	-	-	-	7	
8	26,6	26,6	26,6	26,6	26,5	25,1	21,8	-	-	-	-	8	
9	26,6	26,6	26,6	26,6	26,6	25,8	23,6	20,5	17,6	-	-	9	
10	23,0	24,2	24,4	24,2	23,0	21,7	19,3	16,7	14,6	-	-	10	
12	-	18,0	18,2	17,9	18,0	17,8	16,4	15,1	13,5	10,7	-	12	
14	-	14,0	14,2	14,5	14,4	14,0	14,0	13,0	12,3	10,4	-	14	
16	-	-	11,8	11,9	11,6	11,7	11,3	11,1	10,7	9,8	-	16	
18	-	-	9,8	9,9	9,9	9,7	9,5	9,1	9,2	8,8	-	18	
20	-	-	7,3	8,3	8,4	8,2	8,0	8,0	7,7	7,4	-	20	
22	-	-	-	7,2	7,2	7,0	6,8	6,8	6,5	6,1	-	22	
24	-	-	-	6,2	6,2	6,0	5,8	5,8	5,5	5,1	-	24	
26	-	-	-	-	5,4	5,2	5,0	5,0	4,6	4,2	-	26	
28	-	-	-	-	4,7	4,5	4,2	4,3	3,9	3,5	-	28	
30	-	-	-	-	-	3,9	3,6	3,6	3,2	2,9	-	30	
32	-	-	-	-	-	3,4	3,1	3,1	2,7	2,4	-	32	
34	-	-	-	-	-	-	2,7	2,7	2,3	1,9	-	34	
36	-	-	-	-	-	-	2,3	2,3	1,9	1,5	-	36	
38	-	-	-	-	-	-	-	1,9	1,5	1,2	-	38	
40	-	-	-	-	-	-	-	1,2	1,2	0,9	-	40	
42	-	-	-	-	-	-	-	-	1,0	-	-	42	



9,0 t		8,10 m x 7,20 m										360°	ISO
	11,9 m	16,2 m	20,4 m	24,7 m	29,0 m	33,3 m	37,5 m	40,5 m	45,2 m	50,0 m			
m	t	t	t	t	t	t	t	t	t	t	t	m	
3	26,6	26,6	26,6	-	-	-	-	-	-	-	-	3	
4	26,6	26,6	26,6	26,6	-	-	-	-	-	-	-	4	
5	26,6	26,6	26,6	26,6	26,6	-	-	-	-	-	-	5	
6	26,6	26,6	26,6	26,6	26,6	26,6	-	-	-	-	-	6	
7	26,6	26,6	26,6	26,6	26,6	26,6	-	-	-	-	-	7	
8	26,6	26,6	26,6	26,6	26,2	24,6	21,8	-	-	-	-	8	
9	23,5	24,7	24,9	24,4	22,8	21,9	20,1	17,6	-	-	-	9	
10	19,5	20,6	20,9	20,6	20,5	19,2	18,0	16,7	14,6	-	-	10	
12	-	15,2	15,5	15,9	15,6	15,5	14,6	14,0	13,1	10,7	-	12	
14	-	11,8	12,3	12,4	12,4	12,2	12,0	11,2	10,9	10,2	-	14	
16	-	-	9,9	10,0	10,0	9,9	9,6	9,6	9,0	8,3	-	16	
18	-	-	8,1	8,3	8,3	8,1	7,8	7,8	7,5	6,8	-	18	
20	-	-	6,8	6,9	6,9	6,7	6,4	6,5	6,1	5,5	-	20	
22	-	-	-	5,8	5,8	5,6	5,4	5,4	5,0	4,5	-	22	
24	-	-	-	4,9	4,9	4,7	4,4	4,5	4,1	3,7	-	24	
26	-	-	-	-	4,2	3,9	3,7	3,7	3,3	3,0	-	26	
28	-	-	-	-	3,6	3,3	3,1	3,1	2,7	2,4	-	28	
30	-	-	-	-	-	2,8	2,5	2,6	2,2	1,8	-	30	
32	-	-	-	-	-	2,3	2,1	2,1	1,7	1,4	-	32	
34	-	-	-	-	-	-	1,7	1,7	1,3	1,0	-	34	
36	-	-	-	-	-	-	1,4	1,4	1,0	-	-	36	
38	-	-	-	-	-	-	-	1,1	0,7	-	-	38	

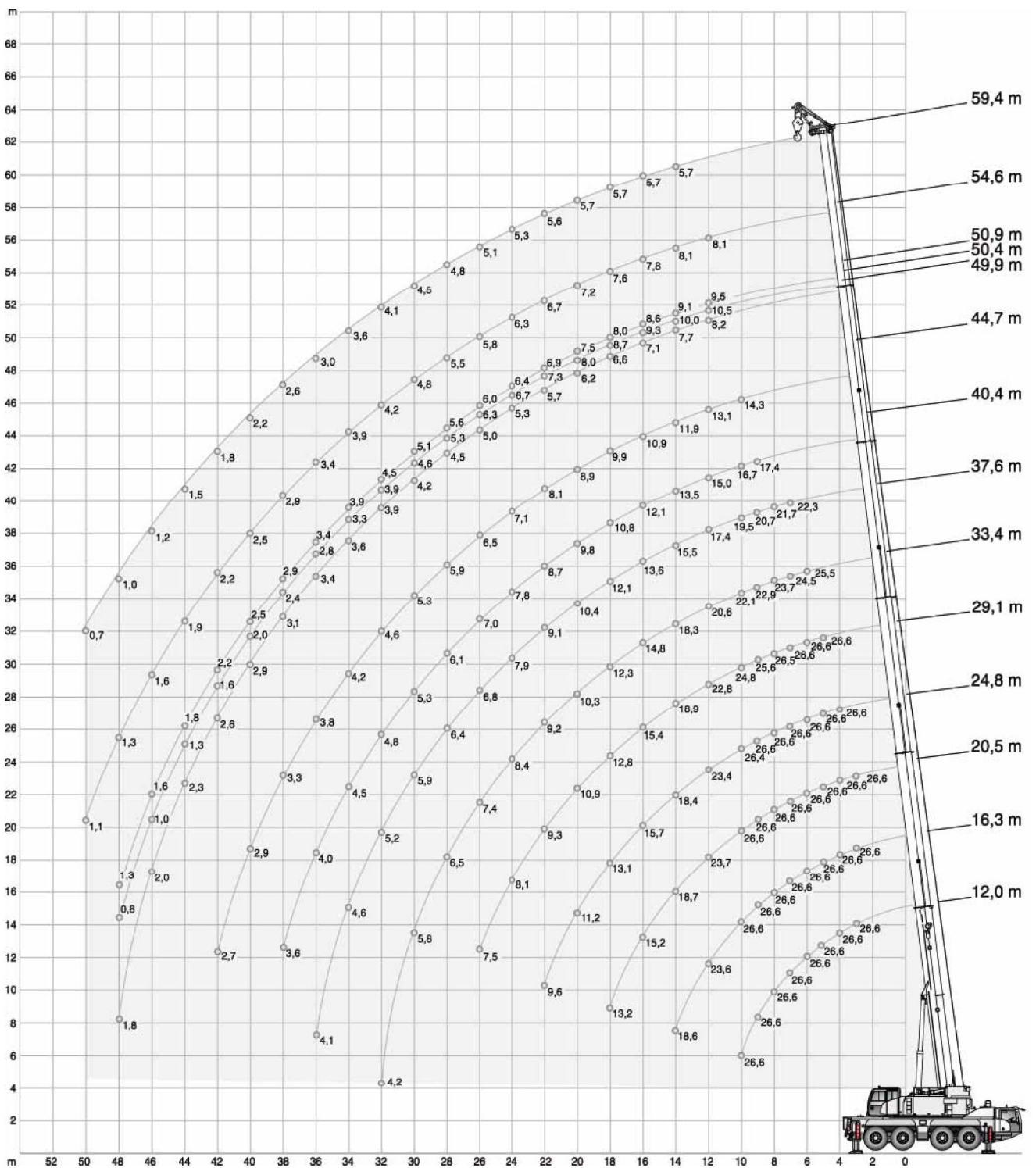
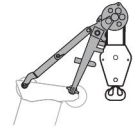

6,1 t		8,10 m x 7,20 m										360°		ISO	
		11,9m	16,2m	20,4m	24,7m	29,0m	33,3m	37,5m	40,5m	45,2m	50,0m				
m	t	t	t	t	t	t	t	t	t	t	t	m	m		
3	26,6	26,6	26,6	26,6	-	-	-	-	-	-	-	3	3		
4	26,6	26,6	26,6	26,6	26,6	-	-	-	-	-	-	4	4		
5	26,6	26,6	26,6	26,6	26,6	26,6	-	-	-	-	-	5	5		
6	26,6	26,6	26,6	26,6	26,6	26,6	26,6	-	-	-	-	6	6		
7	26,6	26,6	26,6	26,6	26,6	26,6	26,3	-	-	-	-	7	7		
8	26,4	26,6	26,6	26,6	25,9	24,3	23,1	21,1	-	-	-	8	8		
9	21,2	22,4	22,7	22,1	21,6	19,9	18,6	17,5	-	-	-	9	9		
10	17,6	18,7	18,9	19,1	18,8	17,5	16,8	15,6	14,6	-	-	10	10		
12	-	13,7	14,3	14,4	14,4	14,2	13,5	12,4	12,0	10,7	-	12	12		
14	-	10,5	11,1	11,2	11,2	11,0	10,7	10,5	9,6	8,8	-	14	14		
16	-	-	8,8	8,9	8,9	8,9	8,7	8,5	7,8	7,0	-	16	16		
18	-	-	7,2	7,2	7,3	7,0	6,8	6,8	6,3	5,7	-	18	18		
20	-	-	6,0	6,0	6,0	5,8	5,6	5,6	5,1	4,5	-	20	20		
22	-	-	-	5,0	5,0	4,8	4,5	4,5	4,1	3,6	-	22	22		
24	-	-	-	4,2	4,2	3,9	3,7	3,7	3,3	2,8	-	24	24		
26	-	-	-	-	3,5	3,3	3,0	3,0	2,6	2,2	-	26	26		
28	-	-	-	-	2,9	2,7	2,4	2,5	2,1	1,7	-	28	28		
30	-	-	-	-	-	2,2	2,0	2,0	1,6	1,2	-	30	30		
32	-	-	-	-	-	1,8	1,6	1,6	1,2	0,8	-	32	32		
34	-	-	-	-	-	-	1,2	1,2	0,8	-	-	34	34		
36	-	-	-	-	-	-	0,9	0,9	-	-	-	36	36		



4,5 t		8,10 m x 7,20 m										360°		ISO	
		11,9m	16,2m	20,4m	24,7m	29,0m	33,3m	37,5m	40,5m	45,2m	50,0m				
m	t	t	t	t	t	t	t	t	t	t	t	m	m		
3	26,6	26,6	26,6	26,6	-	-	-	-	-	-	-	3	3		
4	26,6	26,6	26,6	26,6	26,6	-	-	-	-	-	-	4	4		
5	26,6	26,6	26,6	26,6	26,6	26,6	-	-	-	-	-	5	5		
6	26,6	26,6	26,6	26,6	26,6	26,6	26,6	-	-	-	-	6	6		
7	26,6	26,6	26,6	26,6	26,6	26,6	25,1	-	-	-	-	7	7		
8	24,8	26,1	26,3	24,5	23,4	21,8	20,3	-	-	-	-	8	8		
9	19,9	21,1	21,4	20,9	20,4	18,9	18,0	16,4	-	-	-	9	9		
10	16,4	17,6	17,8	18,3	17,8	17,1	16,1	14,7	13,7	-	-	10	10		
12	-	12,8	13,4	13,5	13,5	13,2	12,4	12,1	11,1	10,1	-	12	12		
14	-	9,7	10,3	10,4	10,4	10,2	9,9	9,6	8,7	8,0	-	14	14		
16	-	-	8,2	8,2	8,2	8,0	7,8	7,8	7,0	6,3	-	16	16		
18	-	-	6,6	6,7	6,7	6,5	6,2	6,2	5,7	5,0	-	18	18		
20	-	-	5,4	5,5	5,5	5,3	5,0	5,0	4,5	3,9	-	20	20		
22	-	-	-	4,5	4,5	4,3	4,0	4,1	3,6	3,0	-	22	22		
24	-	-	-	3,7	3,7	3,5	3,2	3,3	2,9	2,3	-	24	24		
26	-	-	-	-	3,1	2,8	2,6	2,6	2,2	1,8	-	26	26		
28	-	-	-	-	2,6	2,3	2,1	2,1	1,7	1,3	-	28	28		
30	-	-	-	-	-	1,9	1,6	1,6	1,2	0,9	-	30	30		
32	-	-	-	-	-	1,5	1,2	1,2	0,9	-	-	32	32		
34	-	-	-	-	-	-	0,9	0,9	-	-	-	34	34		









25,2 t		8,10 m x 7,20 m														360°		ISO	
																			
		12,0m	16,3m	20,5m	24,8m	29,1m	33,4m	37,6m	40,4m	44,7m	49,9m	50,4m	50,9m	54,6m	59,4m				
m	t	t	t	t	t	t	t	t	t	t	t	t	t	t	t	m	m	m	m
3	26,6	26,6	26,6	-	-	-	-	-	-	-	-	-	-	-	-	3	3	3	3
4	26,6	26,6	26,6	26,6	-	-	-	-	-	-	-	-	-	-	-	4	4	4	4
5	26,6	26,6	26,6	26,6	26,6	-	-	-	-	-	-	-	-	-	-	5	5	5	5
6	26,6	26,6	26,6	26,6	26,6	25,5	-	-	-	-	-	-	-	-	-	6	6	6	6
7	26,6	26,6	26,6	26,6	26,6	24,5	22,3	-	-	-	-	-	-	-	-	7	7	7	7
8	26,6	26,6	26,6	26,6	26,5	23,7	21,7	-	-	-	-	-	-	-	-	8	8	8	8
9	26,6	26,6	26,6	26,6	25,6	22,9	20,7	17,4	-	-	-	-	-	-	-	9	9	9	9
10	26,6	26,6	26,6	26,4	24,8	22,1	19,5	16,7	14,3	-	-	-	-	-	-	10	10	10	10
12	-	23,6	23,7	23,4	22,8	20,6	17,4	15,0	13,1	8,2	10,5	9,5	8,1	-	-	12	12	12	12
14	-	18,6	18,7	18,4	18,9	18,3	15,5	13,5	11,9	7,7	10,0	9,1	8,1	5,7	-	14	14	14	14
16	-	-	15,2	15,7	15,4	14,8	13,6	12,1	10,9	7,1	9,3	8,6	7,8	5,7	-	16	16	16	16
18	-	-	13,2	13,1	12,8	12,3	12,1	10,8	9,9	6,6	8,7	8,0	7,6	5,7	-	18	18	18	18
20	-	-	-	11,2	10,9	10,3	10,4	9,8	8,9	6,2	8,0	7,5	7,2	5,7	-	20	20	20	20
22	-	-	-	9,6	9,3	9,2	9,1	8,7	8,1	5,7	7,3	6,9	6,7	5,6	-	22	22	22	22
24	-	-	-	5,8	8,1	8,4	7,9	7,8	7,1	5,3	6,7	6,4	6,3	5,3	-	24	24	24	24
26	-	-	-	-	7,5	7,4	6,8	7,0	6,5	5,0	6,3	6,0	5,8	5,1	-	26	26	26	26
28	-	-	-	-	5,1	6,5	6,4	6,1	5,9	4,6	5,3	5,6	5,5	4,8	-	28	28	28	28
30	-	-	-	-	-	5,8	5,9	5,3	5,3	4,2	4,6	5,1	4,8	4,5	-	30	30	30	30
32	-	-	-	-	-	4,2	5,2	4,8	4,6	3,9	3,9	4,5	4,2	4,1	-	32	32	32	32
34	-	-	-	-	-	-	4,6	4,5	4,2	3,6	3,3	3,9	3,9	3,6	-	34	34	34	34
36	-	-	-	-	-	-	4,1	4,0	3,8	3,4	2,8	3,4	3,4	3,0	-	36	36	36	36
38	-	-	-	-	-	-	-	3,6	3,3	3,1	2,4	2,9	2,9	2,6	-	38	38	38	38
40	-	-	-	-	-	-	-	3,2	2,9	2,9	2,0	2,5	2,5	2,2	-	40	40	40	40
42	-	-	-	-	-	-	-	-	-	2,7	2,6	1,6	2,2	1,8	-	42	42	42	42
44	-	-	-	-	-	-	-	-	-	2,3	2,3	1,3	1,8	1,5	-	44	44	44	44
46	-	-	-	-	-	-	-	-	-	-	2,0	1,0	1,6	1,2	-	46	46	46	46
48	-	-	-	-	-	-	-	-	-	-	1,8	0,8	1,3	1,0	-	48	48	48	48
50	-	-	-	-	-	-	-	-	-	-	-	-	-	1,1	0,7	50	50	50	50

20,2 t		8,10 m x 7,20 m														360°		ISO	
																			
		12,0m	16,3m	20,5m	24,8m	29,1m	33,4m	37,6m	40,4m	44,7m	49,9m	50,4m	50,9m	54,6m	59,4m				
m	t	t	t	t	t	t	t	t	t	t	t	t	t	t	t	m	m	m	m
3	26,6	26,6	26,6	-	-	-	-	-	-	-	-	-	-	-	-	3	3	3	3
4	26,6	26,6	26,6	26,6	-	-	-	-	-	-	-	-	-	-	-	4	4	4	4
5	26,6	26,6	26,6	26,6	26,6	-	-	-	-	-	-	-	-	-	-	5	5	5	5
6	26,6	26,6	26,6	26,6	26,6	25,5	-	-	-	-	-	-	-	-	-	6	6	6	6
7	26,6	26,6	26,6	26,6	26,6	24,5	22,3	-	-	-	-	-	-	-	-	7	7	7	7
8	26,6	26,6	26,6	26,6	26,5	23,7	21,7	-	-	-	-	-	-	-	-	8	8	8	8
9	26,6	26,6	26,6	26,6	25,6	22,9	20,7	17,4	-	-	-	-	-	-	-	9	9	9	9
10	26,6	26,6	26,6	26,4	24,8	22,1	19,5	16,7	14,3	-	-	-	-	-	-	10	10	10	10
12	-	20,9	21,0	20,7	20,6	20,6	17,4	15,0	13,1	8,2	10,5	9,5	8,1	-	-	12	12	12	12
14	-	16,3	16,4	17,0	16,7	16,1	15,5	13,5	11,9	7,7	10,0	9,1	8,1	5,7	-	14	14	14	14
16	-	-	13,9	13,8	13,5	12,9	12,8	12,1	10,9	7,1	9,3	8,6	7,8	5,7	-	16	16	16	16
18	-	-	11,6	11,5	11,2	11,1	11,0	10,3	9,9	6,6	8,7	8,0	7,6	5,7	-	18	18	18	18
20	-	-	-	9,7	9,4	9,7	9,2	8,9	8,5	6,2	8,0	7,5	7,2	5,7	-	20	20	20	20
22	-	-	-	8,3	8,5	8,4	7,9	8,0	7,6	5,7	7,3	6,9	6,7	5,6	-	22	22	22	22
24	-	-	-	5,8	7,5	7,2	7,2	6,9	6,8	5,3	6,1	6,4	6,3	5,3	-	24	24	24	24
26	-	-	-	-	6,6	6,3	6,4	5,9	5,9	5,0	5,1	5,7	5,4	5,1	-	26	26	26	26
28	-	-	-	-	4,1	5,8	5,6	5,5	5,3	4,6	4,3	4,9	4,8	4,5	-	28	28	28	28
30	-	-	-	-	-	5,2	4,9	4,8	4,6	4,2	3,6	4,2	4,2	3,9	-	30	30	30	30
32	-	-	-	-	-	3,3	4,5	4,2	4,0	3,9	3,0	3,6	3,6	3,2	-	32	32	32	32
34	-	-	-	-	-	-	4,0	3,7	3,5	3,5	2,5	3,0	3,1	2,7	-	34	34	34	34
36	-	-	-	-	-	-	3,6	3,2	3,3	3,0	2,0	2,6	2,6	2,3	-	36	36	36	36
38	-	-	-	-	-	-	-	2,8	2,9	2,6	1,6	2,2	2,2	1,9	-	38	38	38	38
40	-	-	-	-	-	-	-	2,5	2,5	2,2	1,3	1,8	1,8	1,5	-	40	40	40	40
42	-	-	-	-	-	-	-	-	2,2	1,9	1,0	1,5	1,5	1,2	-	42	42	42	42
44	-	-	-	-	-	-	-	-	1,7	1,6	-	1,2	1,2	0,9	-	44	44	44	44
46	-	-	-	-	-	-	-	-	-	1,4	-	1,0	1,0	-	-	46	46	46	46
48	-	-	-	-	-	-	-	-	-	1,2	-	0,8	0,7	-	-	48	48	48	48

14,2 t		8,10 m x 7,20 m														360°		ISO	
																			
		12,0m	16,3m	20,5m	24,8m	29,1m	33,4m	37,6m	40,4m	44,7m	49,9m	50,4m	50,9m	54,6m	59,4m				
m	t	t	t	t	t	t	t	t	t	t	t	t	t	t	t	m			
3	26,6	26,6	26,6	-	-	-	-	-	-	-	-	-	-	-	-	3			
4	26,6	26,6	26,6	26,6	-	-	-	-	-	-	-	-	-	-	-	4			
5	26,6	26,6	26,6	26,6	26,6	-	-	-	-	-	-	-	-	-	-	5			
6	26,6	26,6	26,6	26,6	26,6	25,5	-	-	-	-	-	-	-	-	-	6			
7	26,6	26,6	26,6	26,6	26,6	24,5	22,3	-	-	-	-	-	-	-	-	7			
8	26,6	26,6	26,6	26,6	26,5	23,7	21,7	-	-	-	-	-	-	-	-	8			
9	26,6	26,6	26,6	26,6	25,6	22,9	20,7	17,4	-	-	-	-	-	-	-	9			
10	23,1	24,1	24,2	23,8	22,5	22,1	19,5	16,7	14,3	-	-	-	-	-	-	10			
12	-	17,8	17,9	18,5	18,1	17,5	16,5	15,0	13,1	8,2	10,5	9,5	8,1	-	-	12			
14	-	14,1	14,5	14,5	14,1	13,9	13,3	12,6	11,9	7,7	10,0	9,1	8,1	5,7	-	14			
16	-	-	11,7	11,7	11,3	11,4	11,2	10,7	10,0	7,1	9,3	8,6	7,8	5,7	-	16			
18	-	-	9,7	9,6	9,8	9,7	9,5	9,3	8,8	6,6	8,3	8,0	7,6	5,7	-	18			
20	-	-	-	8,3	8,4	8,1	8,2	7,7	7,7	6,2	6,9	7,5	7,0	5,7	-	20			
22	-	-	-	7,3	7,2	7,2	7,0	6,9	6,7	5,7	5,7	6,3	5,8	5,6	-	22			
24	-	-	-	5,8	6,2	6,3	6,1	5,9	5,7	5,3	4,7	5,3	5,2	4,6	-	24			
26	-	-	-	-	5,6	5,5	5,4	5,1	4,8	4,8	3,8	4,4	4,4	3,8	-	26			
28	-	-	-	-	3,5	4,7	4,6	4,3	4,4	4,1	3,1	3,7	3,7	3,1	-	28			
30	-	-	-	-	-	4,1	4,0	3,7	3,8	3,5	2,5	3,0	3,1	2,6	-	30			
32	-	-	-	-	-	3,3	3,5	3,4	3,2	2,9	1,9	2,5	2,5	2,1	-	32			
34	-	-	-	-	-	-	3,0	3,0	2,7	2,5	1,5	2,0	2,1	1,7	-	34			
36	-	-	-	-	-	-	2,6	2,6	2,3	2,1	1,1	1,6	1,6	1,3	-	36			
38	-	-	-	-	-	-	-	2,3	2,0	1,7	0,7	1,3	1,3	0,9	-	38			
40	-	-	-	-	-	-	-	1,7	1,7	1,4	-	1,0	1,0	-	-	40			
42	-	-	-	-	-	-	-	-	1,4	1,1	-	-	-	-	-	42			
44	-	-	-	-	-	-	-	-	0,9	0,9	-	-	-	-	-	44			

9,0 t		8,10 m x 7,20 m														360°		ISO	
																			
		12,0m	16,3m	20,5m	24,8m	29,1m	33,4m	37,6m	40,4m	44,7m	49,9m	50,4m	50,9m	54,6m	59,4m				
m	t	t	t	t	t	t	t	t	t	t	t	t	t	t	t	m			
3	26,6	26,6	26,6	-	-	-	-	-	-	-	-	-	-	-	-	3			
4	26,6	26,6	26,6	26,6	-	-	-	-	-	-	-	-	-	-	-	4			
5	26,6	26,6	26,6	26,6	26,6	-	-	-	-	-	-	-	-	-	-	5			
6	26,6	26,6	26,6	26,6	26,6	25,5	-	-	-	-	-	-	-	-	-	6			
7	26,6	26,6	26,6	26,6	26,6	24,5	22,3	-	-	-	-	-	-	-	-	7			
8	26,6	26,6	26,6	26,6	25,7	23,7	21,7	-	-	-	-	-	-	-	-	8			
9	26,7	24,6	24,8	24,0	23,6	21,6	20,3	17,4	-	-	-	-	-	-	-	9			
10	19,6	20,5	20,6	21,2	20,5	18,8	17,8	16,7	14,3	-	-	-	-	-	-	10			
12	-	15,4	15,8	15,7	15,4	15,4	14,0	13,4	12,5	8,2	10,5	9,5	8,1	-	-	12			
14	-	11,9	12,3	12,2	12,3	12,2	11,7	11,3	10,5	7,7	9,8	9,1	8,1	5,7	-	14			
16	-	-	9,8	10,0	10,2	9,9	9,8	9,4	9,1	7,1	7,8	8,5	7,8	5,7	-	16			
18	-	-	8,0	8,5	8,3	8,5	8,1	8,1	7,8	6,6	6,3	7,0	6,6	5,7	-	18			
20	-	-	-	7,0	7,1	7,0	6,9	6,7	6,4	6,2	5,1	5,7	5,6	4,9	-	20			
22	-	-	-	6,0	6,0	5,9	5,8	5,5	5,6	5,2	4,1	4,7	4,5	3,9	-	22			
24	-	-	-	5,1	5,1	5,0	4,9	4,8	4,6	4,3	3,2	3,8	3,7	3,1	-	24			
26	-	-	-	-	4,4	4,2	4,1	4,2	3,9	3,6	2,5	3,1	3,0	2,4	-	26			
28	-	-	-	-	3,5	3,6	3,5	3,5	3,2	2,9	1,9	2,5	2,4	1,8	-	28			
30	-	-	-	-	-	3,1	2,9	3,0	2,7	2,4	1,4	1,9	1,9	1,4	-	30			
32	-	-	-	-	-	2,6	2,5	2,5	2,2	1,9	0,9	1,5	1,5	1,0	-	32			
34	-	-	-	-	-	-	2,1	2,1	1,8	1,5	-	1,1	1,1	-	-	34			
36	-	-	-	-	-	-	1,7	1,7	1,4	1,2	-	0,7	0,8	-	-	36			
38	-	-	-	-	-	-	-	1,5	1,1	0,9	-	-	-	-	-	38			
40	-	-	-	-	-	-	-	0,9	0,9	-	-	-	-	-	-	40			

6,1 t		8,10 m x 7,20 m														360°		ISO	
																			
		12,0m	16,3m	20,5m	24,8m	29,1m	33,4m	37,6m	40,4m	44,7m	49,9m	50,4m	50,9m	54,6m	59,4m				
m	t	t	t	t	t	t	t	t	t	t	t	t	t	t	t	m	t		
3	26,6	26,6	26,6	-	-	-	-	-	-	-	-	-	-	-	-	3	26,6		
4	26,6	26,6	26,6	26,6	-	-	-	-	-	-	-	-	-	-	-	4	26,6		
5	26,6	26,6	26,6	26,6	26,6	-	-	-	-	-	-	-	-	-	-	5	26,6		
6	26,6	26,6	26,6	26,6	26,6	25,5	-	-	-	-	-	-	-	-	-	6	26,6		
7	26,6	26,6	26,6	26,6	26,6	24,5	22,3	-	-	-	-	-	-	-	-	7	26,6		
8	26,6	26,6	26,5	25,6	24,7	22,8	21,3	-	-	-	-	-	-	-	-	8	26,6		
9	21,4	22,4	22,5	22,4	21,4	19,7	18,4	17,2	-	-	-	-	-	-	-	9	21,4		
10	17,7	18,6	19,5	19,4	18,6	17,5	16,0	15,4	14,3	-	-	-	-	-	-	10	17,7		
12	-	13,9	14,3	14,2	14,2	13,8	13,0	12,4	11,5	8,2	10,5	9,5	8,1	-	-	12	-		
14	-	10,7	11,0	11,1	11,4	11,0	10,9	10,1	9,7	7,7	8,4	9,1	8,1	5,7	-	14	-		
16	-	-	8,7	9,2	9,1	9,2	8,8	8,8	8,2	7,1	6,6	7,3	6,9	5,7	-	16	-		
18	-	-	7,3	7,5	7,6	7,4	7,3	7,1	6,7	6,5	5,2	5,9	5,7	5,0	-	18	-		
20	-	-	-	6,2	6,3	6,1	6,0	5,8	5,8	5,3	4,1	4,7	4,5	3,9	-	20	-		
22	-	-	-	5,2	5,3	5,1	5,0	4,7	4,3	3,2	3,8	3,6	3,0	2,2	-	22	-		
24	-	-	-	4,4	4,4	4,3	4,1	4,2	3,9	3,5	2,4	3,0	2,9	2,2	-	24	-		
26	-	-	-	-	3,8	3,6	3,4	3,5	3,2	2,9	1,8	2,4	2,2	1,6	-	26	-		
28	-	-	-	-	3,2	3,0	2,8	2,9	2,6	2,3	1,3	1,8	1,7	1,2	-	28	-		
30	-	-	-	-	-	2,5	2,3	2,4	2,1	1,8	0,8	1,4	1,3	0,7	-	30	-		
32	-	-	-	-	-	2,1	1,9	1,9	1,7	1,4	-	0,9	0,9	-	-	32	-		
34	-	-	-	-	-	-	1,6	1,6	1,3	1,0	-	-	-	-	-	34	-		
36	-	-	-	-	-	-	1,3	1,3	1,0	-	-	-	-	-	-	36	-		
38	-	-	-	-	-	-	-	1,0	-	-	-	-	-	-	-	38	-		

4,5 t		8,10 m x 7,20 m														360°		ISO	
																			
		12,0m	16,3m	20,5m	24,8m	29,1m	33,4m	37,6m	40,4m	44,7m	49,9m	50,4m	50,9m	54,6m	59,4m				
m	t	t	t	t	t	t	t	t	t	t	t	t	t	t	t	m	t		
3	26,6	26,6	26,6	-	-	-	-	-	-	-	-	-	-	-	-	3	26,6		
4	26,6	26,6	26,6	26,6	-	-	-	-	-	-	-	-	-	-	-	4	26,6		
5	26,6	26,6	26,6	26,6	26,6	-	-	-	-	-	-	-	-	-	-	5	26,6		
6	26,6	26,6	26,6	26,6	26,6	25,5	-	-	-	-	-	-	-	-	-	6	26,6		
7	26,6	26,6	26,6	26,6	26,3	24,5	22,3	-	-	-	-	-	-	-	-	7	26,6		
8	25,1	26,2	26,0	24,1	23,6	21,5	20,2	-	-	-	-	-	-	-	-	8	25,1		
9	20,1	21,1	21,2	21,7	20,2	18,9	17,2	16,2	-	-	-	-	-	-	-	9	20,1		
10	16,5	17,6	18,3	18,3	17,5	16,7	15,7	14,2	13,2	-	-	-	-	-	-	10	16,5		
12	-	13,0	13,4	13,4	13,6	13,3	12,5	11,7	10,6	8,2	9,8	9,5	8,1	-	-	12	-		
14	-	9,8	10,2	10,6	10,6	10,3	10,3	9,9	9,2	7,7	7,5	8,3	7,6	5,7	-	14	-		
16	-	-	8,3	8,5	8,6	8,5	8,4	8,0	7,4	7,1	5,9	6,6	6,4	5,7	-	16	-		
18	-	-	6,7	6,9	7,0	6,9	6,8	6,5	6,5	5,8	4,6	5,3	5,0	4,3	-	18	-		
20	-	-	-	5,7	5,7	5,6	5,5	5,6	5,3	4,7	3,5	4,1	3,9	3,3	-	20	-		
22	-	-	-	4,7	4,8	4,7	4,5	4,6	4,3	3,7	2,6	3,2	3,1	2,4	-	22	-		
24	-	-	-	3,9	4,0	3,9	3,7	3,7	3,4	3,0	1,9	2,5	2,4	1,8	-	24	-		
26	-	-	-	-	3,4	3,2	3,0	3,1	2,8	2,4	1,3	1,9	1,8	1,2	-	26	-		
28	-	-	-	-	2,8	2,6	2,5	2,5	2,2	1,9	0,8	1,4	1,3	0,7	-	28	-		
30	-	-	-	-	-	2,2	2,0	2,0	1,7	1,5	-	1,0	0,9	-	-	30	-		
32	-	-	-	-	-	1,8	1,6	1,6	1,3	1,1	-	-	-	-	-	32	-		
34	-	-	-	-	-	-	1,3	1,3	1,0	0,7	-	-	-	-	-	34	-		
36	-	-	-	-	-	-	1,0	1,0	-	-	-	-	-	-	-	36	-		
38	-	-	-	-	-	-	-	0,7	-	-	-	-	-	-	-	38	-		

Basic equipment

Carrier

Engine 340-4	MTU; Output 340 kW (462 HP) at 1700 1/min, torque 2200 Nm at 1300 1/min; certifications in accordance with EURO MOT 4, TIER 4, CARB; Stainless steel exhaust system with certified spark arrestor.
Fuel tank 400	400 l; Fuel: Diesel.
Transmission AS12INT	ZF AS-Tronic; Automated gearbox with integrated hydraulic retarder, 12 forward speeds and 2 reverse; 2-stage transfer case with switchable off-road gear and switchable longitudinal lock.
Axles 8 x 6 x 8	8 x 6 x 8; 4 axles, axles 1, 2, 4 driven and equipped with selectable transverse lock; All axles steered.
Suspension	Hydropneumatic suspension with axle load compensation; Hydraulically lockable; Manual or automatic levelling alternatively.
Steering	Dual circuit hydro servocom steering with emergency steering pump; Active rear axle steering (axles 3 and 4) with 6 different steering programs.
Brakes	Pneumatic dual circuit service brake with antilock system, acting on all wheels; Disc brakes; Additional exhaust brake and constant throttle valve; Spring-loaded parking brake.
Wheels 38595 170F	385/95R25 170F (14.00R25); Steel rims 9,50-25/1,7" CR.
Cab carrier 2550	Type 2.55 m; Adjustable driver seat with seat heating, armrests and pneumatic suspension; Steering wheel height and tilt adjustable; Power door windows; Tinted glass; Air condition and radio preparation; 2 integrated rotary beacons; Storage area.
Heating engine-dependent 12	Engine-dependent warm water heating with 12 kW heating power.
Drive lights	With low beam, upper beam, daytime running lights.
Tempomat	Automatic speed control including automatic brake control.
Electronic immobiliser system	Prevents uncontrolled carrier mobilisation; Incl. 2 electronic keys and 4 ignition keys.
Miscellaneous	Ascendancies; Pneumatic tire filling plug.

Crane

Telescopic boom HA50	11.9 m - 50.0 m; Single cylinder telescoping system, manual or automatic telescoping alternatively; Attachments for all equipment and extensions; 5 sheaves integrated in boom head for max. capacity of 64.5 t.
Counterweight EG21	20.2 t, 5 pieces; Automatic rigging system; Expandable to max. 25.2 t; 20.2 t can be carried on board as standard; 4.5 t fixed at crane tail.
Outriggers	H-4 Point design; Vertical and horizontal movement fully hydraulic; Manual or automatic levelling alternatively on both sides of carrier; 4 outrigger bases.
Outrigger basis monitoring	Surveillance of each outrigger beam for visual comparison with the programmed outrigger basis; Displayed in LMI crane cab (Attention – there is no automatic linkage with the LMI system).
Outrigger pads 028	4 outrigger pads A = 0.28 m ² with transport position at vertical cylinder.
Boom luffing	Single luffing cylinder with automatic lowering brake valve.
Rotary drive	Single slewing gear unit with spring-loaded multi-disc brake.
H1	Hoist with spring-loaded multi-disc brake; Resolver (hoist rotation indicator).
Engine 129-4	MTU; Output 129 kW (175 HP) at 2200 1/min, torque 750 Nm at 1200 1/min; certifications in accordance with EURO MOT 4, TIER 4, CARB; Exhaust system cpl. stainless steel, incl. spark arrestor.
Fuel tank 200	200 l; Fuel: Diesel.
Drive	Hydraulic system with power control; Hydraulic oil cooler.
Control system	Enabling 4 simultaneous working movements; Electric pilot controls via 2 two-axis joysticks.
Operator aids	IC-1, with integrated load moment indicator acc. EN13000; Colour display; Displaying of current operating conditions, load charts, fault indicator; Signal lights indicating LMI-load; Crane data logger.
Working range limiter	Displaying and programmability of the work range limits by IC-1.
Cab crane 0875	Type 0.875 m; Tilt variable 20°; Seat heating; Fold-out front window; Extendable side and foldable front pedestal; Handrails; Tinted safety glass; Pull-down sun visor and light curtains; Air condition and radio preparation.
Heating engine-dependent 12	Engine-dependent warm water heating with 12 kW heating power.

Diverse

Illumination	1 x adjustable for work prefield at crane cab, 4 x for outriggers.
Rotary beacons 2	2 x integrated on carrier cab, 2 x disconnectable on crane tail.
Contour safety marking	Continuous, yellow reflecting bands at carrier sides and tail.
Stepladder	Loose stepladder for misc assembly work; Incl. transport storage.

Options

Carrier

Axles 8 x 8 x 8	8 x 8 x 8; All 4 axles steered and permanently driven and equipped with selectable transverse lock.
Counterweight „b“ transport storage on carrier tail	Support frame for storing counterweight „b“ à 2.9 t on carrier tail; Required to carry 9.0 t counterweight on board.
Wheels 44595 174F	445/95R25 174F (16.00R25); Steel rims 11,00-25/1,7" CR.
Wheels 52580 179E	525/80R25 179E (20.50R25); Steel rims 17,00-25/1,7" CR; Incl. carrier broadening to 2.75 m.
Auxiliary heating engine independent carrier 10	Auxiliary, engine independent Diesel heating system with 10 kW heating power; With timer; Switchable between engine block and carrier cab.
Air condition carrier 7	Air condition for carrier cab with 7 kW cooling power.

Crane

Telescopic boom HA60	12.0 m - 59.4 m; Single cylinder telescoping system, automatic telescoping; Attachments for all equipment and extensions; 5 sheaves integrated in boom head for max. capacity of 64.5 t.
Remote control RK S1V	Full control of rigging and crane movements via wireless remote control.
H2X	Heavy lift attachment stage 1; 2-sheave; Dis-/connectable; For total 7 sheaves at boom head and max. capacity of 80 t.
Counterweight NEG21	2. hoist; Spring-loaded multi-disc brake; Resolver (hoist rotation indicator); Incl. quick couplings and transport storage; Self-rigging; Enables 2-hook operation with all extensions.
Additional counterweight EG	Version for countries with special road regulations; Enables self downrigging < 40 t total weight and axle loads < 12 t; Total 20.7 t à 6 pieces; Automatic rigging system, expandable to max. 25.4 t; Individual technical verification required.
Additional counterweight NEG	5.0 t, 2 pieces; For max. 25.2 t à 7 pieces; Only in combination with counterweight EG21.
Quick connection HA2	4.7 t, 1 piece; For max. 25.4 t à 7 pieces; Only in combination with counterweight NEG21.
Outrigger load indicator	Hydraulic bolt extractors and hydraulic and electric quick couplings for fast (dis-) assembly; Incl. transport storage for luffing cylinder.
Moving out of crane cab	Displayed in LMI crane cab.
Auxiliary heating engine independent crane 5	Control of carrier out of crane cab, enables machine moving when rigged, possible even under load.
Air condition crane 7	Auxiliary, engine independent Diesel heating system with 5 kW heating power; With timer and remote start; Switchable between engine block and carrier cab.
	Air condition in crane cab with 7 kW cooling power.

Extensions

HAV19	10 m / 19 m; Double folding swing-away jib, manual offset 20° / 40°; 1-sheave head; Incl. transport storage; Includes HAV10; Operation with HA or VA.
HAV27	27 m; Variable extension with swing-away jib, manual offset 20° / 40°; 1-sheave head; Incl. transport storage; Includes HAV19.
HAV-HY	Hydraulic, stepless offset 0°-40°, instead of the manual offset; For HAV10, respectively HAV19 and HAV27.
MSF2	1.5 m; Fixed assembly jib, 2-sheaves for max. capacity 26.6 t; Incl. transport storage at boom head.
R1	Swing-away rooster sheave; Incl. transport storage; For single-reeving operation with elevated hook height.

Diverse

Refinery package 2M	Engine emergency stop device, with air shut-off damper, for carrier and crane.
Dolly preparation 4PV	4-point support brackets enable individual positioning of a dolly; Incl. freewheel for slewing gear unit and luffing cylinder, quick couplings for brake air and electrics; Dolly and dollyadapter are not included.
Hook block 100-7-18-D	100-7-18-D (750 kg); Hook block with ramshorn hook; white with red signal stripes.
Hook block 80-5-18-D	80-5-18-D (650 kg); Hook block with ramshorn hook; white with red signal stripes.
Hook block 80-5-18-E	80-5-18-E (650 kg); Hook block with single hook; white with red signal stripes.
Hook block 50-3-18-D	50-3-18-D (550 kg); Hook block with ramshorn hook; white with red signal stripes.
Hook block 50-3-18-E	50-3-18-E (550 kg); Hook block with single hook; white with red signal stripes.
Hook block 20-1-18-E	20-1-18-E (300 kg); Hook block with single hook; white with red signal stripes.
Hook 8-0V-18-E	8-0V-18-E (170 kg); Single hook with vertical swivel; red.

Basisausstattung

Fahrgestell

Motor 340-4	MTU; Leistung 340 kW (462 PS) bei 1700 1/min, Drehmoment 2200 Nm bei 1300 1/min, zertifiziert nach EURO MOT 4, TIER 4, CARB; Abgasanlage aus Edelstahl mit Funkenfängerzertifikat.
Kraftstoffbehälter 400	400 l; Diesel.
Getriebe AS12INT	ZF AS-Tronic; Automatisiertes Schaltgetriebe mit integriertem Retarder, 12 Vorwärts- und 2 Rückwärtsgänge; 2-stufiges Verteilergetriebe mit schaltbarer Geländestufe und zuschaltbarer Längssperre.
Achsen 8 x 6 x 8	8 x 6 x 8; 4 Achsen, davon Achsen 1, 2, 4 angetrieben mit zuschaltbarer Quersperre, alle Achsen gelenkt.
Federung	Hydropneumatische Federung mit Achslastausgleich; Hydraulische Blockierung; Wahlweise manuelle oder automatische Niveaueinstellung.
Lenkung	Zweikreis-Hydro-Servocom-Lenkung mit Notlenkpumpe; Aktive Hinterachslenkung (Achsen 3 und 4) mit 6 verschiedenen Lenkprogrammen.
Bremsen	Pneumatische Zweikreis-Betriebsbremse mit ABS, auf alle Räder wirkend; Scheibenbremsen; Zusätzlich Auspuffklappenbremse und Konstantdrossel; Federspeicher-Feststellbremse.
Räder 38595 170F	385/95R25 170F (14.00R25); Stahlfelgen 9,50-25/1,7" CR.
Kabine Fahrgestell 2550	Typ 2,55 m; Einstellbarer Fahrersitz mit Sitzheizung, Armlehnen und pneumatischer Federung; Lenkrad mit Höhen- und Neigungsverstellung; Fensterheber elektrisch; Getönte Verglasung; Vorbereitung Klimaanlage und Radio; 2 integrierte Rundumleuchten; Ablage.
Heizung motorabhängig 12	Motorabhängige Warmwasserheizung mit 12 kW Heizleistung.
Fahrbeleuchtung	Inklusive Abblendlicht, Fernlicht, Tagfahrlicht.
Tempomat	Automatische Geschwindigkeitskontrolle inklusive Bremsomat-Funktion.
Elektronische Wegfahrsperre	Verhindert ungewollte Inbetriebsetzung des Fahrgestells; Inkl. 2 elektronischen Schlüsseln und 4 Zündschlüsseln.
Sonstige	Aufstiege; Pneumatischer Reifenfüllanschluss.

Kran

Teleskopausleger HA50	11,9 m - 50,0 m; Einzylinder-Teleskopiersystem, wahlweise automatisches oder manuelles Teleskopieren; Aufnahmen für alle optionalen Einrichtungen; 5 Seilrollen im Auslegerkopf für max. 64,5 t Tragfähigkeit.
Gegengewicht EG21	20,2 t, 5-teilig; Automatisches Rüstsystem; Auf max. 25,2 t erweiterbar; 20,2 t können serienmäßig am Gerät mitgeführt werden; 4,5 t am Kran fixiert.
Abstützung	H-4-Punkt-Anordnung; Vertikale und horizontale Bewegung vollhydraulisch; Wahlweise manuelle oder automatische Niveaueinstellung beidseitig am Fahrgestell; 4 Abstützbasen.
Stützteller 028	4 Stützteller A = 0,28 m ² mit Transportstellung am Stützzyliner.
Auslegerverstellung	Wippzylinder mit lastdrucküberkompensiertem Sicherheits-Senk-Brems-Ventil.
Drehantrieb	Drehwerk mit federbelasteter Lamellenbremse.
H1	Hubwerk mit federbelasteter Lamellenbremse; Integrierter Drehmelder.
Motor 129-4	MTU; Leistung 129 kW (175 PS) bei 2200 1/min, Drehmoment 750 Nm bei 1200 1/min, zertifiziert nach EURO MOT 4, TIER 4, CARB; Abgasanlage inkl. Funkenfänger aus Edelstahl.
Kraftstoffbehälter 200	200 l; Diesel.
Antrieb	Leistungegeregelte Hydraulikanlage; Hydraulikölkühler.
Steuerung	Ermöglicht 4 gleichzeitige Arbeitsbewegungen; Elektrische Vorsteuerung über 2 Kreuzsteuerhebel.
Sicherheitseinrichtung	IC-1, mit integriertem Lastmomentbegrenzungssystem gemäß EN13000; Farbdisplay; Anzeige Betriebszustand, Traglasttabellen, Fehlerindikator; Ampelsignal LMB-Auslastung; Krandatenrekorder.
Arbeitsbereichsbegrenzung	Anzeige und Programmierbarkeit der Arbeitsbereichsgrenzen über IC-1.
Kabine Kran 0875	Typ 0,875 m; Stufenlose Neigung 20°; Sitzheizung; Frontscheibe aufstellbar; Ausfahrbares Seiten- und klappbares Frontpodest; Handläufe; Getönte Sicherheitsverglasung; Sonnenschutzrollo; Vorbereitung Klimaanlage und Radio.
Heizung motorabhängig 12	Motorabhängige Warmwasserheizung mit 12 kW Heizleistung.

Diverse

Arbeitsbeleuchtung	1 x Arbeitsvorfeld an Krankabine, 4 x für Abstützung.
Rundumleuchten 2	2 x auf Fahrkabine integriert, 2 x abnehmbar auf Kranheck.
Kontur-Sicherheitsmarkierung	Durchgängige, gelbe Reflektorleisten seitlich am Fahrgestell und am Heck.
Stehleiter	Lose Stehleiter für Montagearbeiten; Inkl. Transportstellung.

Optionen

Fahrgestell

Achsen 8 x 8 x 8	8 x 8 x 8; Alle 4 Achsen gelenkt und permanent angetrieben mit zuschaltbarer Quersperre.
Transporthalterung für Gegengewicht „b“ auf Heck	Gestell zur Ablage des Gegengewichtsteils „b“ à 2,9 t auf dem Heck; Erforderlich beim Transport von 9,0 t Gegengewicht.
Räder 44595 174F	445/95R25 174F (16.00R25); Stahlfelgen 11,00-25/1,7" CR.
Räder 52580 179E	525/80R25 179E (20.50R25); Stahlfelgen 17,00-25/1,7" CR; Inkl. Fahrzeugverbreiterung auf 2,75 m.
Zusatzheizung motorunabhängig Fahrgestell 10	Zusätzliche, motorunabhängige Diesel Standheizung mit 10 kW Heizleistung; Programmierbare Zeitschaltuhr; Umschaltbar zwischen Motorvorwärmung und Kabine Fahrgestell.
Klimaanlage Fahrgestell 7	Klimaanlage für Fahrkabine mit 7 kW Kühlleistung.

Kran

Teleskopausleger HA60	12,0 m - 59,4 m; Einzylinder-Teleskopiersystem, automatisches Teleskopieren; Aufnahmen für alle optionalen Einrichtungen; 5 Seilrollen im Auslegerkopf für max. 64,5 t Tragfähigkeit.
Fernbedienung RK S1V	Vollwertige Steuerung aller Rüst- und Kranbewegungen per Funkfernsteuerung.
H2X	Schwerlasteinrichtung Stufe 1, 2-rollig; De- / montierbar; Für insgesamt 7 Seilrollen am Auslegerkopf; Max. Tragfähigkeit 80,0 t.
Gegengewicht NEG21	2. Hubwerk; Federbelastete Lamellenbremse; Integrierter Drehmelder; Selbstrüstbar; Inkl. Schnellkupplungen und Transporthalterung; Ermöglicht 2-Haken-Betrieb an allen Verlängerungen.
Zusatzgegengewicht EG	Variante für Länder mit speziellen Zulassungsvorschriften; Ermöglicht Selbstabrüstung < 40 t Gesamtgewicht und Achslasten < 12 t; 20,7 t, 6-teilig; Automatisches Rüstsystem, auf max. 25,4 t erweiterbar; Individuelle Technische Klärung erforderlich.
Zusatzgegengewicht NEG	5,0 t, 2-teilig; Für max. 25,2 t, 7-teilig; Nur in Verbindung mit Gegengewicht EG21.
Schnellverbindung HA2	4,7 t, 1-teilig; Für max. 25,4 t, 7-teilig; Nur in Verbindung mit Gegengewicht NEG21.
Stützkraftanzeige	Hydraulische Ziehvorrichtungen für Ausleger- und Wippzylinderbolzen sowie hydraulische und elektrische Schnellkupplungen ermöglichen schnellen Ein- / ausbau; Inkl. Ablage Wippzylinder.
Stützbasiserfassung	Anzeige in LMB Krankabine.
Verfahren aus der Krankabine	Einzelersfassung der Stützträger zum visuellen Abgleich mit der programmierten Stützbasis; Anzeige in LMB-Krankabine (Achtung – es erfolgt keine automatische Koppelung mit dem LMB-System!).
Zusatzheizung motorunabhängig Kran 5	Steuerung des Fahrgestells aus der Krankabine, zum auferüsteten Umsetzen der Maschine, auch unter Last.
Klimaanlage Kran 7	Zusätzliche, motorunabhängige Diesel-Standheizung mit 5 kW Heizleistung; Programmierbare Zeitschaltuhr und Fernaktivierung; Umschaltbar zwischen Motorvorwärmung und Kabine Fahrgestell.
	Klimaanlage in Krankabine mit 7 kW Kühlleistung.

Verlängerungen

HAV19	10 m / 19 m; Doppelklappspitze, manuell 20° / 40° abwinkelbar; 1-rolliger Kopf; Inkl. Transporthalterung; Beinhaltet HAV10; Betrieb an HA oder VA.
HAV27	27 m; Variable Verlängerung mit Klappspitze, manuell 20° / 40° abwinkelbar; 1-rolliger Kopf; Inkl. Transporthalterung; Beinhaltet HAV19.
HAV-HY	Hydraulische, stufenlose Abwinkelung 0°-40°, anstelle der manuellen Abwinkelung; Für HAV10 bzw. HAV19 und HAV27.
MSF2	1,5 m; Montagespitze starr; 2-rollig für max. 26,6 t Tragfähigkeit; Inkl. Transporthalterung am Auslegerkopf.
R1	Seitlich klappbare Kopffrolle; Inkl. Transporthalterung; Für einsträngigen Betrieb mit erhöhter Hakenhöhe.

Diverse

Raffinerie-Paket 2M	Motor-Schnellstoppeinrichtung mit Luftabsperklappe für Fahrgestell und Kran.
Vorbereitung Dolly 4PV	4-Punkt Konsole ermöglicht individuelle Positionierung eines Dolly; Inkl. Freilauf für Drehwerk und Schwimmstellung für Wippzylinder, Schnellkupplungen für Bremsluft und Elektrik; Dolly sowie Dollyadapter sind nicht enthalten.
Unterflasche 100-7-18-D	100-7-18-D (750 kg); Unterflasche mit Doppelhaken; weiss mit roter Warnschraffur.
Unterflasche 80-5-18-D	80-5-18-D (650 kg); Unterflasche mit Doppelhaken; weiss mit roter Warnschraffur.
Unterflasche 80-5-18-E	80-5-18-E (650 kg); Unterflasche mit Einfachhaken; weiss mit roter Warnschraffur.
Unterflasche 50-3-18-D	50-3-18-D (550 kg); Unterflasche mit Doppelhaken; weiss mit roter Warnschraffur.
Unterflasche 50-3-18-E	50-3-18-E (550 kg); Unterflasche mit Einfachhaken; weiss mit roter Warnschraffur.
Unterflasche 20-1-18-E	20-1-18-E (300 kg); Unterflasche mit Einfachhaken; weiss mit roter Warnschraffur.
Lasthaken 8-0V-18-E	8-0V-18-E (170 kg); Einfachhaken mit Vertikalgelenk; rot.

Équipement de base

Châssis

Moteur 340-4	MTU ; puissance 340 kW (462 HP) à 1700 1/min, couple 2200 Nm à 1300 1/min, conforme aux normes EURO MOT 4, TIER 4, CARB ; Système d'échappement en acier inoxydable avec pare étincelles certifié.
Réservoir de carburant 400	400 l Diesel.
Boîte de vitesses AS12INT	ZF AS-Tronic ; Boîte automatique avec ralentisseur intégré ; 12 vitesses AV, 2 AR ; boîte de transfert à deux rapports avec dispositif tout-terrain commutable et blocage du différentiel longitudinal sélectionnable.
Essieux 8 x 6 x 8	8 x 6 x 8 ; 4 essieux dont essieux 1, 2, 4 moteur et équipés du blocage de différentiel commutable, tous les essieux directeurs.
Suspension	Suspension hydropneumatique avec compensation du poids de l'essieu ; blocage hydraulique ; mise à niveau manuelle ou automatique.
Direction	Direction servocom à deux circuits avec pompe de secours ; direction active des essieux arrière (essieux 3 et 4) avec 6 programmes de direction différents.
Freins	Frein de service pneumatique à double circuit avec ABS sur toutes les roues ; freins à disques ; frein additionnel sur échappement et papillon des gaz constant en sus ; freins de stationnement à serrage par ressorts.
Roues 38595 170F	385/95R25 170F (14.00R25) ; jantes en acier 9,50-25/1,7" CR.
Cabine du châssis 2550	Modèle 2,55 m ; Siège réglable avec siège chauffant, accoudoirs et suspension pneumatique ; hauteur et inclinaison de la roue directrice réglables ; vitres électriques ; vitre de teinté ; préparation de climatisation et de radio ; 2 gyrophares intégrés ; compartiments de rangement.
Chauffage, dépendant du moteur 12	Chauffage à eau dépendant du moteur avec puissance de chauffage de 12 kW.
Feux de conduite	Avec position feux de croisement/plein phare, feux diurnes.
Régulateur de vitesse	Contrôle automatique de la vitesse avec fonction Bremsomat.
Dispositif d'immobilisation électronique	Empêche un mouvement inopiné du châssis ; avec 2 clés électroniques et 4 clés de contact.
Divers	Élévateurs ; Valve de gonflage pneumatique.

Grue

Flèche télescopique HA50	11,9 m - 50,0 m ; système de télescopage à vérin unique, télescopage manuel ou automatique ; fixations pour tous les équipements supplémentaires ; 5 poulies dans la tête de flèche pour une capacité de levage max. de 64,5 t.
Contrepoids EG21	20,2 t, 5 éléments ; système d'amarrage automatique ; extensible jusqu'à 25,2 t max. ; la machine peut transporter jusqu'à 20,2 t ; 4,5 t fixées sur la grue.
Calage	Agencement 4 points H ; télescopages verticaux et horizontaux entièrement hydrauliques ; mise à niveau manuelle ou automatique depuis des deux côtés du châssis ; 4 bases de calage.
Plateau de support 028	4 plateaux de support A = 0,28 m ² avec position de transport sur le vérin d'appui.
Réglage de la flèche	Vérin de relevage avec soupape de freinage.
Entraînement rotatif	Dispositif d'orientation avec frein multidisque à ressort.
H1	Mécanisme de levage avec frein multidisque à ressort ; indicateur de rotation intégré.
Moteur 129-4	MTU ; puissance 129 kW (175 HP) à 2200 1/min, couple 750 Nm à 1200 1/min, conforme aux normes EURO MOT 4, TIER 4, CARB ; Circuit d'échappement incl. pare-étincelles en acier inox.
Réservoir de carburant 200	200 l Diesel.
Entraînement	Système hydraulique à servocommande ; refroidisseur d'huile hydraulique.
Commande	Permet 4 mouvements de travail simultanés ; commande pilote électrique via deux leviers de commande en croix.
Dispositif de sécurité	IC-1, avec contrôleur d'état de charge intégré selon EN13000 ; affichage couleur ; affichage des conditions de travail, tableaux de charge, indicateur d'erreur ; signal lumineux charge LMB ; enregistreur des données de la machine.
Contrôleur de portée	Affichage et programmabilité des limites de la plage de travail sur dispositif IC-1.
Cabine de la grue 0875	Modèle 0,875 m ; inclinaison en continu jusqu'à 20° ; siège chauffant ; pare-brise réglable ; quai latéral extensible et quai avant repliable ; mains courantes ; vitre de sécurité teinté ; visière rabattable ; préparation de climatisation et de radio.
Chauffage, dépendant du moteur 12	Chauffage à eau dépendant du moteur avec puissance de chauffage de 12 kW.

Divers

Éclairage de la zone de travail	1 x avant champ de travail de la cabine de grue, 4 x pour le calage.
Gyrophares 2	2 x intégrés sur la cabine de conduite, 2 x amovibles sur l'arrière de la grue.
Signalisation sur le contour	Bandes réfléchissantes continues sur le côté du châssis et à l'arrière.
Marchepied	Marchepieds mobiles pour travaux de montage ; support de transport inclus.

Options

Châssis

Essieux 8 x 8 x 8	8 x 8 x 8 ; 4 essieux directeurs et moteurs permanents avec blocage de différentiel transversal.
Position de transport des contrepoids « b » à l'arrière	Châssis de stockage de la pièce de contrepoids « b » de 2,9 t à l'arrière ; nécessaire lors du transport de contrepoids de 9,0 t.
Roues 44595 174F	445/95R25 174F (16.00R25) ; jantes en acier 11,00-25/1,7" CR.
Roues 52580 179E	525/80R25 179E (20.50R25) ; jantes en acier 17,00-25/1,7" CR ; extension du véhicule à 2,75 m incl.
Chauffage supplémentaire, indépendant du moteur du châssis 10	Chauffage d'appoint supplémentaire, indépendant du moteur Diesel avec puissance de chauffage de 10 kW ; avec minuterie programmable. Sélection entre préchauffage moteur et cabine de conduite.
Climatisation du châssis 7	Climatisation pour la cabine avec puissance de refroidissement de 7 kW.

Grue

Flèche télescopique HA60	12,0 m - 59,4 m ; système de télescopage à vérin unique, télescopage automatique ; fixations pour tous les équipements supplémentaires ; 5 poulies dans la tête de flèche pour une capacité de levage max. de 64,5 t.
Commande à distance RK S1V	Manœuvre intégrale de l'implantation et des opérations de la grue par commande à distance sans fil. Equipement pour levage lourd niveau 1, 2 poulies ; montable/démontable ; pour 7 poulies au total sur la tête de flèche ; capacité de levage max. 80,0 t.
H2X	2ème dispositif de levage ; freins multidisques à ressorts ; indicateur de rotation intégré ; auto-amarrage ; connexions rapides et position de transport incl. ; permet le fonctionnement à 2 crochets sur toutes les extensions.
Contrepoids NEG21	Variante pour les pays imposant des autorisation spéciales ; permet un auto-désarmement < 40 t contrepoids et charges sur essieux < 12 t ; 20,7 t, 6 éléments ; système d'amarrage automatique, extensible jusqu'à 26,1 t ; explications techniques personnalisées nécessaires.
Contrepoids supplémentaire EG	5,0 t ; 2 éléments ; pour 25,2 t max., 7 éléments ; uniquement en combinaison avec le contrepoids EG21.
Contrepoids supplémentaire NEG	4,7 t ; 1 élément ; pour 25,4 t max., 7 éléments ; uniquement en combinaison avec le contrepoids NEG21.
Connexion rapide HA2	Extracteurs d'axes hydrauliques et connexions hydrauliques et électriques rapides pour montage/démontage rapide ; Support de transport incl. pour vérin de relevage.
Affichage des réactions aux appuis	Affichage dans la cabine LMB.
Contrôle de la base de calage	Surveillance de chaque poutre de calage pour une comparaison visuelle avec la base de calage programmée ; affichage dans la cabine du grutier LMB (Attention ! Absence de connexion automatique avec le système LMB !).
Déplacement depuis la cabine de la grue	Commande du châssis depuis la cabine, permet le déplacement de la machine même en charge.
Chauffage d'appoint indépendant du moteur 5	Chauffage indépendant du moteur Diesel avec puissance de chauffage de 5 kW ; avec minuterie programmable et enclenchement à distance ; permutable entre bloc moteur et cabine de conduite.
Climatisation de la grue 7	Climatisation dans la cabine du grutier avec puissance de refroidissement de 7 kW.

Extensions

HAV19	10 m / 19 m ; Double fléchette pliante, inclinable manuellement à 20° / 40° ; tête à 1 poulie ; position de transport incl. ; HAV 10 inclus ; fonctionnement sur HA ou VA.
HAV27	27 m ; Extension variable avec fléchette pliante, inclinable manuellement à 20° / 40° ; tête à 1 poulie ; position de transport incl. ; HAV 19 inclus.
HAV-HY	Décalage hydraulique en continu 0°-40°, en remplacement du décalage manuel ; pour HAV10, respectivement HAV19 et HAV27.
MSF2	1,5 m ; fléchette de montage fixe, 2 poulies pour capacité max. de 26,6 t. Avec support de transport en tête de flèche.
R1	Poulie auxiliaire pliable latéralement ; position de transport incl. ; pour levages à brin simple avec hauteur sous crochet supérieure.

Divers

Kit raffinerie 2M	Dispositif de mise hors service rapide pour le moteur muni d'un clapet anti-retour, pour châssis et grue.
Préparation Dolly 4PV	Console 4 points, pour un positionnement individuel d'un dolly ; roue libre pour dispositif d'orientation et position flottante pour vérins de relevage incl., ainsi que connexions rapides pour contre-air et système électrique ; Le dolly et l'adaptateur pour dolly ne sont pas inclus.
Moufle 100-7-18-D	100-7-18-D (750 kg) ; moufle avec crochet double ; blanc avec bandes de signalisation rouges.
Moufle 80-5-18-D	80-5-18-D (650 kg) ; moufle avec crochet double ; blanc avec bandes de signalisation rouges.
Moufle 80-5-18-E	80-5-18-E (650 kg) ; moufle avec crochet simple ; blanc avec bandes de signalisation rouges.
Moufle 50-3-18-D	50-3-18-D (550 kg) ; moufle avec crochet double ; blanc avec bandes de signalisation rouges.
Moufle 50-3-18-E	50-3-18-E (550 kg) ; moufle avec crochet simple ; blanc avec bandes de signalisation rouges.
Moufle 20-1-18-E	20-1-18-E (300 kg) ; moufle avec crochet simple ; blanc avec bandes de signalisation rouges.
Crochet 8-0V-18-E	8-0V-18-E (170 kg) ; crochet simple avec pivot vertical ; rouge.

Allestimento di base

Carro

Motore 340-4	MTU; potenza 340 kW (462 HP) a 1700 1/min, coppia 2200 Nm a 1300 1/min, esecuzione a norma EURO MOT 4, TIER 4, CARB; impianto di scarico in acciaio inossidabile con parascintille certificato.
Serbatoio carburante 400	400 l; carburante diesel.
Cambio AS12INT	ZF AS-Tronic; Cambio automatico con retarder integrato, 12 marce avanti e 2 retromarce; distributore di coppia a 2 rapporti, con rapporto fuori strada e blocco differenziale longitudinale inseribili.
Assi 8 x 6 x 8	8 x 6 x 8; 4 assi, di cui gli assi 1, 2, 4 traenti con blocco differenziale trasversale inseribile, tutti gli assi sterzanti.
Sospensioni	Sospensioni idropneumatiche con compensazione del carico assiale; blocco idraulico; disponibili nella versione con regolazione del livello manuale o automatica.
Sterzo	Servosterzo idraulico a doppio circuito con pompa di soccorso; Sterzata attiva degli assi posteriori (assi 3 e 4), con 6 diversi programmi di sterzata.
Freni	Freno di servizio pneumatico a doppio circuito con ABS, installato su tutte le ruote; freni a disco; freno motore aggiuntivo con farfalla non regolabile; freno di stazionamento a molla.
Ruote 38595 170F	385/95R25 170F (14.00R25); cerchi in acciaio 9,50-25/1,7" CR.
Cabina del carro 2550	Tipo 2,55 m; sedile di guida regolabile, con riscaldamento del sedile, braccioli e sospensioni pneumatiche; volante regolabile in altezza e inclinazione; alzacristalli elettrici; vetri oscurati; predisposizione per climatizzatore e radio; 2 girofari integrati; vani di stoccaggio.
Riscaldamento, tramite motore 12	Sistema di riscaldamento acqua calda tramite motore, con potenzialità di riscaldamento 12 kW.
Fari di guida	Dotazione comprendente anabbaglianti, abbaglianti, luci per la marcia diurna.
Cruise control	Controllo automatico della velocità, con funzione Bremsomat (controllo automatico dei freni).
Immobilizzatore elettronico	Impedisce l'avviamento involontario del carro; completo di 2 chiavi elettroniche e 4 chiavi di accensione.
Altro	Moduli di salita; raccordo di gonfiaggio pneumatici.

Gru

Braccio telescopico HA50	11,9 m - 50,0 m; Sistema di sfilo a un cilindro, configurabile con sfilo manuale o automatico; Predisposizioni per il collegamento di tutti gli accessori opzionali; 5 pulegge integrate nella punta del braccio per una portata max. di 64,5 t.
Contrappeso EG21	20,2 t, divisibile in 5 blocchi; con sistema di autozavorramento; incrementabile fino a 25,2 t; 20,2 t possono essere installate a bordo macchina di serie; 4,5 t possono essere fissate alla gru.
Stabilizzatori	Sistema a 4 stabilizzatori; estensione orizzontale e verticale completamente idraulica; disponibili nella versione con regolazione del livello automatica o manuale dal lato del carro; 4 basi di appoggio.
Piatti stabilizzatori 028	4 piatti stabilizzatori A = 0,28 m ² , con possibilità di sistemazione in corrispondenza dei cilindri di stabilizzazione in fase di trasporto.
Sfilo del braccio	Cilindro differenziale, dotato di valvola di comando del freno di discesa con controllo della pressione a carico.
Azionamento rotazione	Meccanismo di rotazione con freno lamellare a molla.
H1	Argano con freno lamellare a molla; con sincronizzatore integrato.
Motore 129-4	MTU; potenza 129 kW (175 HP) a 2200 1/min, coppia 750 Nm a 1200 1/min, esecuzione a norma EURO MOT 4, TIER 4, CARB; impianto di scarico in acciaio inossidabile, con parascintille.
Serbatoio carburante 200	200 l; carburante diesel.
Azionamento	Impianto idraulico con controllo della potenza; radiatore olio idraulico.
Sistema di controllo	Consente 4 movimenti operativi in contemporanea; pilotaggio elettrico mediante 2 leve di comando a joystick.
Dispositivi di sicurezza	IC-1, con indicatore di carico integrato conforme a EN13000; display a colori; visualizzazione delle condizioni operative correnti, diagrammi di carico, indicatore di errore; segnalazione in stile semaforo del carico massimo; registratore dati gru.
Limitazione dell'area di lavoro	Funzioni di visualizzazione e programmazione dei limiti dell'area di lavoro con IC-1.
Cabina della gru 0875	Tipo 0,875 m; inclinazione a regolazione infinitesimale 20°; riscaldamento del sedile; parabrezza regolabile; pedana laterale allungabile, pedana frontale ribaltabile; corrimano; vetri di sicurezza oscurati; tendina parasole; predisposizione per climatizzatore e radio.
Riscaldamento, tramite motore 12	Sistema di riscaldamento acqua calda tramite motore, con potenzialità di riscaldamento 12 kW.

Varie

Illuminazione di lavoro	1 per zona di lavoro antistante la cabina della gru, 4 per stabilizzatori.
Girofari 2	2 integrati sulla cabina carro, 2 estraibili sul retro della gru.
Bande di sicurezza per segnalazione sagoma veicolo	Nastri catarifrangenti continui sul carro e sul retro.
Scala a libretto	Scala a libretto separata, adatta per vari lavori di montaggio; con vano di trasporto.

Opzioni

Carro

Assi 8 x 8 x 8	8 x 8 x 8; tutti e 4 gli assi sterzanti e traenti (trazione permanente) con differenziale trasversale inseribile.
Posizione di trasporto per il contrappeso „b“ sul retro	Vano per riporre il contrappeso „b“ da 2,9 t sul retro; per il trasporto è necessario un contrappeso di 9,0 t.
Ruote 44595 174F	445/95R25 174F (16.00R25); cerchioni in acciaio 11,00-25/1,7“ CR.
Ruote 52580 179E	525/80R25 179E (20.50R25); cerchioni in acciaio 17,00-25/1,7“ CR; incl. estensione in larghezza fino a 2,75 m.
Riscaldamento supplementare, indipendente dal motore del carro 10	Riscaldamento autonomo ausiliario, indipendente dal motore, con potenzialità di riscaldamento 10 kW; timer programmabile; possibilità di selezione tra preriscaldamento motore e cabina carro.
Climatizzatore del carro 7	Climatizzatore per cabina di guida con potenzialità di raffreddamento di 7 kW.

Gru

Braccio telescopico HA60	12,0 m - 59,4 m; sistema di sfilo a un cilindro, configurabile con sfilo automatico; predisposizioni per il collegamento di tutti gli accessori opzionali; 5 pulegge integrate nella punta del braccio per una portata max. di 64,5 t.
Radiocomando RK S1V	Controllo completo di attrezzamento e movimenti gru mediante radiocomando wireless. Equipaggiamento pesante stadio 1, a 2 pulegge; montabile/smontabile; per un totale di 7 pulegge sulla punta del braccio; portata max. 80,0 t.
H2X	2. argano; freno lamellare a molla; sincronizzatore integrato; sistema di allestimento automatico; completo di giunti rapidi e posizione di trasporto; consente l'uso di 2 ganci su tutte le prolunghe.
Contrappeso NEG21	Variante per terreni soggetti a requisiti normativi speciali; consente l'autozavorramento < 40 t e carichi assiali < 12 t; 20,7 t, divisibile in 6 blocchi; con sistema di autozavorramento, estendibile fino a max 25,4 t; è necessaria una verifica tecnica.
Contrappeso supplementare EG	5,0 t, divisibile in 2 blocchi; adatto per max. 25,2 t, 7 blocchi; Solo in combinazione con il contrappeso EG21.
Contrappeso supplementare NEG	4,7 t, monoblocco; adatto per max. 25,4 t, 7 blocchi; Solo in combinazione con il contrappeso NEG21.
Accoppiamento rapido HA2	Estrattori idraulici per viti e accoppiamenti rapidi idraulici ed elettrici, consentono un facile montaggio e smontaggio; completo di vano di trasporto per cilindro differenziale.
Indicatore di carico degli stabilizzatori	Indicatori limitatore di carico nella cabina torretta.
Monitoraggio base di appoggio	Sistema di sorveglianza dei cilindri di stabilizzazione per confronto visivo con la base di appoggio programmata; programmata; visualizzazione inclusa nel limitatore di carico della cabina torretta (Attenzione! Tale visualizzazione non è collegata al limitatore di carico!).
Spostamento dalla cabina torretta	Comando del carro dalla cabina torretta, per lo spostamento della gru allestita / sotto carico.
Riscaldamento ausiliario gru indipendente dal motore 5	Impianto di riscaldamento diesel autonomo, indipendente dal motore, con potenzialità di riscaldamento di 5 kW; con timer e sistema di accensione remoto; commutazione su preriscaldamento motore e cabina sul carro.
Climatizzatore della gru 7	Climatizzatore in cabina torretta con potenzialità di raffreddamento di 7 kW.

Prolunghe

HAV19	10 m / 19 m; falcone doppio, manualmente inclinabile 20° / 40°; cabezal de 1 polea; completo di posizione di trasporto; comprende HAV10; opera con HA o VA.
HAV27	27 m; Prolunga regolabile con falcone ripiegabile, manualmente inclinabile 20° / 40°; cabezal de 1 polea; completo di posizione di trasporto; comprende HAV19.
HAV-HY	Inclinazione idraulica a regolazione infinitesimale 0°-40°, anziché inclinazione manuale; Per HAV10 o HAV19 e HAV27.
MSF2	1,5 m; runner fisso, 2 pulegge, portata max. 26,6 t; con vano di trasporto nella testa braccio.
R1	Punta a una puleggia ripiegabile lateralmente; completo di posizione di trasporto; configurabile con un rinvio con una maggiore altezza sottogancio.

Varie

Pacchetto raffineria 2M	Dispositivo di arresto immediato del motore, con valvola di intercettazione aria, per carro e gru.
Predisposizione carrello 4PV	La staffa di supporto a 4 punti consente il posizionamento singolo di un carrello; completo di meccanismo a ruota libera per la rotazione e posizione flottante del cilindro differenziale, nonché di gi aria freni e collegamenti elettrici; carrello e adattatore per carrello non sono inclusi.
Bozzello 100-7-18-D	100-7-18-D (750 kg); bozzello con gancio doppio; bianco con strisce segnaletiche rosse.
Bozzello 80-5-18-D	80-5-18-D (650 kg); bozzello con gancio doppio; bianco con strisce segnaletiche rosse.
Bozzello 80-5-18-E	80-5-18-E (650 kg); bozzello con gancio singolo; bianco con strisce segnaletiche rosse.
Bozzello 50-3-18-D	50-3-18-D (550 kg); bozzello con gancio doppio; bianco con strisce segnaletiche rosse.
Bozzello 50-3-18-E	50-3-18-E (550 kg); bozzello con gancio singolo; bianco con strisce segnaletiche rosse.
Bozzello 20-1-18-E	20-1-18-E (300 kg); bozzello con gancio singolo; bianco con strisce segnaletiche rosse.
Gancio di sollevamento 8-0V-18-E	8-0V-18-E (170 kg); gancio singolo con snodo verticale; rosso.

Equipamiento básico

Chasis

Motor 340-4	MTU; Potencia 340 kW (462 CV) a 1700 rpm, par 2200 Nm a 1300 rpm, certificado conforme a EURO MOT 4, TIER 4, CARB; Sistema de escape de acero inoxidable con parachispas certificado.
Depósito de combustible 400	400 l; Combustible: gasóleo.
Transmisión AS12INT	ZF AS-Tronic; Caja de cambios automática con retardador hidráulico integrado, 12 marchas hacia delante y 2 marchas atrás; Caja de transferencia de 2 etapas con etapa todoterreno accionable y bloqueo longitudinal conmutable.
Ejes 8 x 6 x 8	8 x 6 x 8; 4 ejes, teniendo ejes 1, 2, 4 tracción con bloqueo transversal conmutable, todos los ejes con dirección.
Suspensión	Suspensión hidroneumática con compensación de presión sobre ejes; Mecanismo hidráulico de bloqueo; Puede seleccionarse regulación de nivel manual o automática.
Dirección	Dirección hidráulica servocom de dos circuitos, con bomba auxiliar de emergencia; Dirección activa de ejes traseros (ejes 3 y 4) con 6 programas de conducción distintos.
Frenos	Frenos de servicio neumáticos de dos circuitos, con ABS instalado en todas las ruedas; Frenos de disco; Freno por gases con chapaleta de escape y estrangulador constante; Freno de inmovilización con fuerza acumulada por muelles.
Ruedas 38595 170F	385/95R25 170F (14.00R25); Llantas de acero 9,50-25/1,7" CR.
Cabina del conductor 2550	Tipo 2,55 m; Asiento del conductor ajustable con asientos calefactables, reposabrazos y suspensión neumática; Volante con regulación de altura e inclinación; Elevalunas eléctrico; Acristalamiento de tintado; Preinstalación de climatización y radio; Dos faros omnidireccionales integrados; compartimentos de almacenaje.
Calefacción dependiente 12	Calefacción hidráulica dependiente del motor de 12 kW de potencia.
Luces de conducción	Con luces de cruce, luces largas y luces de circulación diurna.
Control de crucero	Control automático de la velocidad con función Bremsomat.
Inmovilizador electrónico	Evita el movimiento no deseado del chasis; Incl. 2 llaves eléctricas y 4 llaves de encendido.
Diversos	Escalas; Enchufe neumático para inflar neumáticos.

Grúa

Flecha telescópica HA50	11,9 m - 50,0 m; Sistema telescópico monocilíndrico, pudiendo seleccionarse telescopaje automático o manual; Anclajes para todos los equipamientos y extensiones; 5 poleas integradas en cabezal de flecha para capacidad máx. de carga 64,5 t.
Contrapeso EG21	20,2 t, 5 bloques; Automontaje automático; Ampliable a máx. 25,2 t; 20,2 t transportables de serie en la máquina; 4,5 t fijadas en la grúa.
Estabilización	Diseño 4 puntos en H; Movimiento vertical y horizontal por sistema completamente hidráulico; Puede seleccionarse regulación de nivel manual o automática a ambos lados del chasis; 4 bases estabilizadoras.
Bandeja de soporte 028	4 bandejas de soporte A = 0,28 m ² con posición de transporte en el cilindro de soporte.
Basculación de flecha	Cilindro de abatimiento con válvula automática de seguridad para frenado de caída.
Tracción de giro	Mecanismo giratorio con freno multidisco por muelles.
H1	Cabrestante con freno multidisco por muelles; Sincrotransmisor integrado.
Motor 129-4	MTU; Potencia 129 kW (175 CV) a 2200 rpm, par 750 Nm a 1200 rpm, certificado conforme a EURO MOT 4, TIER 4, CARB; Sistema de escape (incl. parachispas) de acero inoxidable.
Depósito de combustible 200	200 l; Combustible: gasóleo.
Tracción	Equipo hidráulico con control de potencia; Refrigerador de aceite hidráulico.
Sistema de control	Permite cuatro movimientos simultáneos; Controles piloto eléctricos a través de 2 joysticks en cruz.
Dispositivos de seguridad	IC-1, con indicador integrado de momento de carga, EN13000; Pantalla a color; Visualización de estado operativo actual, tablas de carga, indicador de fallos; Luces que indican la carga del indicador de momento de carga; Grabador de datos de grúa.
Delimitación de área de trabajo	Visualización y programación de los límites del área de trabajo por IC-1.
Cabina del operador 0875	Tipo 0,875 m; Inclinación 20° en progresión continua; Asientos calefactables; Luna frontal alzable; Repisa lateral extensible, estrado frontal abatible; Pasamanos. Acristalamiento de seguridad tintado; Persiana-parasol; Preinstalación de climatización y radio.
Calefacción dependiente 12	Calefacción hidráulica dependiente del motor de 12 kW de potencia.

Otros

Alumbrado de trabajo	1 regulable en cabina de grúa para campo inmediato de trabajo, 4 para estabilizadores.
Faros omnidireccionales 2	2 integrados en cabina de chasis, 2 desconectables en parte trasera de la grúa.
Marcas de seguridad en contorno	Bandas reflectoras continuas en el lado del bastidor y en la parte trasera.
Escalera plegable	Escalera plegable suelta para tareas de montaje varias; Incl. almacenamiento de transporte.

Opciones

Chasis

Ejes 8 x 8 x 8	8 x 8 x 8; Cuatro ejes directores y motores permanentes con bloqueo de diferencial transversal.
Puesto de transporte para contrapeso „b“ en trasera de vehículo	Estructura para depositar en trasera el contrapeso „b“ de 2,9 t; Requisito para transportar a bordo 9,0 t de contrapeso.
Ruedas 44595 174F	445/95R25 174F (16.00R25); Llantas de acero 11,00-25/1,7" CR.
Ruedas 52580 179E	525/80R25 179E (20.50R25); Llantas de acero 17,00-25/1,7" CR; Incl. ensanchamiento de vehículo a 2,75 m.
Calefacción adicional, independiente del motor del chasis 10	Calefacción diésel auxiliar independiente del motor con 10 kW de potencia; Temporizador; Posibilidad de precalentamiento de motor y cabina.
Climatización del chasis 7	Climatización en cabina de 7 kW de potencia.

Grúa

Flecha telescópica HA60	12,0 m - 59,4 m; Sistema telescópico monocilíndrico, pudiendo seleccionarse telescopaje automático; Anclajes para todos los equipamientos y extensiones; 5 poleas integradas en cabezal de flecha para capacidad máx. de carga 64,5 t.
Control remoto RK S1V	Control total de los movimientos de preparación y de la de grúa por radiocontrol remoto. Dispositivo para cargas pesadas 1, con 2 poleas; (Des-)montable; Para total de 7 poleas en cabezal de flecha y capacidad de carga máx. 80,0 t.
H2X	2 cabrestante; Freno multidisco por muelles; Sincrotransmisor integrado; Automontaje; Incl. enganches rápidos y puesto de transporte; Posibilita operar con 2 ganchos en todas las extensiones.
Contrapeso NEG21	Versión para países con normativas especiales de autorización; Posibilita autodesinstalación para < 40 t peso total y ejes de carga < 12 t; 20,7 t, en 6 bloques; Automontaje automático, ampliable a 25,4 t máx.; Requiere comprobación técnica individual.
Contrapeso adicional EG	5,0 t, en 2 bloques; Para máx. 25,2 t, en 7 bloques; Sólo en conexión con contrapeso EG21.
Contrapeso adicional NEG	4,7 t, en 1 bloque; Para máx. 25,4 t, en 7 bloques; Sólo en conexión con contrapeso NEG21.
Ensamble rápido HA2	Extractores hidráulicos de tornillos y acoples rápidos hidráulicos y eléctricos para agilizar el (des)montaje; Incl. almacenamiento de transporte para cilindro de elevación.
Indicador de carga sobre estabilizadores	Indicación en cabina LMB.
Monitorización de la base de estabilización	Vigilancia de cada viga estabilizadora para comparación visual con la base de estabilización programada. Mostrado en el indicador de momento de carga de la cabina de grúa (¡Atención! ¡No existe una conexión directa con el sistema indicador de momento de carga!).
Desplazamiento desde cabina de grúa	Control del vehículo desde la cabina de grúa, posibilita mover la máquina preparada, incluso con carga.
Calefacción auxiliar, independiente del motor grúa 5	Sistema de calefacción a gasóleo auxiliar, independiente del motor, con una potencia de calefacción de 5 kW; Con temporizador y encendido remoto; Interconectable entre precalentamiento de motor y cabina de chasis.
Climatización de grúa 7	Climatización en cabina de 7 kW de potencia.

Extensiones

HAV19	10 m / 19 m; Plumín de doble articulación, angulable manualmente en 20° / 40°; Cabezal de 1 polea; Incl. puesto de transporte; Contiene HAV10; Opera con HA ó VA.
HAV27	27 m; Extensión variable con plumín articulado, angulable manualmente en 20° / 40°; Cabezal de 1 polea; Incl. puesto de transporte; Contiene HAV19.
HAV-HY	Angulamiento hidráulico continuo 0°-40°, en vez de angulamiento manual; Para HAV10, respectivamente HAV19 y HAV27.
MSF2	1,5 m; Plumín de montaje fijo, 2 poleas para capacidad de carga máx. 26,6 t; Incl. almacenamiento de transporte en el extremo de la pluma.
R1	Polea en cabezal de pluma, plegable lateralmente; Incluye puesto de transporte; Para operaciones con un solo cable con altura de gancho incrementada.

Otros

Equipo refinera 2M	Dispositivo de parada rápida del motor, con mariposa para corte de aire, para chasis y grúa.
Preinstalación dolly 4PV	Consola de cuatro puntos que permite el posicionamiento individual de un dolly; Incl. piñón libre para pivote y cilindro de abatimiento, así como enganches rápidos para aire de frenado y dispositivos eléctricos; Dolly y adaptador de dolly no incluidos.
Gancho 100-7-18-D	100-7-18-D (750 kg); Bloque de gancho con gancho doble; blanco con franjas rojas de advertencia.
Gancho 80-5-18-D	80-5-18-D (650 kg); Bloque de gancho con gancho doble; blanco con franjas rojas de advertencia.
Gancho 80-5-18-E	80-5-18-E (650 kg); Bloque de gancho con gancho sencillo; blanco con franjas rojas de advertencia.
Gancho 50-3-18-D	50-3-18-D (550 kg); Bloque de gancho con gancho doble; blanco con franjas rojas de advertencia.
Gancho 50-3-18-E	50-3-18-E (550 kg); Bloque de gancho con gancho sencillo; blanco con franjas rojas de advertencia.
Gancho 20-1-18-E	20-1-18-E (300 kg); Bloque de gancho con gancho sencillo; blanco con franjas rojas de advertencia.
Enganche de suspensión 8-0V-18-E	8-0V-18-E (170 kg); Gancho simple con articulación vertical; rojo.

Equipamento básico

Chassi

Motor 340-4	MTU; Potência 340 kW (462 HP) a 1700 rpm, torque 2200 Nm a 1300 rpm, certificações de acordo com a EURO MOT 4, TIER 4, CARB; Sistema de descarga de aço inoxidável com placa antifagulhas certificada.
Tanque de combustível 400	400 l; Comb: Diesel.
Transmissão AS12INT	ZF AS-Tronic; Câmbio automático com retardador hidráulico integrado, 12 marchas à frente e 2 à ré; Caixa de transferência de 2 estágios com marcha fora-da-estrada e bloqueio longitudinal selecionáveis
Eixos 8 x 6 x 8	8 x 6 x 8; 4 eixos; os eixos movidos 1, 2 e 4 são equipados com bloqueio transversal selecionável, todos os eixos esterçáveis.
Suspensão	Suspensão hidropneumática com compensação de carga por eixo; Bloqueio hidráulico; Opção de nivelamento manual ou automático.
Direção	Direção hidráulica de duplo circuito servocom com bomba de emergência; Direção ativa nos eixos traseiros (eixos 3 e 4) com 6 programas de manobra diferentes.
Freios	Freio de serviço com duplo circuito pneumático e sistema antibloqueio atuando em todas as rodas; Freios a disco; Freio motor adicional por válvula borboleta na descarga; Freio de estacionamento por ação de mola.
Rodas 38595 170F	385/95R25 170F (14.00R25); Aros de aço 9,50-25/1,7" CR.
Cabine chassi 2550	Tipo 2,55 m; Assento do motorista ajustável com aquecimento, descanso para braços e suspensão pneumática; Altura e inclinação do volante ajustáveis; Janelas com vidros elétricos; Vidros fumê; Instalação para ar condicionado e rádio; 2 faróis rotativos integrados; Área de armazenamento.
Aquecimento pelo motor 12	Aquecedor de água com 12 kW de potência obtida do motor.
Faróis dianteiros	Com faixa baixo, faixa alto, luzes de percurso diurno.
Piloto automático	Piloto automático com controle automático do freio.
Sistema imobilizador eletrônico	Impede a movimentação sem controle do veículo; Incl. 2 chaves eletrônicas e 4 chaves de ignição.
Diversos	Acesso; Adaptador para calibragem dos pneus.

Grua

Lança telescópica HA50	11,9 m - 50,0 m; Sistema telescópico de cilindro único, opção de extensão manual ou automática; Acessórios para todos os equipamentos e extensões; 5 roldanas integradas na cabeça da lança, capacidade máx. de 64,5 t.
Contrapeso EG21	20,2 t, 5 peças; Sistema de montagem automático; Expansível até máx. 25,2 t; Carga máxima a bordo de 20,2 t no modelo de série; 4,5 fixas na traseira da grua.
Estabilizadores	Projeto em H com 4 pontos; Agitação vertical e horizontal totalmente hidráulica; Opção de nivelamento manual ou automático nos dois lados do veículo; 4 bases de sustentação.
Patolas 028	4 patolas A = 0,28 m ² com posição de transporte no cilindro vertical.
Elevação da lança	Pistão elevatório único com válvula automática de frenagem da descida.
Acionamento da rotação H1	Engrenagem de giro única com freio multidisco por ação de mola.
Motor 129-4	Guincho com freio multidisco por ação de mola; Posicionador.
Tanque de combustível 200	MTU; Potência 129 kW (175 HP) a 2200 rpm, torque 750 Nm a 1200 rpm, certificações de acordo com a EURO MOT 4, TIER 4, CARB; Sistema de escapamento compl. em aço inoxidável, incl. inibidor de faíscas.
Tração	200 l; Comb: Diesel.
Sistema de controle	Sistema hidráulico com controle de potência; Radiador de óleo hidráulico.
Equipamentos de segurança	Admitindo 4 movimentos de trabalho simultâneos; Controles elétricos da pilotagem por 2 joysticks com botões direcionais.
Limitador do raio de trabalho	IC-1, com indicador integrado do momento de carga conf. EN13000; Monitor colorido; Apresenta as condições de operação do momento, tabelas de carga, indicador de falhas; Lâmpadas indicadoras da carga no LMI; Gravador de dados da grua.
Cabine grua 0875	Apresentação e condição de programar os limites da faixa de trabalho pelo IC-1.
Aquecimento pelo motor 12	Tipo 0,875 m; Inclinação variável 20°; Aquecedor do assento; Janela dianteira basculante; Pedestal lateral prolongável e dianteiro dobrável; Corrimãos; Vidro de segurança fumê; Quebra-sol e cortinas; Instalação para ar condicionado e rádio.
	Aquecedor de água com 12 kW de potência obtida do motor.

Diversos

Iluminação	1 x regulável na cabine para campo imediato de trabalho, 4 x para estabilizadores.
Faróis rotativos 2	2 integrados na cabine do veículo, 2 desconectáveis na traseira da grua.
Marcação de segurança no entorno	Faixas refletoras contínuas nas laterais e traseira do chassi.
Escada de abrir	Escada solta para trabalhos diversos de montagem; Incl. armazenagem de transporte.

Opcionais

Chassi

Eixos 8 x 8 x 8	8 x 8 x 8; Todos os eixos esterçáveis, com tração permanente e equipados com bloqueio transversal selecionável.
Armazenagem para transporte do contrapeso 'b' na traseira do veículo	Quadro de apoio para guardar o contrapeso 'b' de 2,9 t na traseira do veículo; Necessário para embarcar contrapesos de 9,0 t.
Rodas 44595 174F	445/95R25 174F (16.00R25); Aros de aço 11,00-25/1,7" CR.
Rodas 52580 179E	525/80R25 179E (20.50R25); Aros de aço 17,00-25/1,7" CR; Incl. alargador do veículo até 2,75 m.
Aquecimento auxiliar independente do veículo 10	Sistema auxiliar de aquecimento do diesel independente do motor com 10 kW de potência térmica; Com temporizador; Alternável entre bloco do motor e cabine do veículo.
Ar condicionado do veículo 7	Ar condicionado na cabine do veículo com 7 kW de potência de refrigeração.

Grua

Lança telescópica HA60	12,0 m - 59,4 m; Sistema telescópico de cilindro único, extensão automática; Acessórios para todos os equipamentos e extensões; 5 roldanas integradas na cabeça da lança, capacidade máx. de 64,5 t.
Controle remoto RK S1V	Controle completo da preparação e do funcionamento da grua por controle remoto sem fio. Acessório para içamento pesado, 1 estágio, 2 roldanas; Des-/conectável; Para total de 7 roldanas na cabeça da lança; Capacidade máx. de 80,0 t.
H2X	2° guincho; Freio multidisco por ação de mola; Posicionador; Auto-elevável; Incl. engates rápidos e armazenagem de transporte; Habilita operação de 2 ganchos com todas as extensões.
Contrapeso NEG21	Versão para países com regulamentos rodoviários especiais; Permite autodesmontagem < 40 t de peso total e cargas por eixo < 12 t; Total 20,7 t com 6 peças; Sistema de montagem automático, expansível até máx. 25,4 t; Necessária verificação técnica individual.
Contrapeso adicional EG	5,0 t, 2 peças; Para máx. 25,2 t em 7 peças; Só junto com o contrapeso EG21.
Contrapeso adicional NEG	4,7 t, 1 peça; Para máx. 25,4 t em 7 peças; Só junto com o contrapeso NEG21.
Conexão rápida HA2	Extratores de parafusos hidráulicos e engates rápidos hidráulicos e elétricos para rápida montagem e desmontagem. Incl. nicho de transporte do pistão elevatório.
Indicador de carga nos estabilizadores	Mostrado em cabine da grua LMI.
Monitoração da base sobre estabilizadores	Vigilância de cada viga do estabilizador para comparação visual com a base de apoio programada; Mostradas no LMI da cabine da grua (Atenção: não há ligação automática com o sistema do LMI).
Movimentação de fora da cabine da grua	Controle do veículo fora da cabine da grua, permite mover a máquina quando montada, possível mesmo com carga.
Motor auxiliar independente de aquecimento da grua 5	Sistema auxiliar de aquecimento do diesel independente do motor com 5 kW de potência térmica; Com timer e partida remota; Alternável entre bloco do motor e cabine do veículo.
Ar condicionado da grua 7	Ar condicionado para cabine da grua com 7 kW de potência de refrigeração.

Extensões

HAV19	10 m / 19 m; Braço extensor com dupla articulação, ajuste manual 20° / 40°; Cabeça de 1 roldana; Incl. armazenagem de transporte; Inclui HAV10; Operação com HA ou VA.
HAV27	27 m; Extensão variável com jib articulada, ajuste manual 20° / 40°; Cabeça de 1 roldana; Incl. armazenagem de transporte; Inclui HAV19.
HAV-HY	Inclinação angular hidráulica e contínua de 0 a 40°, em lugar da inclinação manual; Para HAV10 e HAV19 e HAV27.
MSF2	1,5 m; Braço extensor fixo, 2 polias para capacidade máx. 26,6 t; Incl. armazenagem de transporte na cabeça da lança.
R1	Roldana superior articulada; Incl. armazenagem de transporte; Para operação em lance único com altura de gancho elevada.

Diversos

Embalagem para refinaria 2M	Dispositivo de parada de emergência do motor, para o carro e a grua.
Preparação da zorra 4P	Braçadeiras de apoio em 4 pontos permitem o posicionamento individual da zorra; Incl. roda livre para a engrenagem do giro unidade da engrenagem de giro e pistão elevatório e engates rápidos para os sistemas de ar e eletricidade do freio; Zorra e adaptador não incluídos.
Moitão 100-7-18-D	100-7-18-D (750 kg); Moitão com gancho chifre-de-carneiro; branco com faixas de sinalização vermelhas.
Moitão 80-5-18-D	80-5-18-D (650 kg); Moitão com gancho chifre-de-carneiro; branco com faixas de sinalização vermelhas.
Moitão 80-5-18-E	80-5-18-E (650 kg); Moitão com gancho simples; branco com faixas de sinalização vermelhas.
Moitão 50-3-18-D	50-3-18-D (550 kg); Moitão com gancho chifre-de-carneiro; branco com faixas de sinalização vermelhas.
Moitão 50-3-18-E	50-3-18-E (550 kg); Moitão com gancho simples; branco com faixas de sinalização vermelhas.
Moitão 20-1-18-E	20-1-18-E (300 kg); Moitão com gancho simples; branco com faixas de sinalização vermelhas.
Gancho 8-0V-18-E	8-0V-18-E (170 kg); Gancho simples com tornel vertical; vermelho.

Базовое оборудование

Автомобильное шасси

Двигатель 340-4	MTU; Выходная мощность 340 кВт (462 л.с.) при 1700 об/мин, вращающий момент 2200 Нм при 1300 об/мин, сертификация по EURO MOT 4, TIER 4, CARB; Выпускная система из нержавеющей стали с сертифицированным искрогасителем.
Топливный бак 400	400 л.; Топливо: Дизельное.
Коробка передач AS12INT	ZF AS-Tronic; Автоматическая коробка передач со встроенным гидравлическим тормозом-замедлителем 12 передних и 2 задних скорости; 2-ступенчатая раздаточная коробка с включаемой передачей для движения по бездорожью и включаемой продольной блокировкой дифференциала.
Оси 8 x 6 x 8	8 x 6 x 8; 4 моста, мосты 1, 2 и 4 ведущие и оборудованы включаемой поперечной блокировкой дифференциала; Все оси рулящие.
Подвеска	Гидропневматическая подвеска с компенсаторами нагрузки на ось; с гидравлической блокировкой; по выбору – ручная или автоматическая регулировка высоты подвески.
Рулевое управление	Двухконтурная система рулевого управления с гидроусилителем и насосом аварийного торможения; Активные задние рулящие оси (оси 3 и 4) с 6 программами руления.
Тормоза	Пневматическая двухконтурная система рабочих тормозов с ABS, действующая на все колеса; Дисковые тормоза; Дополнительный тормоз-замедлитель на выпускной системе двигателя и воздушный отсекающий клапан на выпуске; Подпружиненный стояночный тормоз.
Колеса 38595 170F	385/95R25 170F (14.00R25); Стальные обода 9,50-25/1,7" CR.
Кабина шасси 2550	Тип 2,55 м; Сиденье водителя с регулировкой положения, подогревом, подлокотниками и пневматической подвеской; С регулировкой высоты и наклона рулевого колеса; Стеклоподъемники дверей; Тонированное стекло; кондиционер и радиоподготовка; 2 встроенных вращающихся проблесковых маячка; отсеки для вещей и инструмента.
Обогрев от двигателя 12	Водяной обогреватель с мощностью нагрева 12 кВт, работающий от двигателя.
Фары шасси	Ближний свет, дальний свет, дневные ходовые огни.
Круиз-контроль	Автоматическое управление скоростью, включая автоматическое управление тормозами.
Система электронного отключения двигателя	Предотвращает несанкционированное передвижение шасси крана; Включая 2 электронных ключа и 4 ключа зажигания.
Разное	Подъемные трапы; Вентиль подкачки шин от пневмосистемы.

Кран

Телескопическая стрела HA50	11,9 м - 50,0 м; Одноцилиндровая система телескопирования, автоматическое управление телескопированием стрелы на выбор; Оснастка для всего оборудования и удлинителей; 5 шкивов, встроенных в вершину стрелы, максимальной грузоподъемностью 64,5 т.
Противовес EG21	на 20,2 т, 5 элементов; система автоматической установки; увеличение веса до 25,2 т; увеличиваемый до максимально 20,2 т, может перевозиться на борту крана стандартной комплектации; 4,5 т, устанавливается в задней части крана.
Опоры	H-образная конструкция с опорой на 4 точки; вертикальное и горизонтальное перемещение полностью за счет гидравлики; по выбору – ручная или автоматическая регулировка высоты с обеих сторон шасси крана; 4 основания опоры.
Подушки опоры 028	4 подушки опоры $A = 0,28 \text{ м}^2$, в транспортном положении закрепляются сверху цилиндра вертикального перемещения.
Изменение вылета стрелы	Один цилиндр изменения вылета стрелы с клапаном автоматического торможения опускания.
Поворотный механизм Н1	Один редуктор поворота с подпружиненным многодисковым тормозом.
Только двигатель 129-4	Механизм подъема с подпружиненным многодисковым тормозом; резольвер.
Топливный бак 200	MTU; Выходная мощность 129 кВт (175 л.с.) при 2200 об/мин, вращающий момент 750 Нм при 1200 об/мин, сертификация по EURO MOT 4, TIER 4, CARB; Выпускная система изготовлена полностью из нержавеющей стали, вкл. искрогаситель.
Привод	200 л.; Топливо: Дизельное.
Система управления	Гидравлическая система с электрическим управлением; Радиатор охлаждения гидравлического масла.
Дополнительные устройства	Позволяет одновременно 4 рабочих движения; электронная система управления, использующая 2 двухосевых джойстика.
Ограничитель рабочего диапазона	ИС-1, включающая встроенный индикатор момента нагрузки, согласно EN13000; цветной дисплей; индикация текущего рабочего положения, графиков нагрузки, индикатора неисправностей; световые сигнализаторы нагрузки LMI (ограничителя момента); регистратор данных рабочих параметров крана.
Кабина крана 0875	Отображение и возможность программирования пределов рабочего диапазона интегральной схемой ИС-1.
Обогрев от двигателя 12	Тип 0,875 м; диапазон угла наклона 20°; обогрев сидений; складывающееся наружу переднее окно; выдвигаемая боковая и складная передняя платформы; оградительные поручни; небьющееся тонированное стекло; опускаемый противосолнечный козырек и светозащитные шторы; кондиционер и радиоподготовка.
Разное	Водяной обогреватель с мощностью нагрева 12 кВт, работающий от двигателя.
Освещение	1 x регулируемый для подсветки рабочей зоны перед кабиной, 4 x для подсветки опор.
Вращающиеся проблесковые маячки 2	2 встроенных на кабине крана, 2 съемных на хвостовой части крана.
Маркировка контура в целях безопасности	Непрерывные светоотражающие полосы по бокам автомобильного шасси и сзади.
Лестница-стремянка	Отдельная лестница-стремянка для сборочных работ; включая укладку для транспортировки.

Опции

Автомобильное шасси

Оси 8 x 8 x 8	8 x 8 x 8; Все 4 моста рулящие с постоянно включенным полным приводом и оборудованы включаемой поперечной блокировкой дифференциала.
Противовес «b» для транспортировки укладывается на заднюю часть поверхности шасси крана	Несущая рама для укладки противовеса «b» весом до 2,9 т на задней части поверхности шасси крана; Необходима для перевозки на шасси противовесов 9,0 т.
Колеса 44595 174F	445/95R25 174F (16.00R25); Стальные обода 11,00-25/1,7" CR.
Колеса 52580 179E	525/80R25 179E (20.50R25); Стальные обода 17,00-25/1,7" CR; Включая расширение шасси до 2,75 м.
Дополнительный обогреватель, независимый от двигателя шасси 10	Дополнительный, независимый от двигателя обогреватель на дизельном топливе с мощностью нагрева 10 кВт; с таймером; переключается между блоком двигателя и кабиной шасси.
Кондиционер шасси 7	Кондиционер кабины шасси крана с мощностью охлаждения 7 кВт.

Кран

Телескопическая стрела HA60	12,0 м - 59,4 м; Одноцилиндровая система телескопирования, автоматический режим телескопирования; Оснастка для всего оборудования и удлинителей; 5 шкивов, встроенных в вершину стрелы, максимальной грузоподъемностью 64,5 т.
Панель дистанционного управления RK S1V	Полнофункциональное дистанционное управление сборкой и работой крана с помощью радиопульта.
H2X	Навесное оборудование для подъема тяжеловесов, стадия 1 с 2 шкивами; не/съёмное; для головки стрелы максимум на 7 шкивов; макс. грузоподъемностью 80,0 т.
Противовес NEG21	2-й подъем; подпружиненный многодисковый тормоз; резольвер; самосборка; включает быстроразъемные соединения и укладку в транспортное положение; позволяет работу с 2 крюками со всеми удлинителями. Вариант для стран с особыми правилами дорожного движения; позволяет саморазборку, общий вес <40 т, с нагрузкой на мост <12 т, противовесы 6 шт. общим весом 20,7 т; система автоматической самосборки с возможностью увеличения веса собираемых компонентов до 25,4 т; в каждом случае обязательна техническая проверка на соответствие правилам.
Дополнительный противовес EG	5,0 т, 2 элемента; Максимум 25,2 т, с 7 элементами; Только в комплекте с противовесом EG21.
Дополнительный противовес NEG	4,7 т, 1 штука; Максимум 25,4 т, с 7 элементами; Только в комплекте с противовесом NEG21.
Быстроразъемное соединение HA2	Гидравлическая система извлечения болтов и гидравлический и электрический приводы быстроразъемных соединений для быстрой сборки (разборки). Включая укладку цилиндра изменения вылета стрелы в положение для транспортировки.
Индикатор нагрузки выносных опор	Отображение на индикаторе момента нагрузки в кабине.
Контроль положения несущего основания, создаваемого опорами	Контроль положения каждой балки выносной опоры для визуального сравнения с запрограммированным положением несущего основания, создаваемого опорами; Отображается на экране индикатора ограничителя момента нагрузки в кабине крана (Внимание! Автоматическое подключение к системе LMI (индикатора ограничителя момента нагрузки) отсутствует!
Управление движением из кабины крана	Управление движением из кабины крана позволяет перемещение машины с собранным краном, возможно даже под нагрузкой.
Дополнительный обогреватель, не связанный с двигателем, кран 5	Дополнительный, независимый от двигателя обогреватель на дизельном топливе с мощностью нагрева 5 кВт; С таймером и дистанционным запуском; переключается между блоком двигателя и кабиной шасси.
Кондиционер крана 7	Кондиционер для кабины крана с мощностью охлаждения 7 кВт.

Удлинители

HAV19	10 м / 19 м; Складываемая вдвое откидная дополнительная стрела с ручной установкой угла сдвига 20°/40°; головка на 1 шкив; вкл. укладку в транспортировочное положение; включает HAV10; для применения с HA и VA.
HAV27	27 м; Удлинитель стрелы переменной длины с откидным гуськом с ручной установкой угла сдвига 20°/40°; головка на 1 шкив; вкл. укладку в транспортировочное положение; включает HAV19.
HAV-HY	Гидравлическая система бесшаговой установки угла сдвига, вместо ручной установки; Для HAV10, соответственно HAV19 и HAV 27.
MSF2	1,5 м; Стационарная сборная дополнительная стрела, 2-шкивная, макс. грузоподъемность 26,6 т; включая укладку для транспортировки на вершине стрелы.
R1	Отводной шкив; включая укладку для транспортировки; для одиночной запасовки с поднятым крюком.

Разное

Подготовка грузовой тележки 4PV	Кронштейны с 4 точками опоры позволяют независимое расположение тележки; вкл. колесо свободного хода поворотного механизма и цилиндр изменения вылета стрелы, быстроразъемные соединения тормозной системы и электропроводки; тележка и соединительный разъем тележки в комплект не входят.
Комплектация для работы на площадках нефтеперегонных заводов 2M	Устройство аварийного останова двигателя для шасси и крана с отсечной воздушной заслонкой.
Крюкблок 100-7-18-D	100-7-18-D (750 кг); крюкблок с храповым крюком; белый с красными сигнальными полосами.
Крюкблок 80-5-18-D	80-5-18-D (650 кг); крюкблок с храповым крюком; белый с красными сигнальными полосами.
Крюкблок 80-5-18-E	80-5-18-E (650 кг); крюкблок с одним храповым крюком; белый с красными сигнальными полосами.
Крюкблок 50-3-18-D	50-3-18-D (550 кг); крюкблок с храповым крюком; белый с красными сигнальными полосами.
Крюкблок 50-3-18-E	50-3-18-E (550 кг); крюкблок с одним храповым крюком; белый с красными сигнальными полосами.
Крюкблок 20-1-18-E	20-1-18-E (300 кг); крюкблок с одним храповым крюком; белый с красными сигнальными полосами.
Крюк 8-0V-18-E	8-0V-18-E (170 кг); Одиночный крюк с вертикальным шарнирным соединением красный.

Anmerkungen zu den Tragfähigkeiten · Conditions d'utilisation · Annotazioni sulle portate · Condiciones de utilización · Notas sobre capacidade de içamento · Примечания по грузоподъемности

The telescopic loads stated in the capacity chart are valid under the following conditions:

- The sliding areas of the telescopes must be lubricated well.
- The surroundings temperature has to be normal (considerable reductions must be expected below 0 °C).
- The radius in the chart is given for the end length of the telescopic sequence.
- The capacities are valid for extending and retracting the telescopic section.
- The telescopic loads are only valid for moving the last section of the sequence. The curve for e. g. 0-0-45-90-90 % is only valid for telescoping from 0-0-0-90-90 % to 0-0-45-90-90 % and back, but not for 0-0-0-0-0 % to 0-0-45-90-90 %!
- The telescopic loads are based on the telescoping ability of the boom. The loads to be telescoped must never exceed the loads in the load chart as tipping of the crane may occur.
- The most advantageous individual telescoping sequence is shown. Other telescoping sequences for the same boom length will result in lower lifting capacities for telescoping. Refer to the machine's documentation for these lifting capacity values.

Für die in der Tabelle aufgeführten Teleskopierlasten gelten folgende Bedingungen:

- Die Gleitflächen der Teleskope sind gut geschmiert.
- Es herrschen normale Umgebungstemperaturen (unter 0 °C ist mit starken Reduzierungen zu rechnen).
- Der auf den Tabellen angegebene Radius ist auf die Endlänge der jeweiligen Teleskopierfolge bezogen.
- Die Tragfähigkeiten gelten für das Aus- und Einteleskopieren.
- Die teleskopierbaren Tragfähigkeiten gelten nur für das Bewegen des letzten Kastens in der Teleskopierfolge. Die Kurve für z. B. 0-0-45-90-90 % gilt also nur für das Teleskopieren von 0-0-0-90-90 % nach 0-0-45-90-90 % und zurück, nicht jedoch für 0-0-0-0-0 % nach 0-0-45-90-90 %!
- Die teleskopierbaren Lasten richten sich ausschließlich nach der Teleskopierfähigkeit des Auslegers. Die Lasten, die teleskopiert werden, dürfen die in der Traglasttabelle angegebenen Werte nie überschreiten, da der Kran sonst kippen könnte.
- Dargestellt ist die jeweils günstigste Teleskopierfolge. Andere Teleskopierfolgen / mit gleicher Auslegerlänge haben geringere teleskopierbare Tragfähigkeiten, diese sind der Dokumentation des Gerätes zu entnehmen.

Les conditions suivantes s'appliquent aux charges télescopables présentées dans le tableau :

- Bonne lubrification des surfaces de glissement du télescope.
- Températures extérieures normales (fortes réductions des capacités de charge en cas de température inférieure à 0 °C).
- Le rayon indiqué sur les tableaux se réfère à la longueur finale de la séquence de télescopage correspondante.
- Les capacités de charge s'appliquent au déploiement et à la rétraction de la flèche télescopique.
- Les charges télescopables s'appliquent uniquement au mouvement de la dernière section de la séquence de télescopage. Une courbe de 0-0-45-90-90 % s'applique ainsi uniquement au télescopage de 0-0-0-90-90 % à 0-0-45-90-90 % et au retour dans la position initiale, et non de 0-0-0-0-0 % à 0-0-45-90-90 % !
- Les charges télescopiques sont fonction de la capacité de télescopage de la flèche. Les charges à télescoper ne doivent jamais dépasser les charges indiquées sur le graphique de charge, un basculement de la grue risquant alors de se produire.
- La séquence de télescopage individuelle la plus avantageuse est indiquée. Les autres séquences de télescopage pour une longueur de flèche identique disposent de capacités de charge télescopables moins élevées. Ces dernières figurent dans la documentation relative à l'appareil.

I carichi indicati in tabella si riferiscono alle seguenti condizioni:

- Area di sfilo correttamente lubrificata.
- Temperatura ambiente compresa nell'intervallo normale (con temperature inferiori a 0 °C occorre considerare una notevole riduzione delle capacità).
- Lo sbraccio indicato in tabella si riferisce alla lunghezza finale della rispettiva sequenza di sfilo.
- Le portate si applicano sia per lo sfilo che per il rientro delle sezioni.
- Le portate indicate si riferiscono solo al movimento dell'ultima sezione della sequenza di sfilo. La curva per, ad esempio, 0-0-45-90-90 % si applica solo per lo sfilo da 0-0-0-90-90 % a 0-0-45-90-90 % e per il corrispondente rientro, ma non per lo sfilo da 0-0-0-0-0 % a 0-0-45-90-90 %!
- I carichi sollevabili con il braccio telescopico sono basati sulla capacità di sfilo del braccio. I carichi sollevabili col braccio sfilato non devono superare i valori riportati nella tabella dei carichi, per evitare il rischio di ribaltamento della gru.
- La figura mostra la configurazione più vantaggiosa. L'utilizzo di altre sequenze di sfilo con la stessa lunghezza del braccio determina portate inferiori, rilevabili dalla documentazione in dotazione con la macchina.

Anmerkungen zu den Tragfähigkeiten · Conditions d'utilisation · Annotazioni sulle portate · Condiciones de utilización · Notas sobre capacidade de içamento · Примечания по грузоподъемности

Las cargas con telescopaje referidas en la tabla son aplicables bajo las condiciones siguientes:

- Las superficies de deslizamiento de los dispositivos telescópicos han de encontrarse bien lubricadas.
- La temperatura ambiente estará dentro del margen „normal“ (por debajo de 0 °C ha de contarse con considerables reducciones en las capacidades de carga).
- El radio indicado en la tabla se aplica a la longitud extendida total de la respectiva secuencia de telescopaje.
- Las capacidades de carga se aplican al despliegue y a la retracción de la flecha telescópica.
- Las capacidades de carga telescópica se aplican únicamente al movimiento del último segmento de la secuencia de telescopaje. Por ejemplo, la curva para 0-0-45-90-90 % se aplica únicamente al telescopaje desde 0-0-0-90-90 % hasta 0-0-45-90-90 % y viceversa, pero no desde 0-0-0-0-0 % hasta 0-0-45-90-90 %!
- Las cargas telescópicas están basadas en la capacidad de telescopaje de la flecha. Las cargas que se desee telescopar no deberán exceder nunca las indicadas en la tabla de cargas, ya que la grúa podría volcar.
- La secuencia de telescopaje que aparece representada es la más ventajosa para cada caso. Otras secuencias de telescopaje con la misma longitud de flecha darán como resultado menores capacidades de carga telescópica. Dichos valores han de consultarse en la documentación de la máquina.

As cargas telescópicas indicadas na tabela de capacidades são válidas sob as seguintes condições:

- A área deslizante dos telescópios tem de ficar bem lubrificadas.
- A temperatura nas redondezas tem de estar normal (devem-se esperar reduções consideráveis abaixo de 0 °C).
- O raio na tabela é dado para o comprimento final da sequência telescópica.
- As capacidades são válidas para estender e retrain a seção telescópica.
- As cargas telescópicas só são válidas para mover a última seção da sequência. A curva para, p.ex., 0-0-45-90-90 % só é válida para telescopagem de 0-0-0-90-90 % a 0-0-45-90-90 % e de volta, mas não para 0-0-0-0-0 % a 0-0-45-90-90 %!
- As cargas telescópicas baseiam-se na capacidade de telescopagem da lança. As cargas a serem telescopadas não podem nunca ultrapassar aquelas da tabela de carga, pois isto pode provocar o tombamento da grua.
- Mostra-se abaixo a sequência de telescopagem individual mais vantajosa. Outras sequências para o mesmo comprimento de lança resultarão em capacidades menores de içamento. Consulte na documentação da máquina esses valores de capacidade de içamento.

Нагрузки в режиме выдвижения/втягивания стрелы, указанные в таблице номинальных нагрузок, действительны только при следующих условиях:

- выдвижные секции стрелы должны быть хорошо смазаны;
- температура воздуха должна быть нормальной (при температуре ниже 0 °C следует ожидать значительного сокращения);
- радиус, указанный в таблице, дается для конечной длины выдвижения/втягивания стрелы;
- нагрузки действительны применительно к выдвигаемой или втягиваемой секции стрелы;
- нагрузки в режиме выдвижения/втягивания действительны для движении только последней секции цикла; указанная кривая, например, 0-0-45-90-90 % действительна только для движения от 0-0-0-90-90 % к 0-0-45-90-90 % и назад, но не для движения от 0-0-0-0-0 % к 0-0-45-90-90 %!
- нагрузки в режиме выдвижения/втягивания стрелы, указанные в таблице, действительны при нормальной работе механизма выдвижения/втягивания стрелы; Указанные в таблице нагрузки ни при каких обстоятельствах нельзя превышать, поскольку это может вызвать опрокидывание крана.
- Указаны оптимальные циклы последовательности выдвижения/втягивания. Использование других последовательностей при той же конечной длине стрелы ведет к снижению грузоподъемности стрелы в режиме выдвижения/втягивания. Данные о грузоподъемности даются в документации к машине.

Anmerkungen zu den Tragfähigkeiten · Conditions d'utilisation · Annotazioni sulle portate · Condiciones de utilización · Notas sobre capacidade de içamento · Примечания по грузоподъемности

Ratings are in compliance with ISO 4305.

Weight of hook blocks and slings is part of the load, and is to be deducted from the capacity ratings.

Consult operation manual for further details.

Note: Data published herein is intended as a guide only and shall not be construed to warrant applicability for lifting purposes. Crane operation is subject to the computer charts and operation manual both supplied with the crane.

Tragfähigkeiten entsprechen ISO 4305.

Das Gewicht der Unterflaschen, sowie die Lastaufnahmemittel, sind Bestandteile der Last und sind von den Tragfähigkeitsangaben abzuziehen.

Weitere Angaben in der Bedienungsanleitung des Kranes.

Anmerkung: Die Daten dieser Broschüre dienen nur zur allgemeinen Information; für ihre Richtigkeit übernehmen wir keine Haftung. Der Betrieb des Kranes ist nur mit den Original-Tragfähigkeitstabellen und mit der Bedienungsanleitung zulässig, die mit dem Kran mitgeliefert werden.

Le tableau de charges est conforme à la norme ISO 4305.

Les poids du crochet-moufle et de tous les accessoires d'élingage font partie de la charge et sont à déduire des charges indiquées.

Pour plus de détails consulter la notice d'utilisation de la grue.

Nota: Les renseignements ci-inclus sont donnés à titre indicatif et ne représentent aucune garantie d'utilisation pour les opérations de levage. La mise en service de la grue n'est autorisée qu'à condition que les tableaux de charges ainsi que le manuel de service, tels que fournis avec la grue, soient observés.

Le portate sono conformi alla norma ISO 4305.

Il peso del bozzello e delle funi d'attacco fanno parte del carico e sono quindi da detrarre dai valori di tabella.

Per ulteriori dettagli sulla velocità vento, consultare il manuale di istruzione della gru.

Nota: I dati riportati su tale prospetto sono solo a titolo indicativo e pertanto non impegnativi. L'impiego della gru è ammesso solo rispettando le tabelle originali ed il manuale di uso fornito assieme alla gru.

Las capacidades de carga están sujetas a las normas ISO 4305.

El peso de los ganchos y eslingas son parte de la carga y serán deducidos de las capacidades brutas.

Consultar los manuales de operación para ampliar información.

Observación: Los datos publicados son solamente orientativos y no se deben interpretar como garantía de aplicación para determinadas operaciones de elevación. La manipulación de la grúa está sujeta a las cargas programadas en el ordenador y en el manual de operaciones, ambos suministrados con la grúa.

Valores nominais de acordo com a ISO 4305.

O peso dos moitões e eslingas faz parte da carga e tem de ser subtraído das capacidades nominais.

Consultar manual de operação para outros detalhes.

Nota: Os dados publicados aqui destinam-se a simples orientação e não devem ser interpretados como garantia de aplicabilidade para fins de içamento.

A operação da grua depende de tabelas de computador e do manual de operação, ambos fornecidos com a máquina.

Номинальные значения соответствуют ISO 4305.

Вес крюкоблока и строп является частью груза и должен вычитаться из номинальных значений грузоподъемности.

Подробности см. в руководстве по эксплуатации.

Примечание. Публикуемые в настоящем издании данные приводятся только для справки и не должны использоваться при расчете нагрузки. При эксплуатации крана должны применяться компьютерные таблицы и руководство по эксплуатации, входящие в комплект поставки крана.

NOTES

AC 100/4(L)

Notizen · Notes · Nota · Notas · Notas ·
пометы, комментарии, примечания

A large rectangular area with horizontal lines, intended for writing notes. The lines are evenly spaced and cover the majority of the page's width and height.

Effective Date: February 2015.

Product specifications and prices are subject to change without notice or obligation. The photographs and/or drawings in this document are for illustrative purposes only. Refer to the appropriate Operator's Manual for instructions on the proper use of this equipment. Failure to follow the appropriate Operator's Manual when using our equipment or to otherwise act irresponsibly may result in serious injury or death. The only warranty applicable to our equipment is the standard written warranty applicable to the particular product and sale and Terex makes no other warranty, express or implied. Products and services listed may be trademarks, service marks or trade-names of Terex Corporation and/or its subsidiaries in the USA and other countries. All rights are reserved. Terex® is a registered trademark of Terex Corporation in the USA and many other countries.

Gültig ab: Februar 2015.

Produktbeschreibungen und Preise können jederzeit und ohne Verpflichtung zur Ankündigung geändert werden. Die in diesem Dokument enthaltenen Fotos und/oder Zeichnungen dienen rein anschaulichen Zwecken. Anweisungen zur ordnungsgemäßen Verwendung dieser Ausrüstung entnehmen Sie bitte dem zugehörigen Betriebshandbuch. Nichtbefolgung des Betriebshandbuchs bei der Verwendung unserer Produkte oder anderweitig fahrlässiges Verhalten kann zu schwerwiegenden Verletzungen oder Tod führen. Für dieses Produkt wird ausschließlich die entsprechende, schriftlich niedergelegte Standardgarantie gewährt. Terex leistet keinerlei darüber hinaus gehende Garantie, weder ausdrücklich noch stillschweigend. Die Bezeichnungen der aufgeführten Produkte und Leistungen sind gegebenenfalls Marken, Servicemarken oder Handelsnamen der Terex Corporation und/oder ihrer Tochtergesellschaften in den USA und anderen Ländern. Alle Rechte vorbehalten. „TEREX“ ist eine eingetragene Marke der Terex Corporation in den USA und vielen anderen Ländern.

Date d'effet : Février 2015.

Les spécifications et prix des produits sont sujets à modification sans avis ou obligation. Les photographies et/ou dessins contenus dans ce documents sont uniquement pour illustration. Veuillez vous référer à la notice d'utilisation appropriée pour les instructions quant à l'utilisation correcte de cet équipement. Tout manquement au suivi de la notice d'utilisation appropriée lors de l'utilisation de notre équipement ou tout acte autrement irresponsable peut résulter en blessure corporelle sérieuse ou mortelle. La seule garantie applicable à notre équipement est la garantie standard écrite applicable à un produit et à une vente spécifique. Terex n'offre aucune autre garantie, expresse ou implicite. Les produits et services proposés peuvent être des marques de fabrique, des marques de service ou des appellations commerciales de Terex Corporation et/ou ses filiales aux Etats Unis et dans les autres pays, et tous les droits sont réservés. «TEREX» est une marque déposée de Terex Corporation aux Etats Unis et dans de nombreux autres pays.

Data di inizio validità: Febbraio 2015.

Ci riserviamo il diritto di modificare le specifiche e i prezzi dei prodotti in ogni momento e senza preavviso. Le fotografie e/o i disegni contenuti in questo documento sono destinati unicamente a scopi illustrativi. Consultare le istruzioni sull'uso corretto di questo macchinario, contenute nell'opportuno Manuale dell'operatore. L'inottemperanza delle istruzioni contenute nel Manuale dell'operatore del macchinario e altri comportamenti irresponsabili possono provocare gravi lesioni, anche mortali. L'unica garanzia applicabile ai nostri macchinari è la garanzia scritta standard applicabile al particolare prodotto e alla particolare vendita; Terex è esonerata dal fornire qualsiasi altra garanzia, esplicita o implicita. I prodotti e servizi elencati possono essere dei marchi di fabbrica, marchi di servizio o nomi commerciali di TEREX Corporation e/o società affiliate negli Stati Uniti d'America e altre nazioni e tutti i diritti sono riservati. „TEREX“ è un marchio registrato di Terex Corporation negli USA e molti altri Paesi.

Fecha efectiva: Febrero 2015.

Los precios y las especificaciones de productos pueden sufrir cambios sin aviso previo u obligación. Las fotografías o dibujos de este documento tienen un fin meramente ilustrativo. Consulte el manual de instrucciones del operador correspondiente para más información sobre el uso correcto de este equipo. El hecho de no respetar el manual del operador correspondiente al utilizar el equipo o actuar de forma irresponsable puede suponer lesiones graves o fatales. La única garantía aplicable a nuestro equipo es la garantía escrita estándar correspondiente a cada producto y venta, y TEREX no amplía dicha garantía de forma expresa o implícita. Los productos y servicios mencionados pueden ser marcas registradas, marcas de servicio o nombres de marca de TEREX Corporation o de sus filiales en Estados Unidos de América y otros países, y se reservan todos los derechos. „TEREX“ es una marca comercial registrada de Terex Corporation en Estados Unidos de América y muchos otros países.

Data de vigência: Fevereiro 2015.

Especificações e preços dos produtos sujeitos a alteração sem aviso prévio ou obrigações. As fotografias e/ou desenhos deste documento servem apenas para fins ilustrativos. Consulte o respectivo Manual de Instruções para instruções sobre o uso correto deste equipamento. A falta de atenção ao respectivo Manual do Operador no uso de nosso equipamento ou a operação da máquina em condições impróprias pode resultar em lesão grave ou morte. A única garantia aplicável aos nossos equipamentos é a garantia padrão por escrito, aplicável ao produto específico e à sua venda, sem que nenhuma outra, expressa ou implícita, seja oferecida pela Terex. Os produtos e serviços listados podem ser marcas comerciais, marcas de serviço ou nomes-fantasia da Terex Corporation e/ou suas subsidiárias nos EUA e em outros países. Todos os direitos reservados. Terex® é marca registrada da Terex Corporation nos EUA e muitos outros países.

Вступает в силу: Февраль 2015 г.

Технические характеристики и цены могут изменяться без предварительного уведомления и без каких-либо обязательств для производителя. Фотографии и (или) чертежи, использованные в документе, приведены исключительно в качестве иллюстраций. Инструкции по правилам эксплуатации даются в соответствующих руководствах для операторов данного оборудования. Невыполнение рекомендаций руководства по эксплуатации нашего оборудования или другие безответственные действия могут повлечь серьезные травмы или смерть. Единственной гарантией, действующей в отношении нашего оборудования, является стандартная форма письменной гарантии на данный тип оборудования и на условия его продажи.

Copyright Terex Cranes 2015

Terex Cranes, Global Marketing, Dinglerstraße 24, 66482 Zweibrücken, Germany
Tel. +49 (0) 6332 830, Email: info.cranes@terex.com, www.terexcranes.com



www.terex.com/cranes

Brochure Reference: TC-DS-M-E/F/G/I/S/P/R-AC100/4(L) Tier 4-02/15



WORKS FOR YOU.™